

Outstanding Visibility with Reliable Performance

XF Series

There is increasing demand for outdoor signage for delivering information and advertisement. With high-brightness and reliable performance, the open frame XF Series is able to achieve these goals effectively in any location.

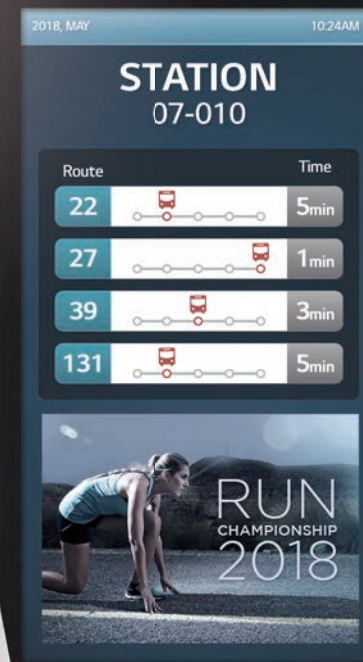

2018, MAY 10:24AM

STATION 07-010

Route	Time
22	5min
27	1min
39	3min
131	5min

 RUN CHAMPIONSHIP 2018



Outstanding Visibility with Reliable Performance

XF Series

Outstanding Visibility

High Brightness

With a great brightness of 3,000 cd/m², XF series clearly deliver contents and attract public attention, which is the ultimate display for outdoor visibility.



Visible with Polarized Sunglasses

QWP* enables clear visibility even when the viewer is wearing polarized sunglasses.



* Quarter Wave Plate

Outstanding Visibility with Reliable Performance

XF Series

Outstanding Visibility

No Blackening

Even under direct sunlight exposure, the open frame XF series remain free of blackening defects under 110°C and provide superior quality for outdoor usage.



Conventional

XF series

Smart Brightness Control

The screen brightness is automatically adjusted depending on the ambient light. The brightness is increased in light for better visibility, while it is decreased in darkness for efficient power management.



Auto Brightness

Outstanding Visibility with Reliable Performance

XF Series

Product Reliability

High Operating Temperature

Its high reliability under high operating temperatures reduces additional costs for air conditioning system.



Conformal Coating

The product can be often unavoidably exposed to dust and water during maintenance. Conformal coating on every major circuit board eliminates such troubles by protecting it against dust, iron powder, humidity, etc.



Outstanding Visibility with Reliable Performance

XF Series

Easy Maintenance

High-Performance with webOS Smart Platform

Quad Core SoC* can execute several tasks at the same time without a separate media player. In addition, webOS 3.0 platform enhances user convenience with intuitive UI and simple app development tools.

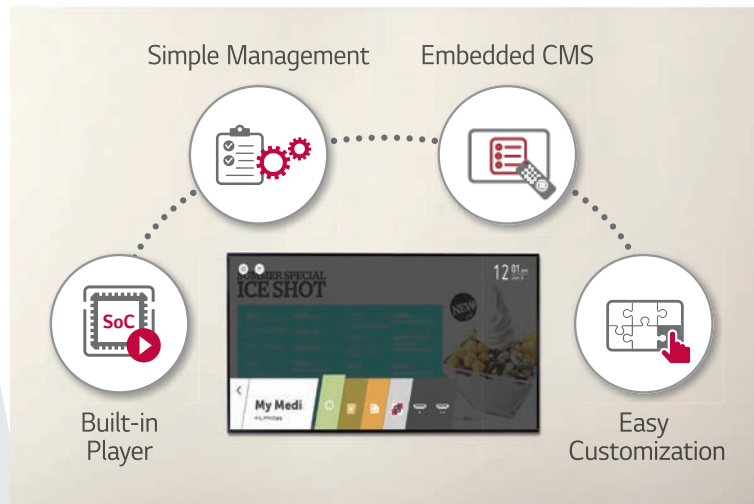

Slim Design

Thanks to its thin depth, the XF series takes up less space and leads to ease of installation for various applications.



Dimension

75"

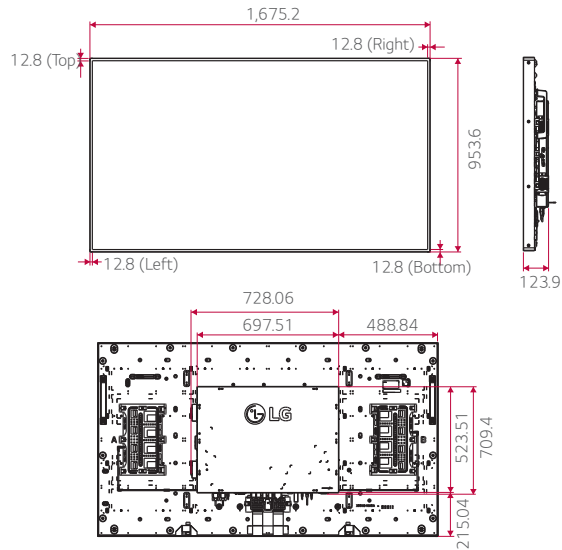

55"

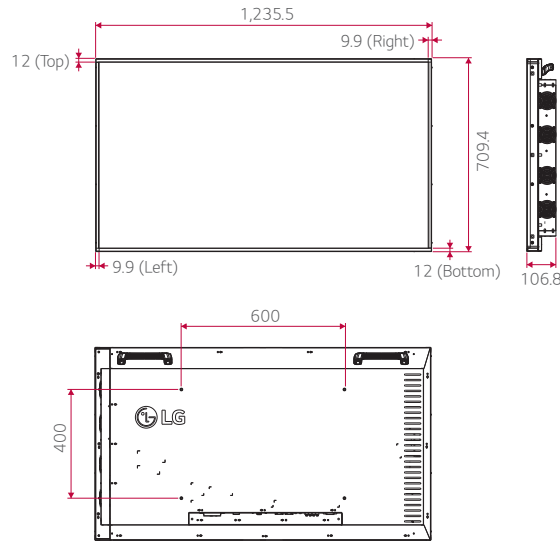

49"

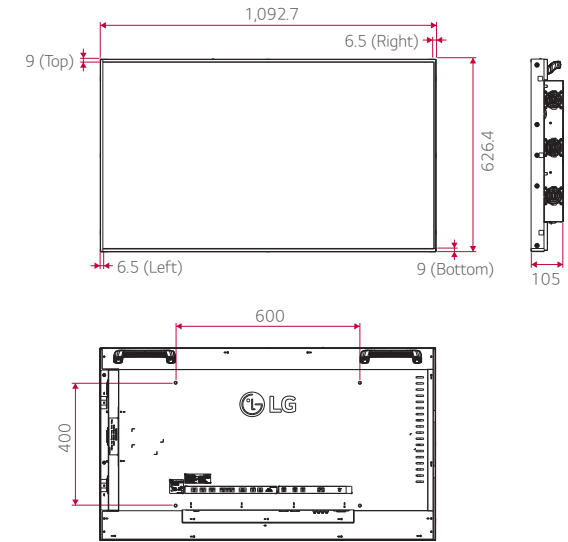

Connectivity

75"

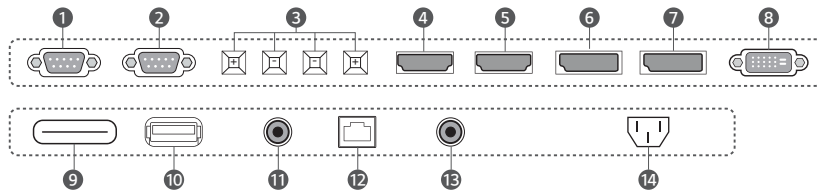

- 1 RS 232C IN
- 2 RS 232C OUT
- 3 SPEAKER OUT (8 Ω)
- 4 HDMI IN 1
- 5 HDMI IN 2
- 6 DP IN
- 7 DP OUT
- 8 DVI-D IN
- 9 SD CARD
- 10 USB IN
- 11 AUDIO IN (PC)
- 12 LAN
- 13 PIXEL SENSOR
- 14 AC IN

55"/49"

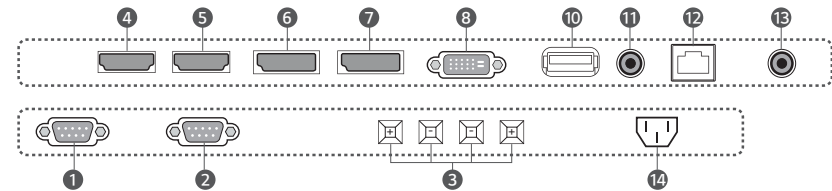

Specifications

		75XF3C	55XF3E	49XF3E
PANEL	Screen Size	75" (74.54" Measured Diagonal)	55" (54.64" Measured Diagonal)	49" (48.50" Measured Diagonal)
	Panel Technology	IPS, M+ (WRGB)	IPS, M+ (WRGB)	M+ (WRGB)
	Aspect Ratio	16 : 9	16 : 9	16 : 9
	Native Resolution	3,840 x 2,160 (UHD)	1,920 x 1,080 (FHD)	1,920 x 1,080 (FHD)
	Brightness	3,000 cd/m ² (Typ.), 2,400 cd/m ² (Min.)	3,000 cd/m ² (Typ.), 2,400 cd/m ² (Min.)	3,000 cd/m ² (Typ.), 2,400 cd/m ² (Min.)
	Contrast Ratio	1,200 : 1	1,000 : 1	1,000 : 1
	Viewing Angle (H x V)	178 x 178	178 x 178	178 x 178
	Surface Treatment	AGLR (Haze 3%), QWP	AGLR (Haze 3%), QWP	AGLR (Haze 3%), QWP
	Lifetime	50,000 Hrs	50,000 Hrs	50,000 Hrs
	Operation Hours	24 Hrs	24 Hrs	24 Hrs
Orientation	Landscape & Portrait	Landscape & Portrait	Landscape & Portrait	
CONNECTIVITY	Input	HDMI (2), DP, DVI-D, Audio, USB, SD Card	HDMI (2), DP, DVI-D, Audio, USB	HDMI (2), DP, DVI-D, Audio, USB
	Output	DP, External Speaker	DP, External Speaker	DP, External Speaker
	External Control	RS232C In/Out, RJ45 In, IR Receiver In, Pixel Sensor In	RS232C In/Out, RJ45 In, IR Receiver In, Pixel Sensor In	RS232C In/Out, RJ45 In, IR Receiver In, Pixel Sensor In
PHYSICAL SPECIFICATION	Bezel Color	Black	Black	Black
	Bezel Width	12.8 mm (Even)	12 mm (T/B), 9.9mm (L/R)	9 mm (T/B), 6.5 mm (L/R)
	Monitor Dimension (W x H x D)	1,675.2 x 953.6 x 123.9 mm	1,235.5 x 709.4 x 106.8 mm	1,092.7 x 626.4 x 105 mm
	Weight (Head)	36.7 kg	26.5 kg	21 kg (TBD)
	Carton Dimensions (W x H x D)	1,816 x 1,106 x 285 mm	1,344 x 236 x 820 mm	1,195 x 196 x 760 mm
	Packed Weight	46.3 kg	32.25 kg	25.7 kg (TBD)
	VESA™ Standard Mount Interface	N/A	600 x 400 mm	600 x 400 mm
SPECIAL FEATURES	Temperature Sensor, Cooling Fan, Auto Brightness Sensor, Energy Saving, Smart Energy Saving, Tile Mode (up to 15 x 15), Natural Mode@Tile Mode, Source Selection, Brightness/Contrast/Backlight, DPM Select, File Play with USB, Internal Memory, Wi-Fi Dongle Ready			
ENVIRONMENT CONDITIONS	Operation Temperature*	0°C to 50°C	0°C to 50°C	0°C to 50°C
	Operation Humidity	10% to 85%	10% to 80%	10% to 80%
POWER	Power Supply	Built-In Power	Built-In Power	Built-In Power
	Power Type	100-240 V~, 50/60 Hz	100-240 V~, 50/60 Hz	100-240 V~, 50/60 Hz
	Power Consumption	660 W / 695 W	250 W / 290 W	240 W (TBD) / 270 W (TBD)
	Smart Energy Saving	320 W	120 W	95 W
STANDARD (CERTIFICATION)	Safety	UL Recognized / CB	UL Recognized / CB	UL Recognized / CB
	EMC	FCC Class "A" / CE / KC	FCC Class "A" / CE / KC	FCC Class "A" / CE / KC / VCCI
SOFTWARE COMPATIBILITY	Content Management Software	SuperSign CMS	SuperSign CMS	SuperSign CMS
	Control and Monitoring Software	SuperSign C	SuperSign Link	SuperSign Link
ACCESSORIES	Basic	Remote Controller (2 Batteries Included), Power Cord, IR Extension Cable/PCB, HDMI Cable, Manual (ESG&EIG), IR Bracket	Remote Controller (2 Batteries Included), Power Cord, IR Extension Cable/PCB, HDMI Cable, Manual (ESG&EIG), IR Bracket	Remote Controller (2 Batteries Included), Power Cord, IR Extension Cable/PCB, HDMI Cable, Manual (ESG&EIG)
	Optional	Wi-Fi Dongle (AN-WF500) * Stand is not available	Wi-Fi Dongle (AN-WF500) * Stand is not available	Wi-Fi Dongle (AN-WF500) * Stand is not available

* Without direct sunlight or with cooling systems in direct sunlight

Download LG Commercial Display Mobile App



Apple App Store



Google Play Store

www.lg.com/b2b

[youtube.com/c/LGCommercialDisplay](https://www.youtube.com/c/LGCommercialDisplay)

<https://www.facebook.com/LGInformationDisplay/>

<https://www.linkedin.com/company-beta/16235211/>

LG may make changes to specifications and product descriptions without notice.

Copyright © 2018 LG Electronics Inc. All rights reserved. "LG Life's Good" is a registered trademark of LG Corp.

The names of products and brands mentioned here may be the trademarks of their respective owners.

