

# GefenPRO®



**1080P**  
PROGRESSIVE

## 32x32 Modular Matrix

GEF-MOD-32432-DVI • GEF-MOD-32432-DVIELR  
GEF-MOD-32432-DVI1FO • GEF-MOD-32432-FM10001FO  
GEF-MOD-32432-DPDVI • GEF-MOD-32432-DPELR  
GEF-MOD-32432-DP1FO

**User Manual**

**[www.gefenpro.com](http://www.gefenpro.com)**



## ASKING FOR ASSISTANCE

---

### Technical Support:

Telephone (818) 772-9100  
(800) 545-6900

Fax (818) 772-9120

### Technical Support Hours:

8:00 AM to 5:00 PM Monday through Friday, Pacific Time  
For 24 / 7 support, see the back of the product for the support number

### Write To:

Gefen, LLC  
c/o Customer Service  
20600 Nordhoff St  
Chatsworth, CA 91311

[www.gefenpro.com](http://www.gefenpro.com)  
[support@gefenpro.com](mailto:support@gefenpro.com)

### Notice

Gefen, LLC reserves the right to make changes in the hardware, packaging and any accompanying documentation without prior written notice.

**32x32 Modular Matrix** is a trademark of Gefen, LLC

All trademarks are the property of their respective companies.

© 2012 Gefen, LLC, All Rights Reserved  
All trademarks are the property of their respective companies

**Rev A1**

# CONTENTS

---

<b>INTRODUCTION</b> .....	<b>1</b>
Features.....	2
Package Includes.....	2
Pre-Configured Options.....	3
Front Panel Layout.....	8
Front Panel Descriptions.....	9
Back Panel Layout.....	10
Back Panel Descriptions.....	11
<b>CONNECTING THE 32x32 MODULAR MATRIX</b> .....	<b>12</b>
Connections.....	12
Wiring Diagram.....	12
DisplayPort package options.....	19
<b>OPERATING THE 32x32 MODULAR MATRIX</b> .....	<b>20</b>
Booting Up / Standby Screen.....	20
Displaying the current Routing State.....	21
Routing Sources.....	22
Locking the Matrix.....	24
Using the Cancel button.....	25
Cycling between Information Screens.....	26
Saving the current Routing State.....	27
Recalling a stored Routing State.....	29
Masking Outputs.....	31
EDID Management.....	33
Saving the Downstream EDID to Local memory.....	33
Saving the Default EDID to Local memory.....	35
<b>RS-232 / IP CONTROL</b> .....	<b>37</b>
RS-232 Interface.....	37
RS-232 Settings.....	37
Configuring the IP Address.....	38
RS-232 / Telnet Commands.....	39
EDID Management.....	39
IP Configuration.....	49
Routing and Masking.....	57
System.....	67
Using the Built-in Web server.....	75
Routing.....	75
Routing.....	75
Preset Names.....	79
I/O Names.....	80
+5V.....	81
Output Masks.....	83

# CONTENTS

---

Status.....	85
In / Out.....	85
System.....	86
Manage EDID.....	87
Assign.....	87
Bank Names.....	89
Upload / Download.....	90
Configuration.....	91
<b>APPENDIX.....</b>	<b>95</b>
Card Removal and Installation.....	95
Firmware Update Procedure.....	98
<b>RACK MOUNT SAFETY INFORMATION.....</b>	<b>102</b>
<b>SPECIFICATIONS.....</b>	<b>103</b>
<b>WARRANTY.....</b>	<b>104</b>
<b>LICENSING.....</b>	<b>105</b>

# IMPORTANT OPERATING NOTES

---

## READ THESE NOTES BEFORE INSTALLING OR OPERATING THE 32X32 MODULAR MATRIX

- There is no internal scaling in the 32x32 Modular Matrix. All of the attached monitors must be able to display the output resolutions of the source devices. For maximum compatibility it is recommended that only one compatible/common resolution be used by all of the source devices.
- Routing features can be accessed using the serial control interface or via Telnet. See page 37 - 74 for more information.
- The 32x32 Modular Matrix has several The Gefen 32x32 Modular Matrix provides several different pre-configured packages to suit the needs of your application. This User Manual covers all available configurations. See page 3 for information on identifying the type of 32x32 Modular Matrix that was purchased.



**IMPORTANT:** If the unit is installed in a closed or multi-rack assembly, do not block the ventilation holes of the enclosure.

# INTRODUCTION

---

Congratulations on your purchase of the 32x32 Modular Matrix. Your complete satisfaction is very important to us.

## **GefenPRO**

In the realm of video distribution, certain features are invaluable in a commercial or broadcast environment. Accommodations such as a built-in power supply and flat black rack-mount enclosures set GefenPRO apart from our traditional products. Complex distribution units allow for professional DVI, 3G-SDI, and HDMI signals to be routed and converted easily and seamlessly, while being backed up by a renowned and dependable technical support team. Gefen invites you to explore the GefenPRO product line and hopes that you find the solution that fits your needs.

## **The Gefen 32x32 Modular Matrix**

The GefenPRO 32x32 Modular Matrix provides an all-in-one professional-grade solution to route up to 32 DVI sources to any 32 DVI displays with resolutions up to 1920 x 1200. The modular design of this matrix provides the ultimate in flexibility by allowing the use of any combination of DVI, ELR, or 1FO output modules in any of its four output slots. This feature allows the GefenPRO 32x32 Modular Matrix to function as both a Matrix and as an Extender. The front-panel LCD displays the current routing status and each DVI source is accessible to any display by using the front-panel push buttons, via the RS-232 interface, or through IP Control (built-in Web server and Telnet). Hot-swappable dual redundant power supplies allow these matrixes to be used for applications in demanding applications where enhanced reliability, ease of servicing and zero down-time are required.

## **How It Works**

Connect up to 32 DVI source devices using DVI cables to the inputs on the GefenPRO Modular Matrix. Connect up to 32 displays via DVI, CAT-5, or Fiber Optic cables depending on which output modules are utilized. Connect an Ethernet cable from the network to the RJ-45 connector to use the built-in Web server or Telnet capability to control routing, EDID, and other functions. Connect an RS-232 cable from a RS-232 control device to control the matrix via RS-232. Connect the IEC connectors of the included AC power cords to the matrix and plug the power cords into available electrical outlets. The DVI sources will be routed as selected.

# INTRODUCTION

---

## Features

- Supports resolutions up to 1920 x 1200
- Modular inputs and outputs organized into banks of 8 input or output devices
- Advanced EDID management for rapid integration of sources and displays
- RS-232 Serial interface for remote control via a computer or automation control system
- Front-panel LCD display
- Front-panel push buttons for local switching
- Built-in Web server, Telnet, and UDP control via IP
- Routing states can be stored and recalled at the touch of a button
- Dual redundant hot-swappable power supplies
- Removable and replaceable fan and filter
- Output masking command
- Standby mode
- Power ON / OFF switch
- Rack-mountable

## Package Includes

See the information beginning on the next page for details on the available pre-configured options.



# INTRODUCTION

## Pre-Configured Options

Before reading this User Manual, familiarize yourself with the rear panel of the 32x32 Modular Matrix.

The 32x32 Modular Matrix can accommodate up to four output cards and four input cards. Each card provides eight connectors, providing a total of 32 inputs and outputs. The 32x32 Modular Matrix is sold pre-configured with a combination of input and output cards best suited for the needs of your application. We will cover each configuration in the next section. First, we will identify the location of each input and output card on the matrix.



**NOTE:** When a card is not installed, it is recommended that a cover plate be installed over the expansion bay to prevent dust and other foreign particles from entering the matrix.

### Matrix Layout

The bottom-four expansion bays of the matrix only accept *input* cards. The top-four expansion bays only accept *output* cards. Each expansion bay on the matrix is identified with a letter: A, B, C, and D, from top to bottom (see next page).

The inputs and outputs are numbered on each card, from left-to-right.

Blue LEDs on each card indicate that the card is properly powered.

Refer to page 10 for detailed information on the rear-panel layout.

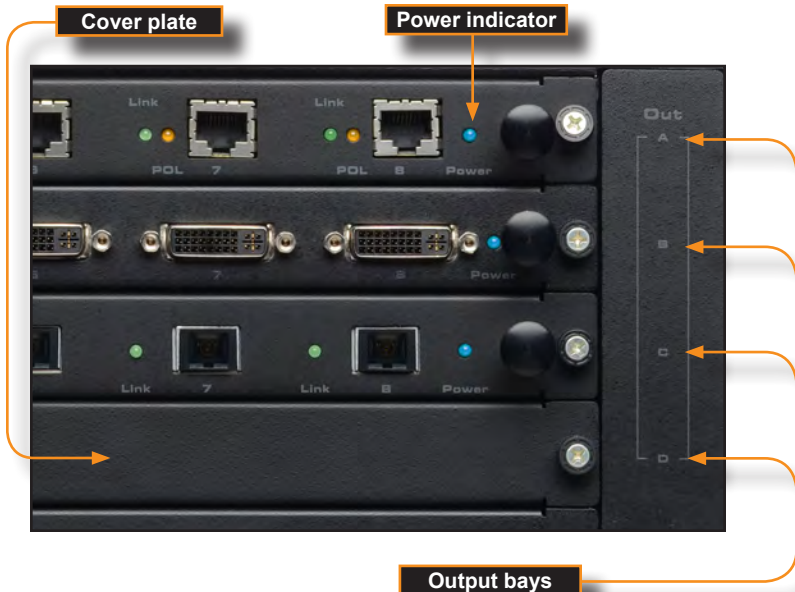

# INTRODUCTION

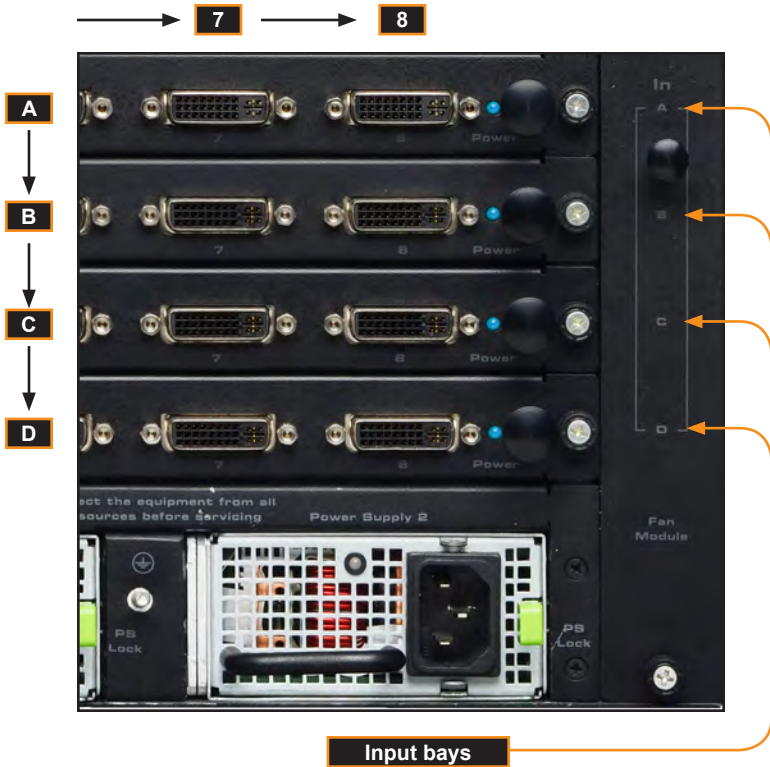

The following list outlines the available pre-configured options. Because this User Manual covers information on all available configurations, it is important to identify the type of 32x32 Modular Matrix that you have purchased:

- **GEF-MOD-32432-DVI**

Four input cards. Each card contains eight DVI inputs, providing a total of 32 DVI inputs.

Four output cards. Each card contains eight DVI outputs, providing a total of 32 DVI outputs.

**Package Includes:**

- (1) 32x32 Modular Matrix Frame
- (1) DB-9 cable
- (2) AC power cords
- (4) Modular Matrix 8 DVI Input Cards
- (4) Modular Matrix 8 DVI Output Cards
- (1) Quick-Start guide

# INTRODUCTION

---

- **GEF-MOD-32432-DVIELR**

Four input cards. Each card contains eight DVI inputs, providing a total of 32 DVI inputs.

Four output cards. Each card contains eight ELR-POL outputs. Each of these ELR-POL outputs are connected to a Receiver unit, using a CAT-5e cable, allowing you to extend the DVI signal up to 330 feet (100 meters). 32 ELR-POL Receiver units are included with this package option.

**Package Includes:**

- (1) 32x32 Modular Matrix Frame
- (1) DB-9 Cable
- (2) AC Power Cords
- (4) Modular Matrix 8 DVI Input Cards
- (4) Modular Matrix 8 DVI Sender over CAT-5 Cards
- (32) DVI ELR Receivers with POL
- (1) Quick-Start guide

- **GEF-MOD-32432-DVI1FO**

Four input cards. Each card contains eight DVI inputs, providing a total of 32 DVI inputs.

Four output cards. Each card contains eight SC-type fiber optic connectors. Each of these fiber optic connectors are connected to a Receiver unit, allowing you to extend the DVI signal up to 6600 feet (2 kilometers) using 50 $\mu$  OM3e multimode fiber optic cable. OM3 and OM1 fiber are also supported. 32 fiber optic Receiver units are included with this package option.

**Package Includes:**

- (1) 32x32 Modular Matrix Frame
- (1) DB-9 Cable
- (2) AC Power Cords
- (4) Modular Matrix 8 DVI Input Cards
- (4) Modular Matrix 8 DVI Sender over 1FO Cards
- (32) DVI Modular Receivers over 1FO
- (1) Quick-Start guide

# INTRODUCTION

---

- **GEF-MOD-32432-FM10001FO**

Four input cards. Each card contains eight DVI inputs, which provides a total of 32 DVI inputs. In addition, this package option includes 32 DVI FM 1000 Plus Extender Sender/Receiver pairs which allows you to connect DVI source devices from up to 1 kilometer away from the matrix.

Four output cards. Each card contains eight SC-type fiber optic connectors. Each of these fiber optic connectors are connected to a Receiver unit, allowing you to extend the DVI signal up to 6600 feet (2 kilometers) using 50 $\mu$  OM3e multimode fiber optic cable. OM3 and OM1 fiber are also supported. 32 fiber optic Receiver units are included with this package option.

**Package Includes:**

- (1) 32x32 Modular Matrix Frame
- (1) DB-9 Cable
- (2) AC Power Cords
- (4) Modular Matrix 8 DVI Input Cards
- (4) Modular Matrix 8 DVI Sender over 1FO Cards
- (32) DVI Modular Receivers over 1FO
- (32) DVI FM 1000 Plus Extenders (Sender / Receiver)
- (1) Quick-Start guide

- **GEF-MOD-32432-DPDVI**

Four input cards. Each card contains eight DisplayPort inputs, providing a total of 32 DisplayPort inputs.

Four output cards. Each card contains eight DVI outputs, providing a total of 32 DVI outputs.

**Package Includes:**

- (1) 32x32 Modular Matrix Frame
- (1) DB-9 Cable
- (2) AC Power Cords
- (4) Modular Matrix 8 DisplayPort Cards
- (4) Modular Matrix 8 DVI Output Cards
- (1) Quick-Start guide

# INTRODUCTION

---

- **GEF-MOD-32432-DPELR**

Four input cards. Each card contains eight DisplayPort inputs, providing a total of 32 DisplayPort inputs.

Four output cards. Each card contains eight ELR-POL outputs. Each of these ELR-POL outputs are connected to a Receiver unit, using a CAT-5e cable, allowing you to extend the DisplayPort signal up to 330 feet (100 meters). 32 ELR-POL Receiver units are included with this package option.

**Package Includes:**

- (1) 32x32 Modular Matrix Frame
- (1) DB-9 Cable
- (2) AC Power Cords
- (4) Modular Matrix 8 DisplayPort Cards
- (4) Modular Matrix 8 DVI Sender over CAT-5 Cards
- (32) DVI ELR Receivers with POL
- (1) Quick-Start guide

- **GEF-MOD-32432-DP1FO**

Four input cards. Each card contains eight DisplayPort inputs, providing a total of 32 DisplayPort inputs.

Four output cards. Each card contains eight SC-type fiber optic connectors. Each of these fiber optic connectors are connected to a Receiver unit, allowing you to extend the DisplayPort signal up to 6600 feet (2 kilometers) using 50 $\mu$  OM3e multimode fiber optic cable. OM3 and OM1 fiber are also supported. 32 fiber optic Receiver units are included with this package option.

**Package Includes:**

- (1) 32x32 Modular Matrix Frame
- (1) DB-9 Cable
- (2) AC Power Cords
- (4) Modular Matrix 8 DisplayPort Input Cards
- (4) Modular Matrix 8 DisplayPort Sender over 1FO Cards
- (32) DVI Modular Receivers over 1FO
- (1) Quick-Start guide

If any of the items from these pre-configured packages are missing, call Gefen Technical Support between the hours of 8:00 AM and 5:00 PM, Monday through Friday, Pacific Time.

# INTRODUCTION

## Front Panel Layout

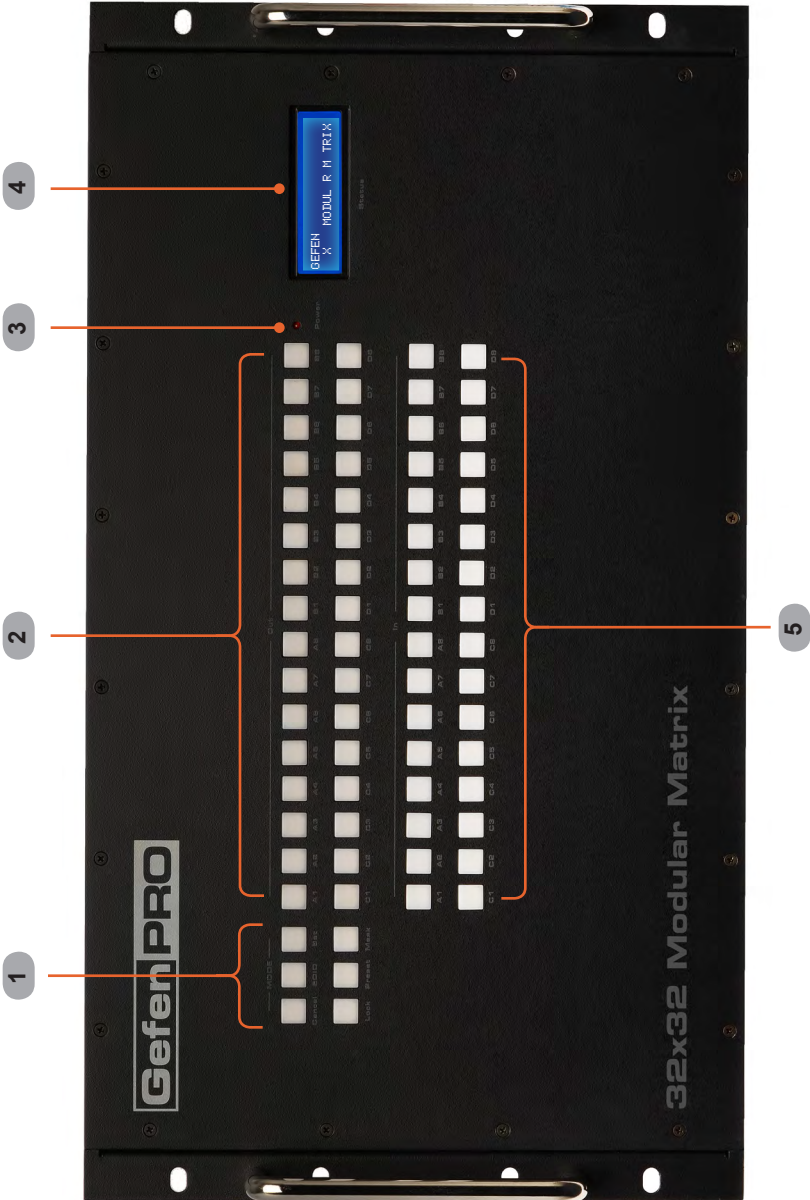

# INTRODUCTION

---

## Front Panel Descriptions

**1 Mode Buttons**

These buttons are used to control other features on the product. See pages 22 - 36 for more information.

**2 Output Buttons (1 - 32)**

Used for routing an Input to an Output. Each of these buttons represents an Output. See page 22 for more information on routing DVI sources.

**3 Power Indicator**

This LED indicator will glow red when the power is turned on.

**4 LCD Display**

Displays the current routing status of the Matrix and is also used to manage source routing.

**5 Input Buttons (1 - 32)**

Used for routing an Input to an Output. Each of these buttons represents an Input. See page 22 for more information on routing DVI sources.

# INTRODUCTION

## Back Panel Layout

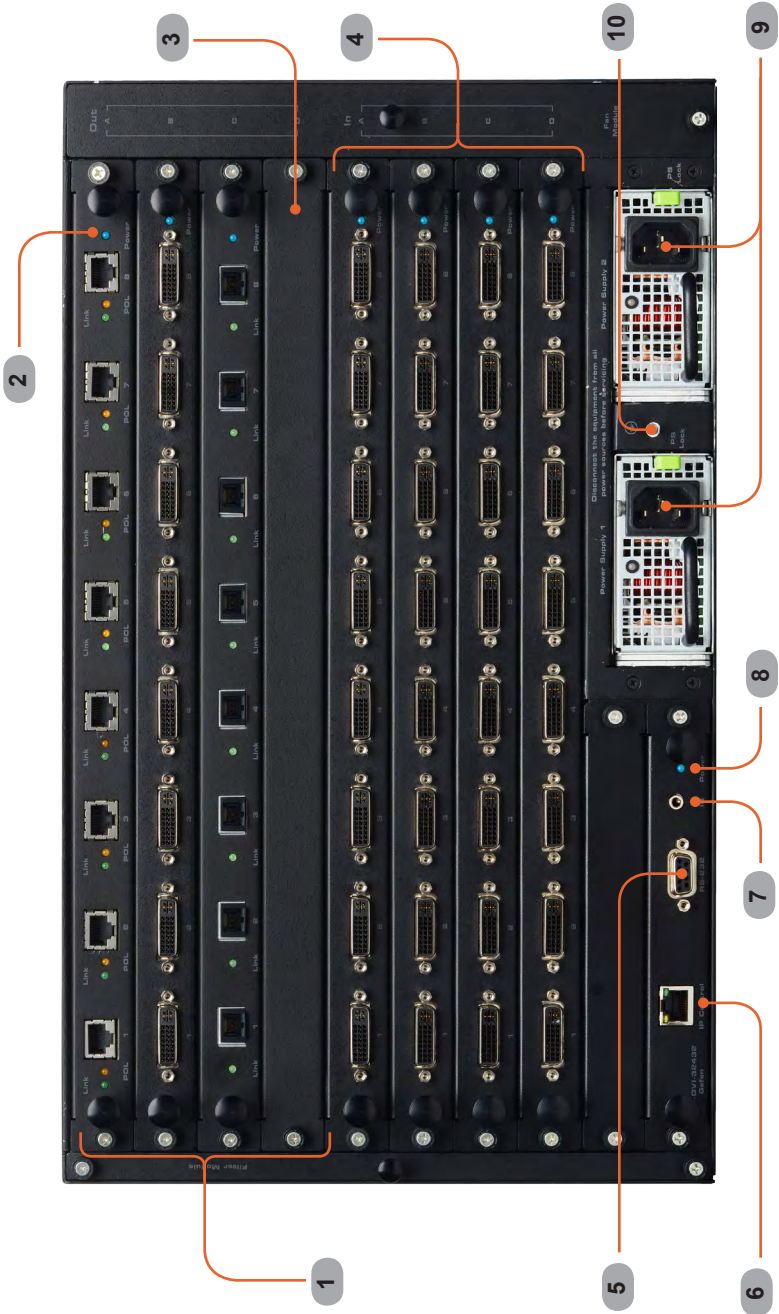



# INTRODUCTION

---

## Back Panel Descriptions

### 1 **Out (1 - 32)**

Connect the output devices to these ports. Output banks are shown using the GefenPRO ELR-POL Extender (GEF-DVI-8ELR-S), the GefenPRO Fiber Optic Extender (GEF-DVI-1FO-S), and the Gefen DVI Output Board (GEF-MOD-8DVI-O).

### 2 **Power (Input / Output boards)**

Each Input and Output card has its own power indicator. This LED indicator will glow bright blue when the card is properly installed and the power to the 32x32 Modular Matrix is applied.

### 3 **Cover Plate**

In the event that an Output (or Input) board is not required, the cover plate can be installed to prevent foreign particles or objects from entering the system.

### 4 **In (1 - 32)**

Connect the source devices to each of these ports. At the time of this writing, only DVI input modules are available.

### 5 **RS-232 Serial Port**

Connects to the RS-232 control device. The 32x32 Modular Matrix may be switched remotely using this port. See page 37 - 74 for more information.

### 6 **IP / UDP / Telnet Control**

Connect the 32x32 Modular Matrix to a network in order to use IP / UDP / Telnet control.

### 7 **IR**

Connect an IR extender to this IR port.

### 8 **Power**

This LED indicator glows bright blue when the matrix is powered on.

### 9 **Power Supply (1 - 2)**

Connect the included AC power cords from these receptacle to an available electrical outlet. The redundant (secondary) power cable should be connected to an electrical outlet on a different circuit. Each power supply is 110/220V AC.

### 10 **Grounding Terminal**

Provides a discharge path to ground in case a short circuit occurs between the "hot" lead of the power supply and the enclosure of the Matrix. The grounding wire should be attached from the grounding terminal to an approved ground path.



**NOTE:** Depending upon the package option of the 32x32 Modular Matrix that was purchased, the back-panel may differ.

# CONNECTING THE 32X32 MODULAR MATRIX

## Connections

Because there are several variations of the 32x32 Modular Matrix, we will cover each package option. Locate the connection instructions for the package which was purchased. The wiring diagram at the bottom of the page provides a general reference for connecting the 32x32 *Modular Matrix*. See the following pages for detailed connection instructions on each package option.

- GEF-MOD-32432-DVI.....13
- GEF-MOD-32432-DVIELR.....13
- GEF-MOD-32432-DVI1FO.....14
- GEF-MOD-32432-DVIFM10001FO.....16
- GEF-MOD-32432-DPDVI.....19
- GEF-MOD-32432-DPELR.....19
- GEF-MOD-32432-DP1FO.....19

## Wiring Diagram

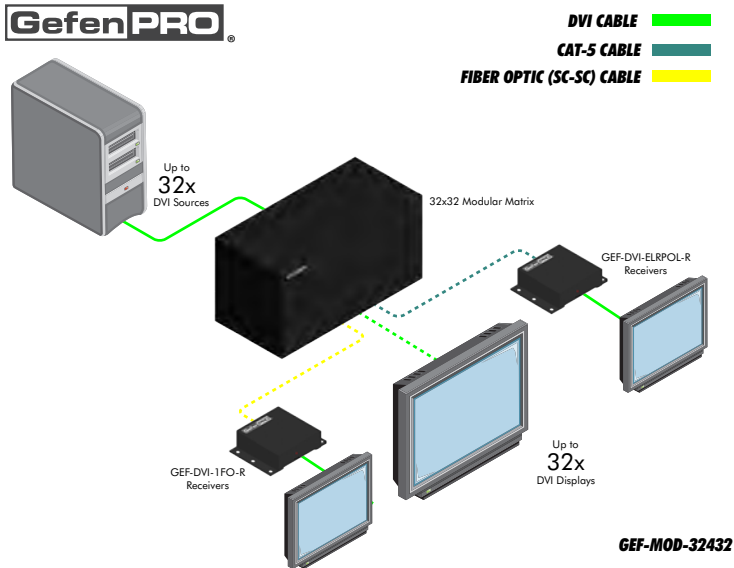

**WARNING:** This product should always be connected to a grounded electrical socket.

## CONNECTING THE 32X32 MODULAR MATRIX

### GEF-MOD-32432-DVI / GEF-MOD-32432-DPDVI

1. Connect up to 32 DVI sources to the DVI inputs on the rear panel of the 32x32 *Modular Matrix* using DVI cables.
2. Connect up to 32 DVI displays to the DVI outputs on the rear panel of the 32x32 *Modular Matrix*.
3. Connect both AC power cords from the 32x32 *Modular Matrix* to available electrical outlets. Connecting both AC power cords will provide redundancy should one of the power supplies fail. It is recommended to connect each power cord to electrical outlets on two separate circuits.

### GEF-MOD-32432-DVIELR

1. Connect up to 32 DVI sources to the DVI inputs on the rear panel of the 32x32 *Modular Matrix* using DVI cables.
2. Connect a CAT-5e cable (or better), up to 330 feet (100 meters) from each ELR-POL jack on the Sender card to each of the included ELR-POL Receiver units, as shown below.

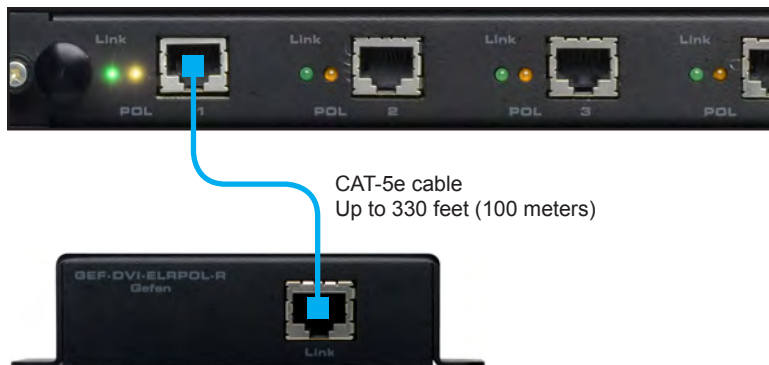

Once the matrix is powered, the Link indicators will glow bright green to indicate a solid link between the output card and the Receiver unit.

The POL indicators will glow bright amber to indicate that the Receiver unit is being powered.

(Continued on next page)

## CONNECTING THE 32X32 MODULAR MATRIX

3. Connect a DVI cable from the DVI Out port on each ELR-POL Receiver unit to a DVI display.

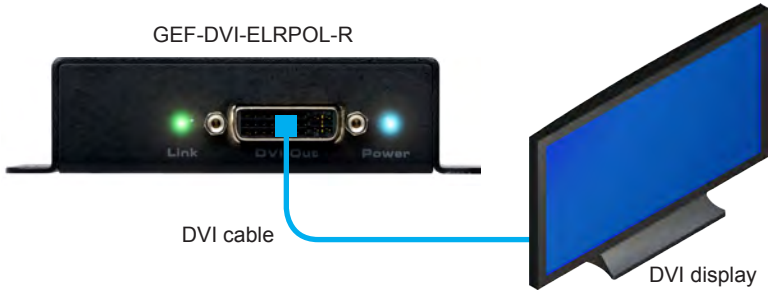

4. Connect both AC power cords from the 32x32 *Modular Matrix* to available electrical outlets. Connecting both AC power cords will provide redundancy should one of the power supplies fail. It is recommended to connect each power cord to electrical outlets on two separate circuits.

Power to the Receiver unit is delivered from the power supply in the matrix over the CAT-5e cable using Gefen Power Over Line (POL) technology. The Link indicator will glow bright green to indicate a solid connection between the matrix and the Receiver unit. The Power indicator will glow bright blue to indicate that the Receiver unit is being powered.

If either of these LED indicators are OFF, inspect the CAT-5 cable for loose connections or possible defects.

### GEF-MOD-32432-DVI1FO

1. Connect up to 32 DVI sources to the DVI inputs on the rear panel of the 32x32 *Modular Matrix* using DVI cables.
2. Connect a single strand of SC-terminated 50 $\mu$  OM3e multimode fiber optic cable from each SC connector on the Sender card to each Receiver unit, as shown below:

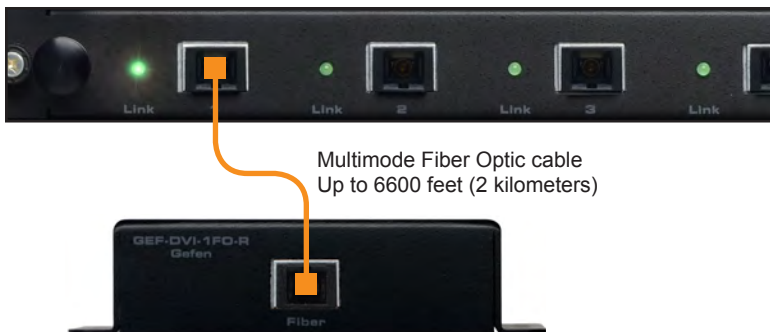

## CONNECTING THE 32X32 MODULAR MATRIX

50 $\mu$  OM3e, OM3, and 62.5 $\mu$  OM1 multimode fiber optic cable can be used. However, the maximum extension distance will be dependent upon the type of fiber optic cable used. Refer to the table, below.

Fiber type	Maximum Distance
multimode, 50 $\mu$ OM3e	6600 feet (2 kilometers)
multimode, 50 $\mu$ OM3	2000 feet (600 meters)
multimode, 62.5 $\mu$ OM1	660 feet (200 meters)

3. Connect the power supply to the 1FO Receiver unit then connect the power supply to an available electrical outlet.

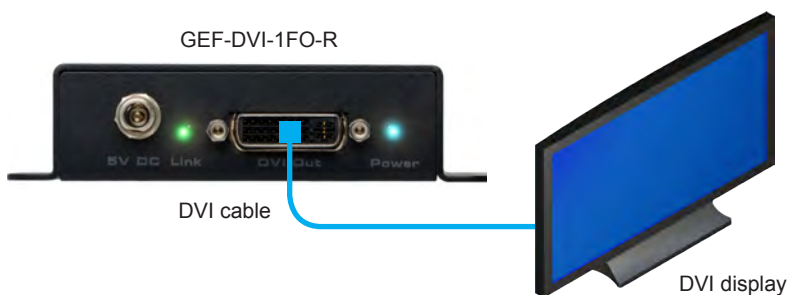

4. Connect both AC power cords from the matrix to available electrical outlets. Connecting both AC power cords will provide power redundancy should one of the power supplies fail. It is recommended to connect each AC power cord to separate circuits.

The Link indicator (on the Receiver unit) will glow bright green to indicate a connection between the matrix and the Receiver unit. If the Link indicator is OFF, then inspect the fiber optic cable for loose connections or possible defects.

The Power indicator will glow bright blue to indicate that the Receiver unit is powered.

# CONNECTING THE 32X32 MODULAR MATRIX

## GEF-MOD-32432-DVIFM10001FO

The GEF-MOD-32432-FM10001FO package comes with 32 pairs (Sender / Receiver) of DVI FM 1000 Plus fiber optic modules, allowing you to connect a DVI source device up to 3300 feet (1 kilometer) away from the matrix.



**IMPORTANT:** Before using the DVI FM 1000 PLUS fiber optic extenders, the Sender module must first be programmed with the EDID from the display (sink) device.

### Virtual EDID Programming Procedure

1. Power-on the DVI display and connect the DVI FM1000 PLUS Sender module directly to the DVI port of the display.

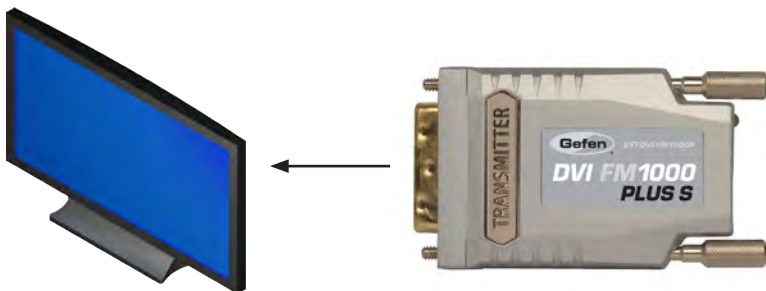

2. Connect the 5V DC power supply to the power receptacle on the Sender module. The LED indicator will begin to flash rapidly, indicating that the EDID is being recorded.

After the EDID has been successfully recorded, the LED indicator will glow bright green.



3. Disconnect the power supply from the Sender module.

## CONNECTING THE 32X32 MODULAR MATRIX

4. Disconnect the Sender module from the display.
5. Repeat Steps 1 - 4 for each Sender module that will be used in the setup.
6. Continue with instructions below in order to complete the connection process.

### Connecting the Sender and Receiver Modules

1. Connect each of the included DVI FM 1000 Plus Sender modules directly to each DVI source device.

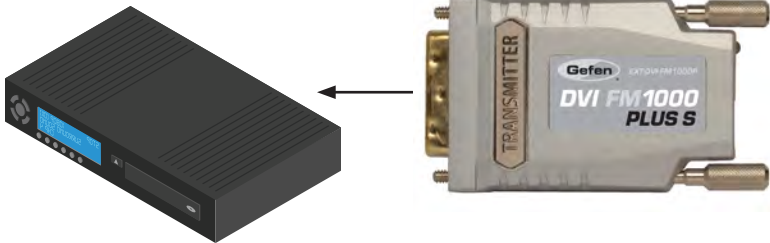

2. Connect each of the included DVI FM 1000 Plus Receiver modules to each of the DVI inputs on the 32x32 Modular Matrix.

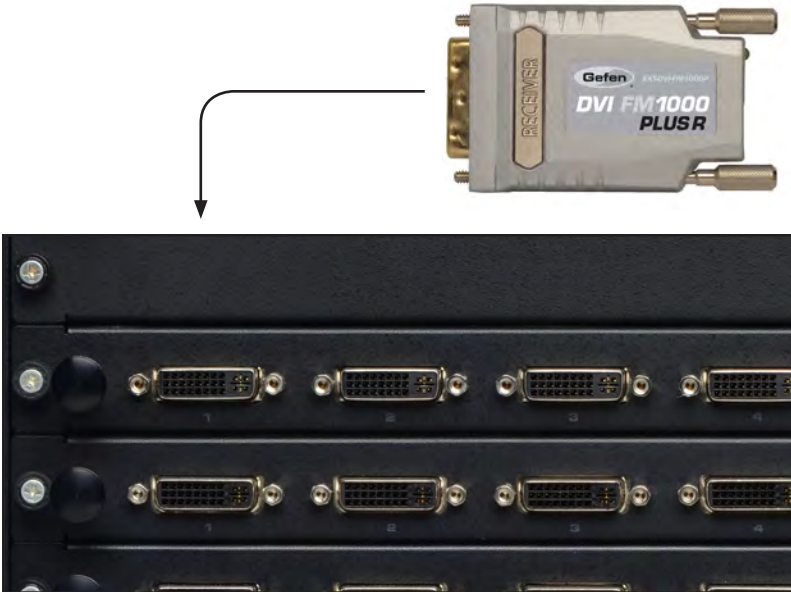

(Continued on next page)

## CONNECTING THE 32X32 MODULAR MATRIX

3. Connect a single strand of SC-terminated 50/125 $\mu$  OM3e multimode fiber optic cable from each SC connector on the Sender module to each associated Receiver module.

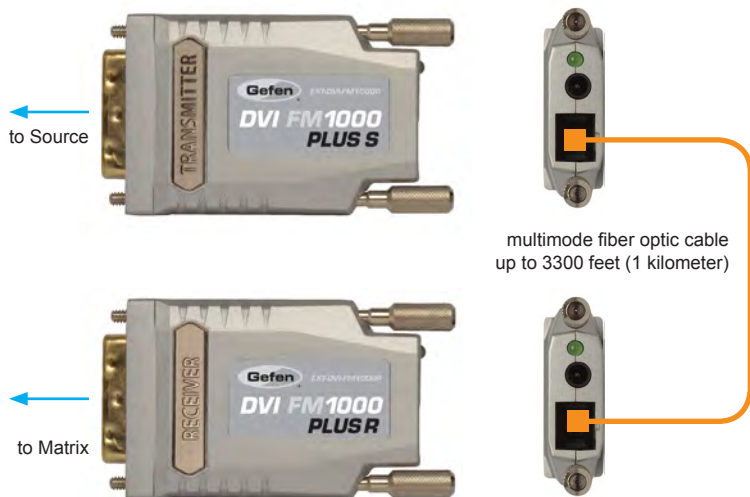

4. Once the DVI source is powered, the LED indicator (indicated by the arrow) on the Sender module will glow bright green. No external power supply is required.

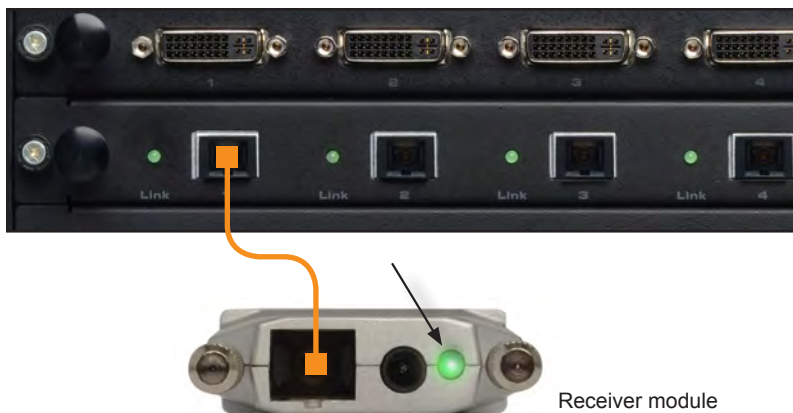

**NOTE:** If the LED indicator on the *Receiver module* does not turn on, then the 5V fiber optic feature must be enabled on the 32x32 Modular Matrix. Refer to the 32x32 Modular Matrix User Manual for details on using this feature.



# CONNECTING THE 32X32 MODULAR MATRIX

---

## DisplayPort package options

Each DisplayPort package is based on the DVI package options, except for the fact that all inputs will be DisplayPort instead of DVI. Refer to the connection instructions for the DVI version of each package if needed.

- **GEF-MOD-32432-DPDVI (based on the GEF-MOD-32432-DVI)**
  1. Connect the up to 32 DisplayPort sources to the DisplayPort inputs on the matrix.
  2. Connection up to 32 displays to the DVI outputs on the matrix using DVI cables.
  3. Power the matrix.
  
- **GEF-MOD-32432-DPELR (based on the GEF-MOD-32432-DVIELR)**
  1. Connect the up to 32 DisplayPort sources to each DisplayPort input on the matrix.
  2. Connect a CAT-5e cable (or better), up to 330 feet (100 meters) from each ELR-POL jack on the output card to each of the included ELR-POL Receiver units.
  3. Power the matrix.

Once the matrix is powered, the Link indicators will glow bright green to indicate a solid link between the Matrix card and the Receiver unit.

The POL indicators will glow bright amber to indicate that the Receiver unit is being powered.

- **GEF-MOD-32432-DP1FO (based on the GEF-MOD-32432-DVI1FO)**
  1. Follow the Virtual EDID Programming Procedure starting on page 16.
  2. Connect up to 32 DisplayPort sources to the DisplayPort inputs on the matrix.
  3. Connect a single strand of SC-terminated 50 $\mu$  OM3e multimode fiber optic cable from each SC connector on the Sender module to each Receiver module.

50 $\mu$  OM3e, OM3, and 62.5 $\mu$  OM1 multimode fiber optic cable can be used. However, the maximum extension distance is dependent upon the type of fiber optic cable used:

    - 6600 feet (2 kilometers) using 50 $\mu$  OM3e multimode fiber optic cable.
    - 2000 feet (600 meters) using 50 $\mu$  OM3 multimode fiber optic cable.
    - 660 feet (200 meters) using 62.5 $\mu$  OM1 multimode fiber optic cable.
  3. Connect the power supply to the 1FO Receiver unit then connect the power supply to an available electrical outlet.
  4. Power the matrix.

# OPERATING THE 32X32 MODULAR MATRIX

---

## Booting Up / Standby Screen

The front-panel LCD of the 32x32 Modular Matrix is a 16 character 2 line display. This display is used to aid in performing routing commands, as well as displaying additional system information. When the unit is powered on, the following screens are displayed:



After a few moments, the standby screen is displayed:



# OPERATING THE 32X32 MODULAR MATRIX

## Displaying the Current Routing State

To display the current routing status of the Matrix, press any one of the Input or Output buttons on the front panel.

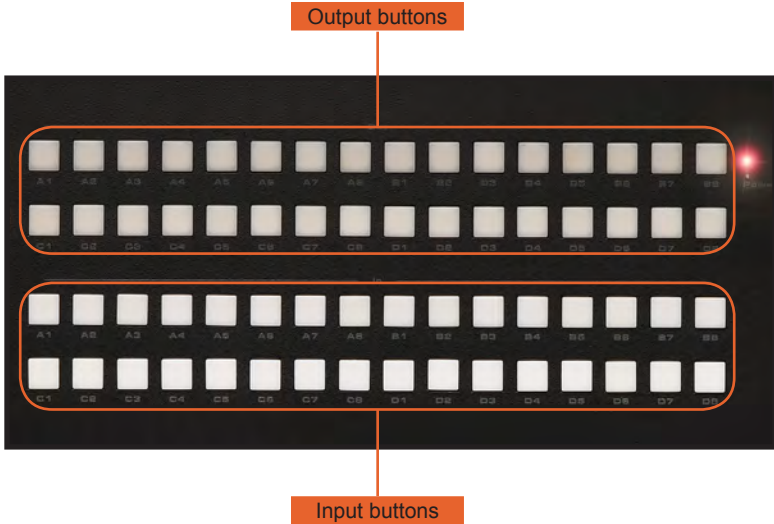

In the example above, Input A1 is routed to Output A4, Output A5, Output A7, Output A8, Output B1, Output B2, Output B3, Output C3, Output C5, and Output C6. A source does not need to be connected to the Matrix to display the current routing state. By default, all inputs are routed to their respective outputs (e.g. A1 - A1, A2 - A2, C3 - C3, D5 - D5, etc).

# OPERATING THE 32X32 MODULAR MATRIX

## Routing Sources

1. To change the current routing state, press the **Set** button to activate Routing Mode.

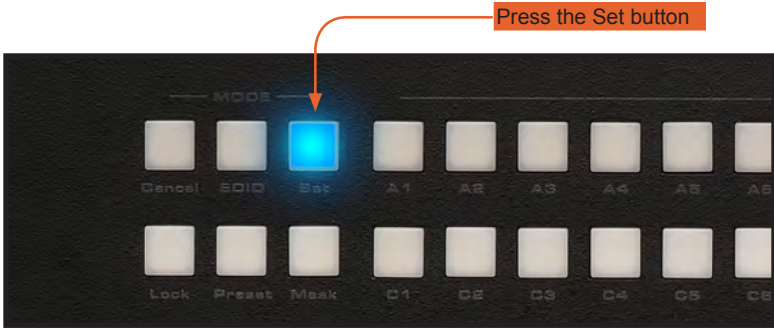

The front-panel LCD will indicate that Routing Mode has been selected:



2. Press the desired Output button(s) from the top two rows of push-buttons. One or more Output buttons may be selected.

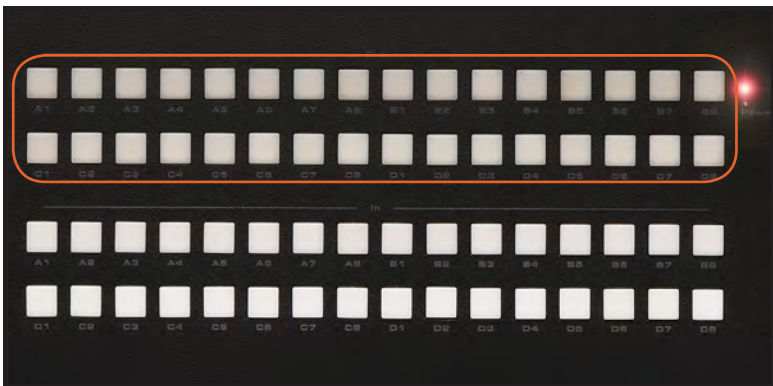

## OPERATING THE 32X32 MODULAR MATRIX

3. Select any Input from the bottom two rows of buttons (A1 - D8), corresponding to the source to be displayed on the output(s).

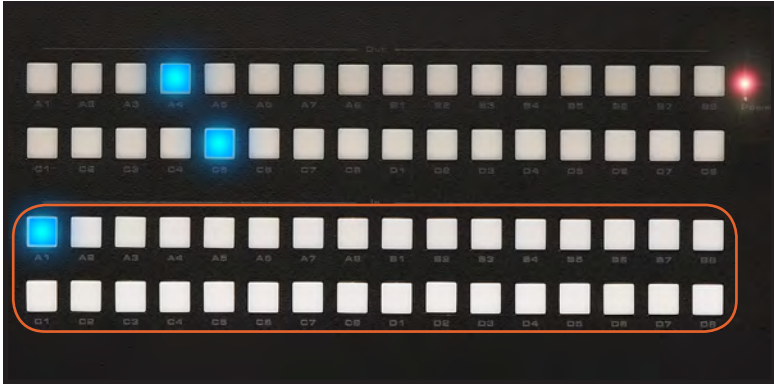

4. Press the **Set** button again to complete the operation.

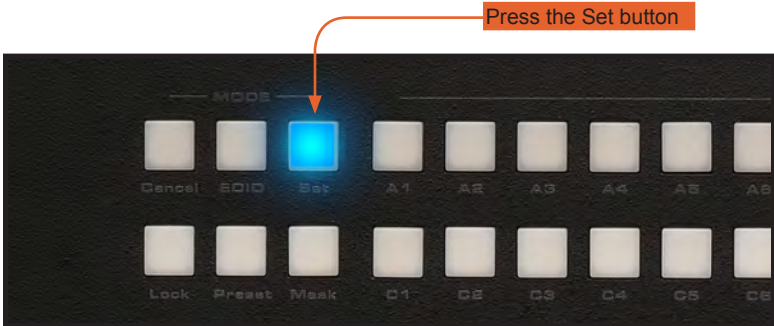

The front-panel LCD display will indicate that the routing process is complete:



# OPERATING THE 32X32 MODULAR MATRIX

## Locking the Matrix

Locking the Matrix prevents changes to any of the Matrix settings. This feature is useful in case any of the front panel buttons are pressed by accident. Locking the Matrix also prevents changes using the IR Remote Control Unit.

1. Press the Lock button to activate System Lock Mode.



The front-panel LCD screen will display the following while in System Lock Mode:



2. Press the Lock button a second time to deactivate System Lock Mode.



# OPERATING THE 32X32 MODULAR MATRIX

## Using the Cancel button

Press the **Cancel** button, while in any mode, to return to cancel the current function and display the Standby Mode screen.

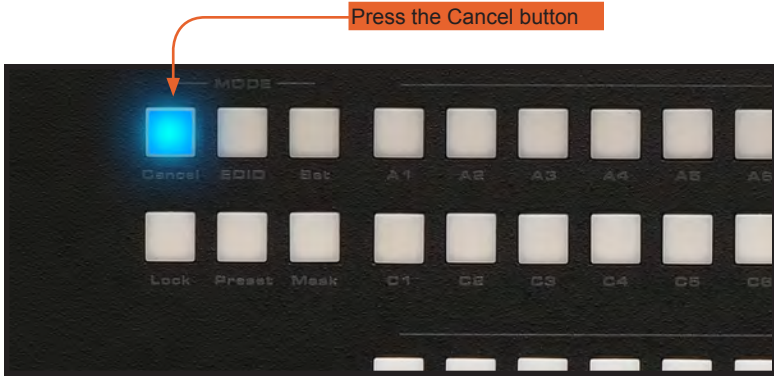

The 32x32 Modular Matrix front-panel LCD screen as it appears in Standby mode:



# OPERATING THE 32X32 MODULAR MATRIX

## Cycling between Information Screens

Press the **Cancel** button more than once, while in Standby Mode, to cycle through each of the information screens:

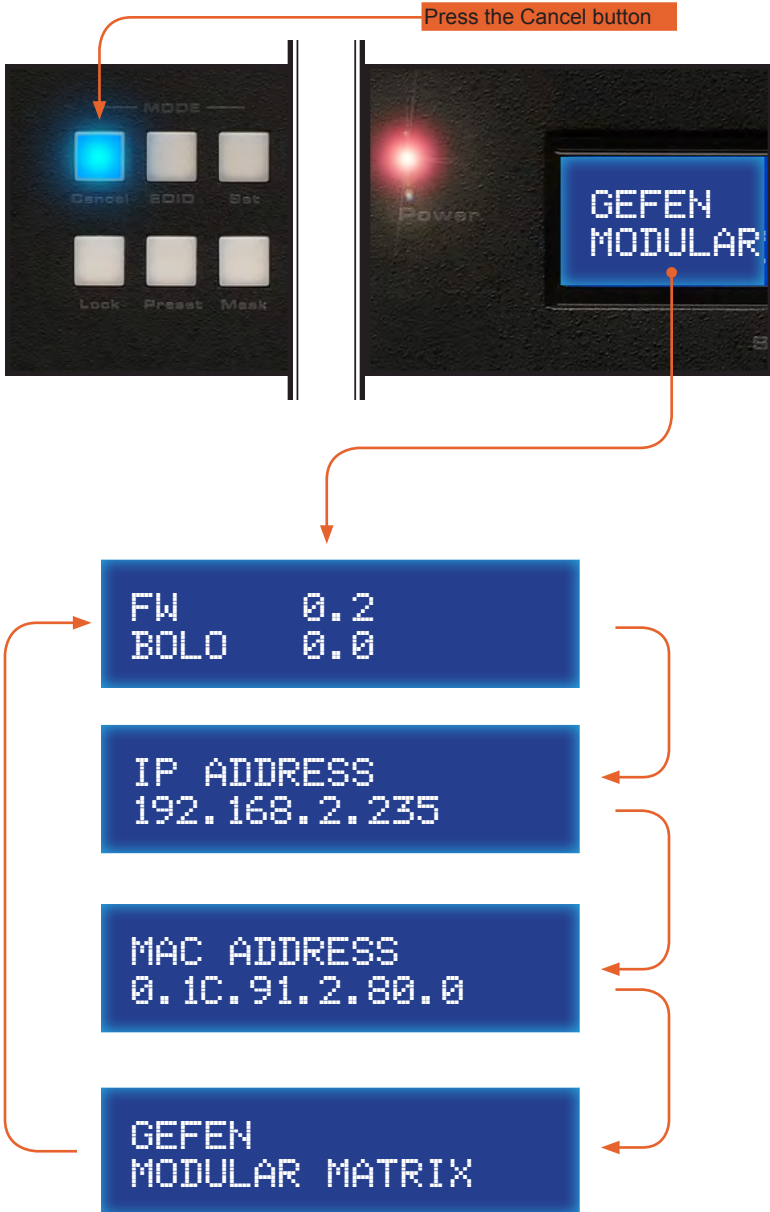



# OPERATING THE 32X32 MODULAR MATRIX

## Saving the current Routing State

1. Set the routing state (see page 22), then press the **PreSet** button *twice* to activate **Preset Mode**.

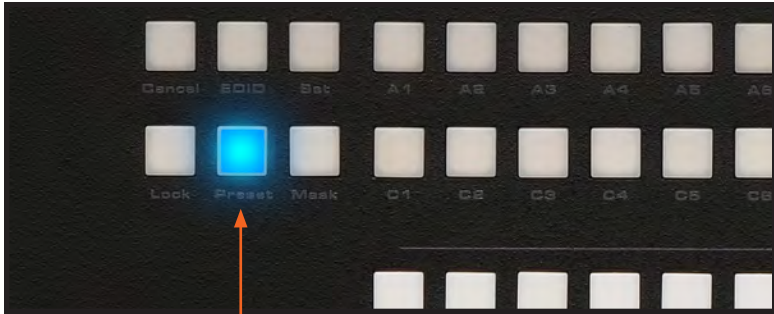

Press the **PreSet** button *twice*

After pressing the **PreSet** button once, the following will be displayed on the front-panel LCD screen:



Press the **PreSet** button again. The following will be displayed on the front-panel LCD screen:



# OPERATING THE 32X32 MODULAR MATRIX

2. Press an Input button (A1 - D8) to store the current routing state.

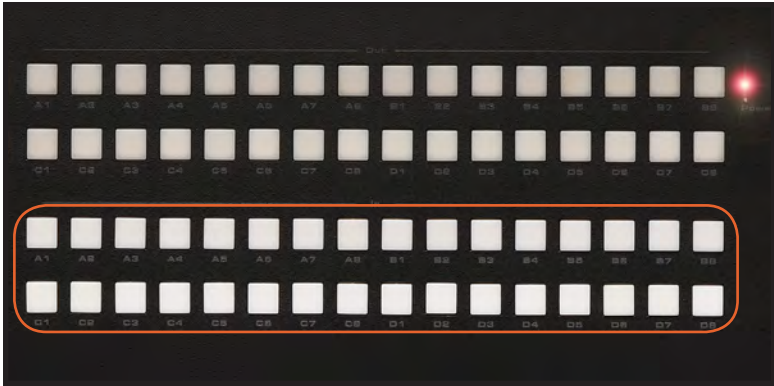

3. Press the **Set** button to complete the operation. The system will remain in Save Current Preset Mode.

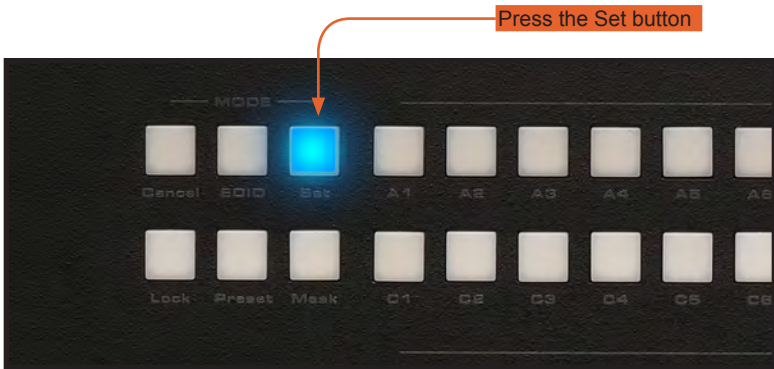

The front-panel LCD screen will indicate that the current routing state has been saved:



# OPERATING THE 32X32 MODULAR MATRIX

## Recalling a stored Routing State

1. Press the **PreSet** button *once* to activate Recall Preset Mode.

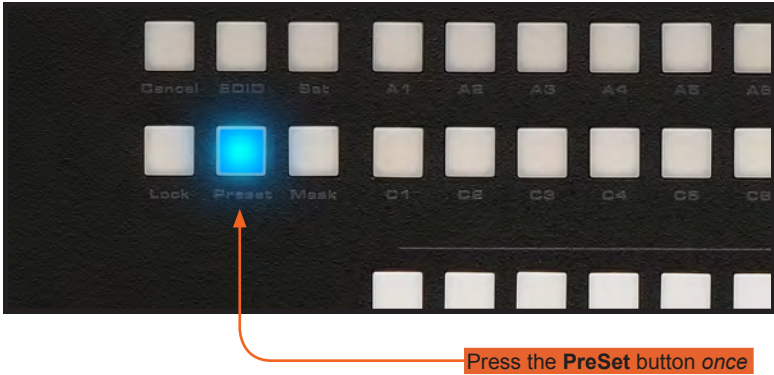

The following will be displayed on the front-panel LCD screen:



2. Press the Input button (A1 - D8) of the routing state to be recalled.

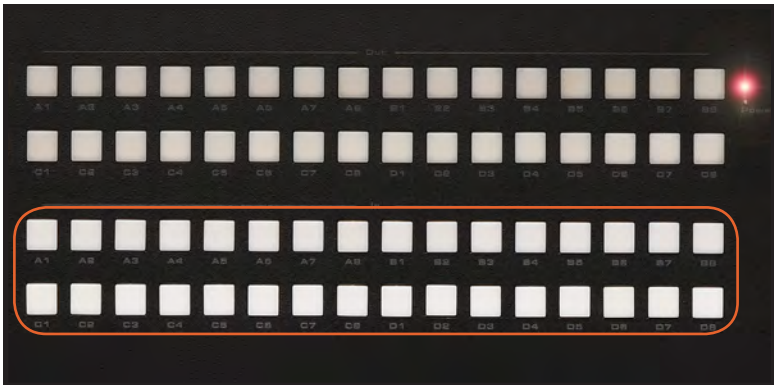

## OPERATING THE 32X32 MODULAR MATRIX

3. Press the **Set** button to complete the operation. The system will remain in Save Current Preset Mode.

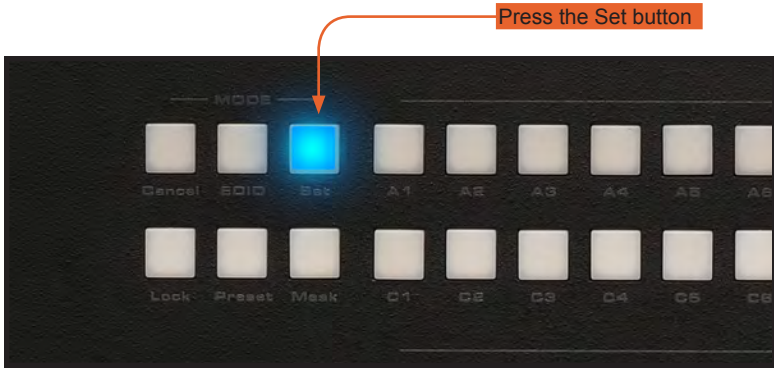

The front-panel LCD screen will indicate that the current routing state has been recalled:



# OPERATING THE 32X32 MODULAR MATRIX

## Masking Outputs

Masking prevents the output device (display, etc) from receiving an output signal, instead of powering-down the output device. The masking process is identical for masking or unmasking outputs.

1. Press the **Mask** button to activate Mask Mode.

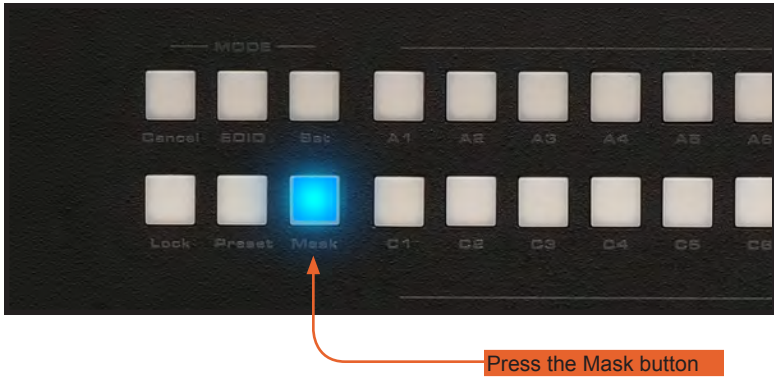

The front-panel LCD screen will indicate that the 32x32 Modular Matrix is in Mask Mode:



# OPERATING THE 32X32 MODULAR MATRIX

2. Select the Output (A1 - D8) to be masked:



3. Press the **Set** button to complete the operation.

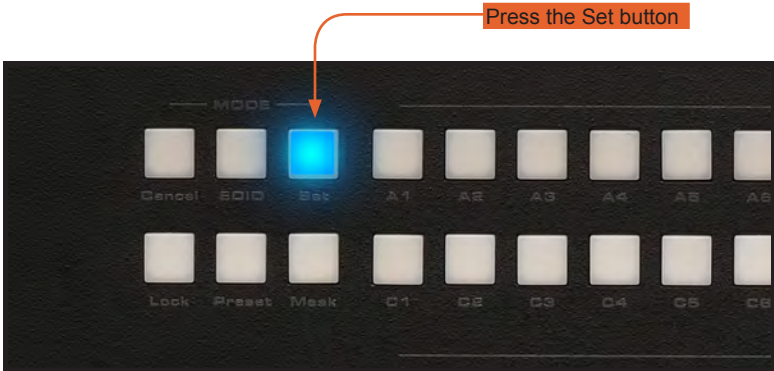

The front-panel LCD screen will indicate that the selected output has been masked:



# OPERATING THE 32X32 MODULAR MATRIX

## Managing EDID

*Saving the Downstream EDID data to Local memory:*

1. Press EDID button once to activate DSTOLO (Downstream To Local) Mode.



The front-panel LCD display will show the following:



2. Press the Output button (A1 - D8) to select the EDID source:



# OPERATING THE 32X32 MODULAR MATRIX

3. Press any Input button (A1 - D8) to select the EDID data destination:



4. Press the **Set** button to complete the operation.

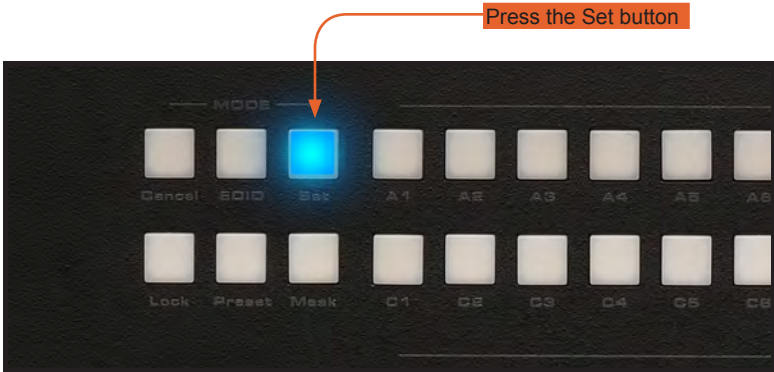



# OPERATING THE 32X32 MODULAR MATRIX

## *Saving the Default EDID data to Local memory*

1. Press the EDID button twice to activate DETOLO (Default To Local) Mode.



The front-panel LCD will display the following:



2. Press any Input button(s) (A1 - D8) to select the EDID data destination(s).

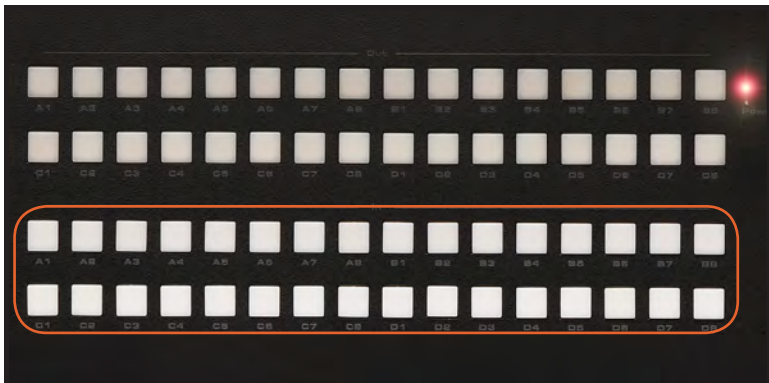

## OPERATING THE 32X32 MODULAR MATRIX

3. Press the **Set** button to copy the default EDID to the selected Input.

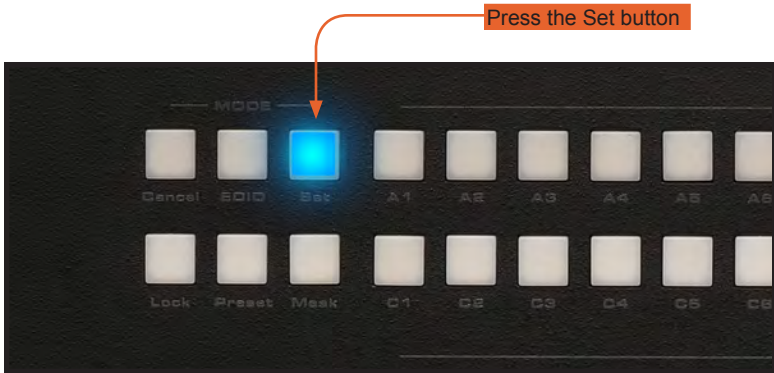

The front-panel LCD will indicate that the EDID is being copied:



After a few moments, the front-panel LCD will indicate that the EDID copy process has completed:



# RS-232 / IP / UDP CONTROL

## RS-232 Interface

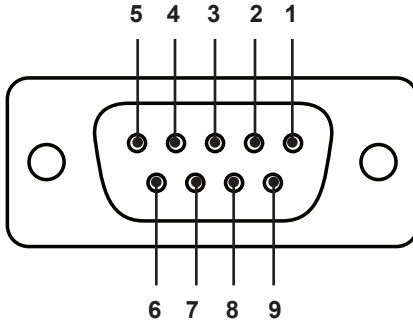

RS-232 Controller

Matrix

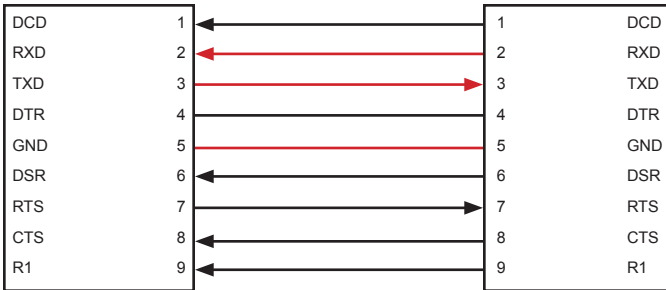

Only TXD, RXD, and GND are used.

## RS232 Settings

Baud rate .....19200  
 Data bits ..... 8  
 Parity bits ..... None  
 Stop bits .....1  
 Flow Control ..... None



**IMPORTANT:** When sending RS-232 commands, a carriage return must be included at the end of the command. A space *must* be included between the command and the parameter.

## IP Configuration

The *32x32 Modular Matrix* supports IP-based control using Telnet, UDP, or the built-in Web-based GUI. To set up IP control, the network settings for the *32x32 Modular Matrix* must be configured via RS-232. The default network settings for the matrix are as follows:

IP Address:	192.168.1.72
Subnet:	255.255.255.0
Gateway:	192.168.1.254
HTTP Port:	80
Telnet Port:	23

1. Connect an RS-232 cable from the PC to the *32x32 Modular Matrix*. Also make sure that an Ethernet cable is connected between the matrix and the network.
2. Launch a terminal emulation program (e.g. HyperTerminal) and use the RS-232 settings listed on page 37.



**NOTE:** Depending upon the network, all related IP, Telnet, and UDP settings will need to be assigned. Consult your network administrator to obtain the proper settings.

3. Set the IP address for the matrix using the `#sipadd` command (see page 55 for details).
4. Set the subnet mask using the `#snetmask` command (see page 55 for details).
5. Set the gateway (router) IP address using the `#sgateway` command (see page 53 for details).
6. Set the Telnet listening port using the `#set_tcp_term_port` command (see page 51 for details).
7. Set the HTTP listening port using the `#set_http_port` command (see page 50 for details).
8. Power-cycle the matrix to reboot and complete all IP setting changes.
9. Type the IP address that was specified in step 3, in a web browser to access the Web GUI or use the same IP address to Telnet to the matrix.

## UDP Configuration

1. Set the UDP remote IP address for the matrix using the `#set_udp_rip` command (see page 52 for details).
2. Set the UDP listening port for the matrix using the `#set_udp_port` command (see page 52 for details).
3. Set the UDP remote port for the matrix using the `#set_udp_rport` command (see page 53 for details).

# RS-232 / IP / UDP CONTROL

## RS-232 / Telnet Commands

EDID Management	
Command	Description
<code>#edidbatolo</code>	Read downstream EDID and stores in any Local Input
<code>#ediddetolo</code>	Set to default EDID on Local Input
<code>#ediddstoba</code>	Read downstream EDID and stores in EDID Bank
<code>#ediddstolo</code>	Read downstream EDID and stores into a Local EDID
<code>#lock_edid</code>	Locks Local EDID and disables auto-loading after power-up
<code>#loedidtoba</code>	Loads Local EDID to the specified EDID bank
<code>#loedidtolo</code>	Loads EDID to Local EDID
<code>#prbaedid</code>	Read downstream EDID from bank and sends to serial port
<code>#prdsedid</code>	Read downstream EDID and sends to serial port
<code>#predidst</code>	Spools the EDID details to the serial port
<code>#prioedid</code>	Read Input Local EDID and sends to serial port
<code>#set_bank_name</code>	Set the name of the specified EDID bank
<code>#show_bank_name</code>	Displays the name of the specified EDID bank

### #edidbatolo Command

The `#edidbatolo` command loads the EDID from the specified EDID bank and writes it to the specified input(s).

#### Syntax:

```
#edidbatolo param1 param2 param3...param9
```

#### Parameters:

<i>param1</i>	EDID bank offset	[1 ... 20]
<i>param2 - param9</i>	Input list	[0 ... 32]

#### Notes:

If *param2* = 0, then the EDID in the specified bank is copied to all 32 inputs.

#### Example:

```
#edidbatolo 2 3 6 7
```

```
Loading EDID bank 2 to locals Inputs: 3 6 7, please wait.....  
Finished Loading
```

### **#ediddetolo Command**

The #ediddetolo command stores the default (Internal) EDID to the specified input(s).

#### Syntax:

```
#ediddetolo param1 param2 param3...param9
```

#### Parameters:

*param1 - param32*                      Input list                      [1 ... 32]

#### Notes:

If *param1* = 0, then the default EDID will be stored in all 32 inputs.

#### Examples:

```
#ediddetolo 5 6 7
```

```
Loading default EDID to locals Inputs: 5 6 7, please wait.....  
Finished Loading
```

```
#ediddetolo 0
```

```
Loading default EDID to all locals Inputs, please wait.....  
Finished Loading
```

## #ediddstoba Command

The #ediddstoba command reads the downstream EDID and stores it to the specified EDID bank.

### Syntax:

```
#ediddstoba param1 param2
```

### Parameters:

<i>param1</i>	A downstream display	[1 ... 32]
<i>param2</i>	EDID bank offset	[1 ... 20]

### Example:

```
#ediddstoba param1 param2
```

```
Loading Downstream EDID 25 to EDID bank 20, please wait....  
Finished Loading
```

## #ediddstolo Command

The #ediddstolo command reads the downstream EDID and stores it to a Local EDID.

### Syntax:

```
#ediddstolo param1 param2 param3...param9
```

### Parameters:

<i>param1</i>	A downstream display	[1 ... 32]
<i>param2 - param9</i>	Input list	[1 ... 32]

### Notes:

If *param2* = 0, then the downstream EDID is stored in all 32 inputs.

### Example:

```
#ediddstolo 25 6 7
```

```
Loading Downstream EDID 25 to locals Inputs: 6 7, please wait.....  
Finished Loading
```

## #lock\_edid Command

The #lock\_edid command secures the EDID stored on all inputs. This prevents the default EDID from being loaded to all inputs during a power-up procedure. This feature can be enabled or disabled.

### Syntax:

```
#lock_edid param1
```

### Parameters:

*param1* EDID lock state [0 ... 1]

Value	Meaning
0	Disable
1	Enable

## #loedidtoba Command

The #loedidtoba command loads an EDID file and stores it in the specified EDID bank.

### Syntax:

```
#loedidtoba param1
```

### Parameters:

*param1* Bank [1 ... 20]

### Example:

```
#loedidtoba 8
```

```
=====
```

```
Download EDID bin file__1
```

```
cancel_____0
```

```
=====
```

```
Please send EDID bin file
```

```
Waiting for the file to be sent ... (press 'a' to abort)
```



## #loedidtolo Command

The #loedidtolo command loads an EDID file and stores it in the specified input.

### Syntax:

```
#loedidtolo param1
```

### Parameters:

<i>param1</i>	Input	[1 ... 32]
---------------	-------	------------

### Notes:

If *param1* = 0, then the downstream EDID is stored in all 32 inputs.

### Example:

```
#loedidtoba 8
```

```
=====
Download EDID bin file__1
cancel_____0
=====
```

```
Please send EDID bin file
```

```
Waiting for the file to be sent ... (press 'a' to abort)
```

## #prbaedid Command

The #prbaedid command displays the EDID stored in the specified EDID bank.

### Syntax:

```
#prbaedid param1
```

### Parameters:

<i>param1</i>	Bank	[1 ... 20]
---------------	------	------------

### Example:

```
#prbaedid 20  
Print the Bank EDID 20 on terminal screen
```

```
0x00 0xFF 0xFF 0xFF 0xFF 0xFF 0xFF 0x00  
0x10 0xAC 0x35 0x40 0x4C 0x32 0x33 0x32  
0x31 0x13 0x01 0x03 0x80 0x41 0x29 0x78  
0xEA 0x8F 0x95 0xAD 0x4F 0x32 0xB2 0x25  
0x0F 0x50 0x54 0xA5 0x4B 0x00 0x81 0x80  
0xA9 0x40 0xD1 0x00 0xD1 0x40 0x71 0x4F  
0x81 0x00 0xB3 0x00 0x01 0x01 0xB0 0x68  
0x00 0xA0 0xA0 0x40 0x2E 0x60 0x30 0x20  
0x36 0x00 0x81 0x90 0x21 0x00 0x00 0x1E  
0x00 0x00 0x00 0xFF 0x00 0x47 0x35 0x30  
0x31 0x48 0x39 0x43 0x32 0x32 0x33 0x32  
0x4C 0x0A 0x28 0x3C 0x80 0xA0 0x70 0xB0  
0x23 0x40 0x30 0x20 0x36 0x00 0x81 0x91  
0x21 0x00 0x00 0x1C 0x00 0x00 0x00 0xFD  
0x00 0x31 0x56 0x1D 0x71 0x1C 0x00 0x0A  
0x20 0x20 0x20 0x20 0x20 0x20 0x00 0x41
```

## #prdsedid Command

The #prdsedid command displays the specified downstream EDID.

### Syntax:

```
#prdsedid param1
```

### Parameters:

<i>param1</i>	Output	[1 ... 32]
---------------	--------	------------

### Example:

```
#prdsedid 20
```

Print the Downstream EDID 25 on terminal screen,, please wait...

```
0x00 0xFF 0xFF 0xFF 0xFF 0xFF 0xFF 0x00
0x10 0xAC 0x35 0x40 0x4C 0x32 0x33 0x32
0x31 0x13 0x01 0x03 0x80 0x41 0x29 0x78
0xEA 0x8F 0x95 0xAD 0x4F 0x32 0xB2 0x25
0x0F 0x50 0x54 0xA5 0x4B 0x00 0x81 0x80
0xA9 0x40 0xD1 0x00 0xD1 0x40 0x71 0x4F
0x81 0x00 0xB3 0x00 0x01 0x01 0xB0 0x68
0x00 0xA0 0xA0 0x40 0x2E 0x60 0x30 0x20
0x36 0x00 0x81 0x90 0x21 0x00 0x00 0x1E
0x00 0x00 0x00 0xFF 0x00 0x47 0x35 0x30
0x31 0x48 0x39 0x43 0x32 0x32 0x33 0x32
0x4C 0x0A 0x28 0x3C 0x80 0xA0 0x70 0xB0
0x23 0x40 0x30 0x20 0x36 0x00 0x81 0x91
0x21 0x00 0x00 0x1C 0x00 0x00 0x00 0xFD
0x00 0x31 0x56 0x1D 0x71 0x1C 0x00 0x0A
0x20 0x20 0x20 0x20 0x20 0x20 0x00 0x41
```

## #predidst Command

The #predidst command displays the EDID used by each input.

### Syntax:

```
#predidst
```

### Parameters:

None

### Example:

```
#predidst
```

EDID table

Input	Source	ID	Monitor name
1	Default	GFN	GEFEN_XPT_SL
2	Default	GFN	GEFEN_XPT_SL
3	Bank 2	MEI	PanasonicTV0
4	Bank 2	MEI	PanasonicTV0
5	Bank 2	MEI	PanasonicTV0
6	25	DEL	
7	25	DEL	
8	Bank 2	MEI	PanasonicTV0
9	Bank 2	MEI	PanasonicTV0
10	Bank 2	MEI	PanasonicTV0
11	Default	GFN	GEFEN_XPT_SL
12	Default	GFN	GEFEN_XPT_SL
13	Default	GFN	GEFEN_XPT_SL
14	Default	GFN	GEFEN_XPT_SL
15	Default	GFN	GEFEN_XPT_SL
16	Default	GFN	GEFEN_XPT_SL
17	Default	GFN	GEFEN_XPT_SL
18	Default	GFN	GEFEN_XPT_SL
19	Default	GFN	GEFEN_XPT_SL
20	Default	GFN	GEFEN_XPT_SL
21	Default	GFN	GEFEN_XPT_SL
22	Default	GFN	GEFEN_XPT_SL
23	Default	GFN	GEFEN_XPT_SL
24	Default	GFN	GEFEN_XPT_SL
25	Default	GFN	GEFEN_XPT_SL
26	Default	GFN	GEFEN_XPT_SL
27	Default	GFN	GEFEN_XPT_SL
28	Default	GFN	GEFEN_XPT_SL
29	Default	GFN	GEFEN_XPT_SL
30	Default	GFN	GEFEN_XPT_SL
31	Default	GFN	GEFEN_XPT_SL
32	Default	GFN	GEFEN_XPT_SL



## #set\_bank\_name Command

The #set\_bank\_name command sets the name of the specified EDID bank.

### Syntax:

```
#set_bank_name param1 param2
```

### Parameters:

<i>param1</i>	EDID Bank	[1 ... 20]
<i>param2</i>	Name	[20 chars max.]

### Notes:

Spaces are not permitted when naming EDID banks. If a space is required, use the underscore character ("\_").

### Example:

```
#set_bank_name 3 Dell_30"  
Dell_30" is assigned to bank 3
```

## #show\_bank\_name Command

The #show\_bank\_name command displays the name of the specified EDID bank.

### Syntax:

```
#show_bank_name param1
```

### Parameters:

<i>param1</i>	EDID Bank	[1 ... 20]
---------------	-----------	------------

### Example:

```
#show_bank_name 3  
Bank 3 - Dell_30"
```

IP Configuration	
Command	Description
<code>#ipconfig</code>	Displays the current IP configuration
<code>#resetip</code>	Sets IP configuration to factory settings
<code>#set_http_port</code>	Sets the Web server listening port
<code>#set_tcp_term_pass</code>	Sets the TCP terminal password
<code>#set_tcp_term_port</code>	Sets the TCP terminal port
<code>#set_udp_port</code>	Sets the UDP port
<code>#set_udp_rip</code>	Sets the remote UDP IP address
<code>#set_udp_rport</code>	Sets the remote UDP port
<code>#sgateway</code>	Sets the IP address of the (router) gateway
<code>#show_tcp_term_pass</code>	Displays the current TCP terminal password
<code>#sipadd</code>	Sets the IP Address
<code>#snetmask</code>	Sets the Net Mask
<code>#use_tcp_term_pass</code>	Enables / disabled login credentials
<code>#use_udp_access</code>	Enables / disabled UDP access

## #ipconfig Command

The `#ipconfig` command displays all TCP/IP settings.

### Syntax:

```
#ipconfig
```

### Parameters:

None

### Example:

```
#ipconfig
----- TCP/IP settings -----
MAC add   = 00:1C:91:02:80:2B
IP add    = 192.168.1.205
Net Mask  = 255.255.255.0
Gateway   = 192.168.1.1
Web Server Port = 80
TCP Terminal Server Port = 23
UDP Server Port = 21
TCP Terminal password at login is set to OFF
UDP Remote IP = 192.168.2.206
UDP Remote Port = 50021
UDP Access = Enabled
```

### **#resetip Command**

The #resetip command sets the current IP configuration to factory (default) settings.

#### Syntax:

```
#resetip
```

#### Parameters:

None

#### Notes:

A reboot is required after using this command.

### **#set\_http\_port Command**

The #set\_http\_port command specifies the Web server listening port. The default port setting is 80.

#### Syntax:

```
#set_http_port param1
```

#### Parameters:

<i>param1</i>	Port	[0 ... 255]
---------------	------	-------------

#### Notes:

A reboot is required after using this command.

#### Example:

```
#set_http_port 80  
New HTTP port set to: 80
```



### **#set\_tcp\_term\_pass Command**

The #set\_tcp\_term\_pass command sets the TCP terminal password.

#### Syntax:

```
#set_tcp_term_pass param1 param2 param3
```

#### Parameters:

<i>param1</i>	Old password	[20 chars max.]
<i>param2</i>	New password	[20 chars max.]
<i>param3</i>	New password (confirm)	[20 chars max.]

#### Notes:

A reboot is required after using this command.

#### Example:

```
#set_tcp_term_pass Admin reindeer reindeer  
TCP Terminal password updated to: reindeer
```

### **#set\_tcp\_term\_port Command**

The #set\_tcp\_term\_port command sets the TCP terminal server listening port. The default port setting is 23.

#### Syntax:

```
#set_tcp_term_port param1
```

#### Parameters:

<i>param1</i>	Port	[1 ... 65535]
---------------	------	---------------

#### Notes:

A reboot is required after using this command.

#### Example:

```
#set_tcp_term_port 21  
New TCP Terminal port set to: 21
```

### **#set\_udp\_port Command**

The #set\_udp\_port command sets the UDP server listening port. The default port setting is 21.

#### Syntax:

```
#set_udp_port param1
```

#### Parameters:

<i>param1</i>	Port	[1 ... 65535]
---------------	------	---------------

#### Notes:

A reboot is required after using this command.

#### Example:

```
#set_udp_port 56  
New UDP server port set to: 56
```

### **#set\_udp\_rip Command**

The #set\_udp\_rip command sets the remote UDP listening IP address. The IP address must be specified using dot-decimal notation. The default UDP remote IP address is 192.168.1.255.

#### Syntax:

```
#set_udp_rip param1
```

#### Parameters:

<i>param1</i>	IP Address
---------------	------------

#### Notes:

A reboot is required after using this command.

#### Example:

```
#set_udp_rip 192.168.1.255  
New Remote UDP IP set to: 192.168.1.255
```

### **#set\_udp\_rport Command**

The #set\_udp\_rport command sets the remote UDP listening port. The default UDP remote port is 50008.

#### Syntax:

```
#set_udp_rport param1
```

#### Parameters:

<i>param1</i>	Port	[1 ... 65535]
---------------	------	---------------

#### Notes:

A reboot is required after using this command.

#### Example:

```
#set_udp_rport 30  
New UDP Remote port set to: 30
```

### **#sgateway Command**

The #sgateway command sets the new IP gateway. The gateway must be typed using dot-decimal notation. The default gateway is 192.168.1.254.

#### Syntax:

```
#sgateway param1
```

#### Parameters:

<i>param1</i>	Gateway
---------------	---------

#### Notes:

A reboot is required after using this command.

#### Example:

```
#sgateway 192.168.1.1  
New IP Gateway set to: 192.168.1.1
```

### **#show\_tcp\_term\_pass Command**

The #show\_tcp\_term\_pass command displays the current TCP terminal password. The default TCP terminal password is Admin.

#### Syntax:

```
#show_tcp_term_pass
```

#### Parameters:

None

#### Example:

```
#show_tcp_term_pass  
TCP Terminal password: reindeer
```

### **#show\_user\_name Command**

The #show\_user\_name command displays the current TCP terminal user name. The default TCP terminal user name is Administrator.

#### Syntax:

```
#show_used_name
```

#### Parameters:

None

#### Example:

```
#show_user_name  
TCP Terminal login: Administrator
```



## #use\_tcp\_term\_pass Command

The #use\_tcp\_term\_pass command enables or disables the login credentials when starting a terminal session.

### Syntax:

```
#use_tcp_term_pass param1
```

### Parameters:

*param1* State [0 ... 1]

Value	Meaning
0	Disable
1	Enable

### Notes:

A reboot is required after using this command.

### Example:

```
#use_tcp_term_pass 1  
TCP Terminal password at login is set to ON
```

## #use\_udp\_access Command

The #use\_udp\_access command enables or disables UDP access mode.

### Syntax:

```
#use_udp_access param1
```

### Parameters:

*param1* State [0 ... 1]

Value	Meaning
0	Disable
1	Enable

### Notes:

A reboot is required after using this command.

### Example:

```
#use_udp_access 1  
UDP Access is set to Enabled
```

Routing and Masking	
Command	Description
<code>#callpreset</code>	Restores the specified routing / masking preset
<code>#maskout</code>	Masks the specified outputs
<code>#prpreset</code>	Displays the current list of presets
<code>#savepreset</code>	Saves the current routing / masking preset
<code>#set_input_name</code>	Assigns an input with the specified name
<code>#set_output_name</code>	Assigns an output with the specified name
<code>#set_preset_name</code>	Assigns a preset with the specified name
<code>#show_input_name</code>	Displays the specified input name
<code>#show_output_name</code>	Displays the specified output name
<code>#show_preset_name</code>	Displays the specified preset name
<code>#unmaskout</code>	Unmasks the specified outputs
<code>m</code>	Displays the current matrix status in tabular form
<code>r</code>	Routes the specified input to the specified outputs
<code>s</code>	Routes the specified inputs to all outputs

### **#callpreset Command**

The `#callpreset` command restores the specified routing / masking preset.

#### Syntax:

```
#callpreset param1
```

#### Parameters:

```
param1                Preset                [1 ... 16]
```

#### Notes:

If the specified preset is empty, then "Empty Set" will be returned.

#### Examples:

```
#callpreset 2
Recalling the saved routing state from preset 2
```

```
#callpreset 3
Recalling the saved routing state from preset 3
Empty Set
```

### **#maskout Command**

The #maskout command masks the specified outputs.

#### Syntax:

```
#maskout param1 param2 ... param8
```

#### Parameters:

*param1 - param8*                      Output                      [1 ... 32]

#### Notes:

If *param1* = 0, then all 32 outputs will be masked.

#### Examples:

```
#maskout 2 3 4  
Masked Outputs: 2 3 4
```

```
#maskout 0  
Masked all Outputs
```



# RS-232 / IP / UDP CONTROL

## #prpreset Command

The #prpreset command displays the current list of presets in tabular form.

### Syntax:

```
#prpreset
```

### Parameters:

None

### Example:

```
#prpreset
```

```
Preset table
```

```
Set | Outputs 1-32
```

```
1 | M 2 A 2 A 3 A 4 M 5 A 6 A 7 A 8 A 9 M10 M11 A12 A13 A14 A15 A16
   | A17 A18 A19 A20 A21 A22 A23 A24 A25 A26 A27 A28 A29 A30 A31 A32
2 | A22 A 2 A 3 A 4 A 5 A 6 A 7 A 8 A 9 A10 A11 A12 A13 A14 A15 A16
   | A17 A18 A19 A25 A17 A22 A23 A24 A17 A26 A27 A28 A29 A30 A31 A32
3 | A 0 A 0 A 0 A 0 A 0 A 0 A 0 A 0 A 0 A 0 A 0 A 0 A 0 A 0 A 0 A 0
   | A 0 A 0 A 0 A 0 A 0 A 0 A 0 A 0 A 0 A 0 A 0 A 0 A 0 A 0 A 0 A 0
4 | A 0 A 0 A 0 A 0 A 0 A 0 A 0 A 0 A 0 A 0 A 0 A 0 A 0 A 0 A 0 A 0
   | A 0 A 0 A 0 A 0 A 0 A 0 A 0 A 0 A 0 A 0 A 0 A 0 A 0 A 0 A 0 A 0
5 | A 0 A 0 A 0 A 0 A 0 A 0 A 0 A 0 A 0 A 0 A 0 A 0 A 0 A 0 A 0 A 0
   | A 0 A 0 A 0 A 0 A 0 A 0 A 0 A 0 A 0 A 0 A 0 A 0 A 0 A 0 A 0 A 0
6 | A 0 A 0 A 0 A 0 A 0 A 0 A 0 A 0 A 0 A 0 A 0 A 0 A 0 A 0 A 0 A 0
   | A 0 A 0 A 0 A 0 A 0 A 0 A 0 A 0 A 0 A 0 A 0 A 0 A 0 A 0 A 0 A 0
7 | A 0 A 0 A 0 A 0 A 0 A 0 A 0 A 0 A 0 A 0 A 0 A 0 A 0 A 0 A 0 A 0
   | A 0 A 0 A 0 A 0 A 0 A 0 A 0 A 0 A 0 A 0 A 0 A 0 A 0 A 0 A 0 A 0
8 | A 0 A 0 A 0 A 0 A 0 A 0 A 0 A 0 A 0 A 0 A 0 A 0 A 0 A 0 A 0 A 0
   | A 0 A 0 A 0 A 0 A 0 A 0 A 0 A 0 A 0 A 0 A 0 A 0 A 0 A 0 A 0 A 0
...
...
...
30 | A 0 A 0 A 0 A 0 A 0 A 0 A 0 A 0 A 0 A 0 A 0 A 0 A 0 A 0 A 0 A 0
    | A 0 A 0 A 0 A 0 A 0 A 0 A 0 A 0 A 0 A 0 A 0 A 0 A 0 A 0 A 0 A 0
31 | A 0 A 0 A 0 A 0 A 0 A 0 A 0 A 0 A 0 A 0 A 0 A 0 A 0 A 0 A 0 A 0
    | A 0 A 0 A 0 A 0 A 0 A 0 A 0 A 0 A 0 A 0 A 0 A 0 A 0 A 0 A 0 A 0
32 | A 0 A 0 A 0 A 0 A 0 A 0 A 0 A 0 A 0 A 0 A 0 A 0 A 0 A 0 A 0 A 0
    | A 0 A 0 A 0 A 0 A 0 A 0 A 0 A 0 A 0 A 0 A 0 A 0 A 0 A 0 A 0 A 0
```

## #savepreset Command

The #savepreset command saves the current routing and masking state to a specified preset. To restore a saved preset, use the #callpreset command (see page 57).

### Syntax:

```
#savepreset param1
```

### Parameters:

<i>param1</i>	Preset	[1 ... 16]
---------------	--------	------------

### Example:

```
#savepreset 2  
Current routing state is saved to preset
```

## #set\_input\_name Command

The #set\_input\_name command provides the specified input with a name.

### Syntax:

```
#set_input_name param1 param2
```

### Parameters:

<i>param1</i>	Input	[1 ... 32]
<i>param2</i>	Name	[20 chars max.]

### Example:

```
#set_input_name 17 signal_generator  
signal_generator is assigned to input 17
```

## **#set\_output\_name Command**

The #set\_output\_name command provides the specified output with a name.

### Syntax:

```
#set_output_name param1 param2
```

### Parameters:

<i>param1</i>	Output	[1 ... 32]
<i>param2</i>	Name	[20 chars max.]

### Example:

```
#set_output_name 25 Dell_30  
Dell_30 is assigned to output 25
```

## **#set\_preset\_name Command**

The #set\_preset\_name command provides a name for the specified preset.

### Syntax:

```
#set_preset_name param1 param2
```

### Parameters:

<i>param1</i>	Preset	[1 ... 16]
<i>param2</i>	Name	[20 chars max.]

### Example:

```
#set_preset_name 2 Studio1  
Studio1 is assigned to preset 2
```

### **#show\_input\_name Command**

The #show\_input\_name command displays the name of the specified input.

#### Syntax:

```
#show_input_name param1
```

#### Parameters:

<i>param1</i>	Input	[1 ... 32]
---------------	-------	------------

#### Notes:

If *param1* = 0, then the name of all 32 inputs will be returned.

#### Example:

```
#show_input_name 17  
Input 17 - signal_generator
```

### **#show\_output\_name Command**

The #show\_output\_name command displays the name of the specified input.

#### Syntax:

```
#show_output_name param1
```

#### Parameters:

<i>param1</i>	Input	[1 ... 32]
---------------	-------	------------

#### Notes:

If *param1* = 0, then the name of all 32 outputs will be returned.

#### Example:

```
#show_output_name 25  
Output 25 - Dell_30
```

### **#show\_preset\_name Command**

The #show\_preset\_name command displays the name of the specified preset.

#### **Syntax:**

```
#show_preset_name param1
```

#### **Parameters:**

<i>param1</i>	Preset	[1 ... 16]
---------------	--------	------------

#### **Example:**

```
#show_preset_name 2  
Preset 2 - Studio1
```

### **#unmaskout Command**

The #unmaskout command unmask the specified outputs.

#### **Syntax:**

```
#unmaskout param1 param2 ... param8
```

#### **Parameters:**

<i>param1</i>	Output	[1 ... 32]
---------------	--------	------------

#### **Notes:**

If *param1* = 0, then all outputs will be unmasked.

#### **Example:**

```
#unmaskout 4 5 8  
Unmasked Outputs: 4 5 8
```

```
#unmaskout 0  
Unmasked all Outputs
```

## m Command

The `m` command displays the current matrix status in tabular form. Do not precede this command with the “#” symbol.

### Syntax:

`m`

### Parameters:

None

### Example:

`m`

Show the matrix status in tabular form

Routing status table

Outputs	+0	+1	+2	+3	+4	+5	+6	+7
1	22	2	3	4	5	6	7	8
9	9	10	11	12	13	14	15	16
17	17	18	19	25	17	22	23	24
25	17	26	27	28	29	30	31	32

Masking status table

Outputs	+0	+1	+2	+3	+4	+5	+6	+7
1	A	A	A	A	A	A	A	A
9	A	A	A	A	A	A	A	A
17	A	A	A	A	A	A	A	A
25	A	A	A	A	A	A	A	A

Monitor HPD status table

Outputs	+0	+1	+2	+3	+4	+5	+6	+7
1	L	L	L	L	L	L	L	L
9	L	L	L	L	L	L	L	L
17	L	L	L	L	L	L	L	L
25	H	L	L	L	L	L	L	L

### **r Command**

The `r` command routes the specified input to the specified outputs. Only one input can be specified at a time. However, up to eight outputs can be specified at a time. Do not precede this command with the “#” symbol.

#### Syntax:

```
r param1 param2 ... param9
```

#### Parameters:

<i>param1</i>	Input	[1 ... 32]
<i>param2</i>	Output	[1 ... 32]

#### Notes:

If *param2* = 0, then the specified input will be routed to all outputs. The `s` command will perform this same function. See the next page for details on the `s` command.

#### Examples:

```
r 1 2 3 7 8 9  
Input 1 is routed to Outputs: 2 3 7 8 9
```

```
r 5 0  
Input 5 is routed to all Outputs
```





System Commands	
Command	Description
<code>#factory_reset</code>	Resets the matrix to factory-default settings
<code>#fadefault</code>	Resets the routing and masking to factory-default settings
<code>#fw_upgrade</code>	Used to update the 32x32 Modular Matrix firmware
<code>#help</code>	Displays a list of available RS-232 / Telnet commands
<code>#hpdto</code>	Cycles the HPD line on the specified output
<code>#lock_fo</code>	Enables / disables the power lock state
<code>#reboot</code>	Reboots the matrix
<code>#show_temp</code>	Displays the temperature of each board within the matrix
<code>#show_ver_data</code>	Displays the current hardware and firmware version
<code>#show_voltage</code>	Displays the input and output board voltages
<code>f</code>	Enables / disables the +5V on the specified input

## **#factory\_reset Command**

The `#factory_reset` command resets the matrix to factory-default settings.

### Syntax:

```
#factory_reset
```

### Parameters:

None

### Example:

```
#factory_reset
```

```
IP configuration reset to factory default
Reset to factory default, Please wait
Routing 1-1,2-2,...
Unmasked all Outputs
```

```
Loading default EDID to all locals Inputs, please wait.....
Finished Loading
```

### **#fadefault Command**

The #fadefault command resets the routing and masking to factory-default settings. This command is similar to the #factory\_reset command, except that the TCP/IP settings are preserved.

#### Syntax:

```
#fadefault
```

#### Parameters:

None

#### Example:

```
#fadefault
```

```
Reset to factory default, Please wait  
Routing 1-1,2-2,...  
Unmasked all Outputs
```

```
Loading default EDID to all locals Inputs, please wait.....  
Finished Loading
```

### **#fw\_upgrade Command**

The #fw\_upgrade command is used to update the 32x32 Modular Matrix firmware. See page 98 for details on using this command.

#### Syntax:

```
#fw_upgrade
```

#### Parameters:

None

#### Example:

See page 98.





## #reboot Command

The #reboot command reboots the matrix. This is the equivalent of physically disconnecting and reconnecting the AC power cord to the matrix. *param1* must be included as part of the command at all times.

### Syntax:

```
#reboot param1
```

### Parameters:

<i>param1</i>	Constant	10
---------------	----------	----

### Example:

```
#reboot 10
```

The system will reboot itself, please wait

```
*****
```

```
GEFEN  
Modular MultiMatrix  
UI FW version: 0.3.38
```

```
*****
```

```
Establish connection with Input Board 1
```

```
Board Type: DP input 8 channels  
Board SN: 959793  
FW ver:0.3.8
```

```
Establish connection with Input Board 2
```

```
Board Type: DP input 8 channels  
Board SN: 959800  
FW ver:0.3.8
```

```
Establish connection with Input Board 3
```

```
Board Type: DVI input 8 channels  
Board SN: 954849  
FW ver:0.3.8
```

```
...
```

```
...
```

```
Establish connection with BP Board
```

```
Board Type: BP 32  
Board SN: 953703  
FW ver:0.3.43
```

```
Init Routing, Please wait
```

```
.....
```

```
Loading Downstream EDID 25 to all locals Inputs, please  
wait.....
```

```
Finished Loading
```

### **#show\_temp Command**

The #show\_temp command displays the temperature of each board within the matrix.

#### Syntax:

```
#show_temp
```

#### Parameters:

None

#### Example:

```
#show_temp
Temperature result [C deg] for UI board:34
Temperature result [C deg] for BP board
sensor1 (Mindspeed) - 47
sensor2 (power)      - 39
Temperature result [C deg] for Inputs board
Board| 1 | 2
      1|42 |34
      2|39 |33
      3|38 |33
      4|37 |35
Temperature result [C deg] for Outputs board
Board| 1 | 2
      1|51 |43
      2|53 |38
      3|52 |38
      4|47 |39
```

### **#show\_ver\_data Command**

The #show\_ver\_data command displays the current hardware and firmware version.

#### Syntax:

```
#show_ver_data
```

#### Parameters:

None

#### Example:

```
#show_ver_data
Firmware Release version 0.3.38
Release date: Nov 20 2012
Release time: 15:00:38
```

## **#show\_voltage Command**

The #show\_voltage command displays the input and output board voltages.

### **Syntax:**

```
#show_voltage
```

### **Parameters:**

None

### **Example:**

```
#show_voltage
ADC UI measurement result:
VCC CORE 1.8, Value = 1845 mVolt
PSU1 - DS460
PSU1 PSOK, Value = 1038 mVolt
PSU1 Imon, Value = 519 mV -> 5 A
PSU2 - DS460
PSU2 PSOK, Value = 2625 mVolt
PSU2 Imon, Value = 496 mV -> 5 A
Power result [mV] for all boards:
Power result [mV] for BP board
5V |3.3V|1.2V|1.2V
5056|3326|1212|1210
Power result [mV] for Inputs board
Board|3.3/5|1.2/3.3|1.8V
  1| 3290|   1201|0
  2| 3398|   1204|0
  3| 5126|   3388|1810
  4| 5080|   3342|1807
Power result [mV] for Outputs board
Board|1/5 |3.3   |1.8V
  1| 5072|   3282|1807
  2| 1009|   3342|1815
  3| 1012|   3350|1823
  4| 5078|   3302|1793
```

## f Command

The `f` command enables / disables the +5V on the specified input.



**WARNING:** Use caution when applying power to inputs. If the source device supplies +5V on the input, then enabling the +5V may cause damage to the source and/or the 32x32 Modular Matrix.

### Syntax:

```
f param1 param2
```

### Parameters:

*param1* Input [1 ... 32]

*param2* State [0 ... 1]

Value	Meaning
0	Disable
1	Enable

### Example:

```
f 15 1
```



## Using the Built-in Web server

The Web GUI is divided into four main pages: **Routing**, **Status**, **Manage EDID**, and **Configuration**. Each of these pages is represented by a tab. Click on the desired tab to open its page. Each page also has its own set of tabs which can be accessed. When the Web GUI is opened, the **Routing** page / tab will be displayed.

### Routing >> Routing

#### Tabs

Click a tab to open the desired page.

The screenshot shows the GefenPRO web interface for a 32x32 Modular Matrix. The top navigation bar includes tabs for Routing, Status, Manage EDID, and Configuration. Below this, a secondary navigation bar contains tabs for Routing, Preset Names, I/O Names, and +5V. The main content area displays a 'LOCK Matrix' button and a 'STATUS' table. A callout box highlights the 'LOCK Matrix' button and the 'STATUS' table.

STATUS		
Output	Input	HPD
1	22	Off
2	2	Off
3	3	Off
4	4	Off
5	5	Off
6	6	Off

#### LOCK Matrix

Locks / unlocks the matrix. When the Matrix is locked, no modifications can be made using the Web GUI.

#### Output

The port number of the output. The blue highlight indicates that the output has been masked. See page 83 for more information on masking outputs.

#### Input

Displays the input that has been routed to the output. In the illustration above, Input 22 has been routed to Output 1.

#### HPD

Indicates the Hot Plug Detect (HPD) status of the input.

## OUTPUTS

Provides information on each Output on the matrix.

OUTPUTS		
Type	Output #	Name
FOPT_OUT	1 <input type="checkbox"/>	Output_1
	2 <input type="checkbox"/>	Output_2
	3 <input type="checkbox"/>	Output_3
	4 <input type="checkbox"/>	Output_4
	5 <input type="checkbox"/>	Output_5
	6 <input type="checkbox"/>	Output_6
	7 <input type="checkbox"/>	Output_7
	8 <input type="checkbox"/>	Output_8
ELR_OUT	9 <input type="checkbox"/>	Output_9
	10 <input type="checkbox"/>	Output_10
	11 <input type="checkbox"/>	Output_11
	12 <input type="checkbox"/>	Output_12
	13 <input type="checkbox"/>	Output_13
	14 <input type="checkbox"/>	Output_14

Check All    Clear All

### Type

Displays the type of output card used in slot.

FOPT\_OUT: Modular Matrix 8 DVI Sender over 1FO (GEF-DVI-8FO-S)

ELR\_OUT: Modular Matrix 8 DVI Sender over CAT-5 Card (GEF-DVI-8ELR-S)

DVI\_OUT: Modular Matrix 8 DVI Output Card (GEF-MOD-8DVI-O)

### Output #

Click to place a check mark in the box and select the desired output.

Multiple outputs can be selected at a time.

### Name

Displays the current name of the output. The name of each output can be changed. See page 80 for details.

## INPUTS

Provides information on each Input on the matrix.

INPUTS		
Name	Input #	Type
Input_1	<input type="radio"/> 1	DP_IN
Input_2	<input type="radio"/> 2	
Input_3	<input type="radio"/> 3	
Input_4	<input type="radio"/> 4	
Input_5	<input type="radio"/> 5	
Input_6	<input type="radio"/> 6	
Input_7	<input type="radio"/> 7	
Input_8	<input type="radio"/> 8	
Input_9	<input type="radio"/> 9	DP_IN
Input_10	<input type="radio"/> 10	
Input_11	<input type="radio"/> 11	
Input_12	<input type="radio"/> 12	
Input_13	<input type="radio"/> 13	
Input_14	<input type="radio"/> 14	

**Route**

Click this button to route the current input and output selection(s).

### Name

Displays the current name of the input. The name of each input can be changed. See page 80 for details.

### Input #

Click the radio button next to the desired input to be routed. Only one input can be selected at a time.

### Type

Displays the type of input card used in slot.

DVI\_IN: Modular Matrix 8 DVI Input Card (GEF-MOD-8DVI-I)

DP\_OUT: Modular Matrix 8 DisplayPort Card (GEF-MOD-8DP-I)

# RS-232 / IP / UDP CONTROL

## Legend

Provides color-coded information on the status of each Input and Output.

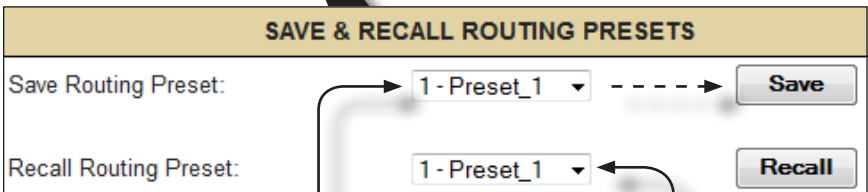
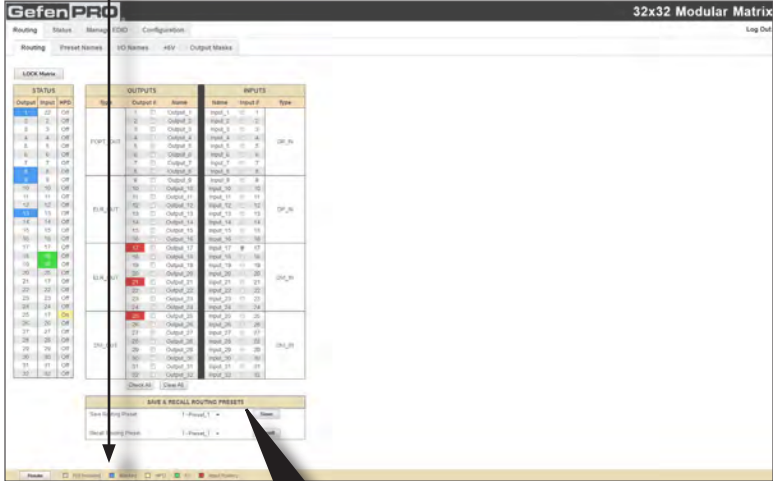
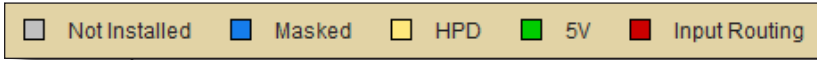

### Save Routing Preset

Saves the current routing state to memory. Click the drop-down list to select the desired routing preset, then click the **Save** button to save the preset to memory.

### Recall Routing Preset

Loads the selected routing state into memory. Click the drop-down list to select the desired routing preset, then click the **Recall** button to load the preset into memory.

## Routing >> Preset Names

### Refresh

Updates the Web page to reflect the new Preset Name.

The screenshot shows the 'Gefen PRO' web interface with the '32x32 Modular Matrix' configuration page. The 'Preset Names' tab is active. A dialog box titled 'EDIT PRESET NAMES' is open, displaying a table with 7 rows. The first row is highlighted, and an arrow points from the 'Name' column to the text below. The dialog also features a 'Refresh' button at the top and 'Save Changes' and 'Cancel' buttons at the bottom. A box highlights the 'Save Changes' and 'Cancel' buttons.

Preset #	Name
1	Preset_1
2	Preset_2
3	Preset_3
4	Preset_4
5	Preset_5
6	Preset_6
7	Preset_7

### Name

Type the desired name of the Preset in this field. Click the Save Changes button to save the Preset Name. Click the Cancel button to restore the previous name.

### Save Changes

Saves the current changes.

### Cancel

Restores the previous names for each Preset, if a change was made.

## Routing >> I/O Names

### Refresh

Updates the Web page to reflect the new Input and/or Output Name.

**Refresh**

**EDIT OUTPUT**

Output #	Name
1	Output_1
2	Output_2
3	Output_3
4	Output_4
5	Output_5

**INPUT NAMES**

Input #	Name
1	Input_1
2	Input_2
3	Input_3
4	Input_4
5	Input_5
6	Input_6
7	Input_7

**Save Changes**      **Cancel**

### Save Changes

Saves the current changes.

### Cancel

Restores the previous names for each Input and/or Output, if a change was made.

## Routing >> +5V



**WARNING:** Use caution when applying power to inputs. If the source device supplies +5V on the input, then enabling the +5V may cause damage to the source and/or the 32x32 Modular Matrix.

### Refresh

Updates the Web page to reflect the new Input and/or Output Name.

Refresh

### LOCK Power

Enables/disables the power lock state. See the RS-232 command #lock\_fo command on page 70 for more information.

LOCK Power

+5 VOLT		
Input #	Name	+5 V
1	Input_1	<input type="checkbox"/>
2	Input_2	<input type="checkbox"/>
3	Input_3	<input type="checkbox"/>
4	Input_4	<input type="checkbox"/>
5	Input_5	<input type="checkbox"/>
6	Input_6	<input type="checkbox"/>
7	Input_7	<input type="checkbox"/>
8	Input_8	<input type="checkbox"/>
9	Input_9	<input type="checkbox"/>
10	Input_10	<input type="checkbox"/>
11	Input_11	<input type="checkbox"/>

### Input #

Indicates the number of each Input. If the input has +5V enabled, it will be highlighted in green (as shown).

### Name

The current name of each input.

### +5V

Click to select the desired Input(s). Selecting an input does *not* automatically enable the +5V. Use the **Set** button to enable the +5V.

16	Input_16	<input type="checkbox"/>
17	Input_17	<input type="checkbox"/>
18	Input_18	<input checked="" type="checkbox"/>
19	Input_19	<input checked="" type="checkbox"/>
20	Input_20	<input type="checkbox"/>
21	Input_21	<input type="checkbox"/>
22	Input_22	<input type="checkbox"/>

# RS-232 / IP / UDP CONTROL

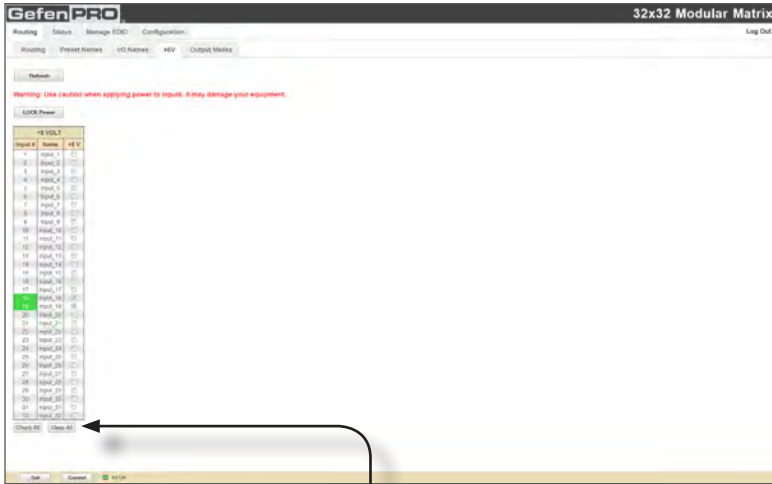

Check All

Clear All

### Check All

Places a check mark in each box under the +5V column.

### Clear All

Clears all check marks from the +5V column.

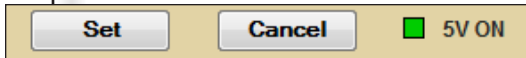

### Set

Click this button to enable +5V on the selected input(s). See the previous page for information on selecting inputs.

### Cancel

Restores the previous +5V state for each input, if a change was made.

### 5V ON (legend)

If +5V has been enabled on any of the inputs, these inputs will be highlighted in green. See the previous page for more information.



## Routing >> Output Masks

### Refresh

Updates the Web page to reflect the new Input and/or Output Name.

Refresh

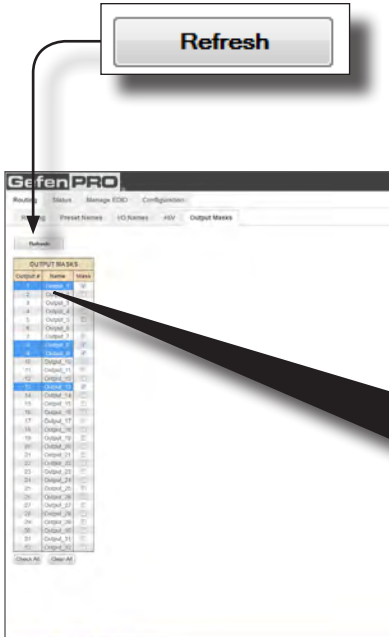

OUTPUT MASKS		
Output #	Name	Mask
1	Output_1	<input checked="" type="checkbox"/>
2	Output_2	<input type="checkbox"/>
3	Output_3	<input type="checkbox"/>
4	Output_4	<input type="checkbox"/>
5	Output_5	<input type="checkbox"/>
6	Output_6	<input type="checkbox"/>
7	Output_7	<input type="checkbox"/>
8	Output_8	<input checked="" type="checkbox"/>
9	Output_9	<input checked="" type="checkbox"/>
10	Output_10	<input type="checkbox"/>
11	Output_11	<input type="checkbox"/>
12	Output_12	<input type="checkbox"/>
13	Output_13	<input checked="" type="checkbox"/>
14	Output_14	<input type="checkbox"/>
15	Output_15	<input type="checkbox"/>
16	Output_16	<input type="checkbox"/>
17	Output_17	<input type="checkbox"/>
18	Output_18	<input type="checkbox"/>
19	Output_19	<input type="checkbox"/>
20	Output_20	<input type="checkbox"/>
21	Output_21	<input type="checkbox"/>
22	Output_22	<input type="checkbox"/>
23	Output_23	<input type="checkbox"/>
24	Output_24	<input type="checkbox"/>
25	Output_25	<input type="checkbox"/>
26	Output_26	<input type="checkbox"/>
27	Output_27	<input type="checkbox"/>

**Output #**  
Indicates the number of each output. If the output has been masked, it will be highlighted in blue (as shown).

**Name**  
The current name of each output.

**Mask**  
Click to select the desired Output(s) to be masked. Selecting an output does *not* automatically enable masking. The **Set** button must be used to enable masking. To disable masking, deselect the desired outputs and press the **Set** button.

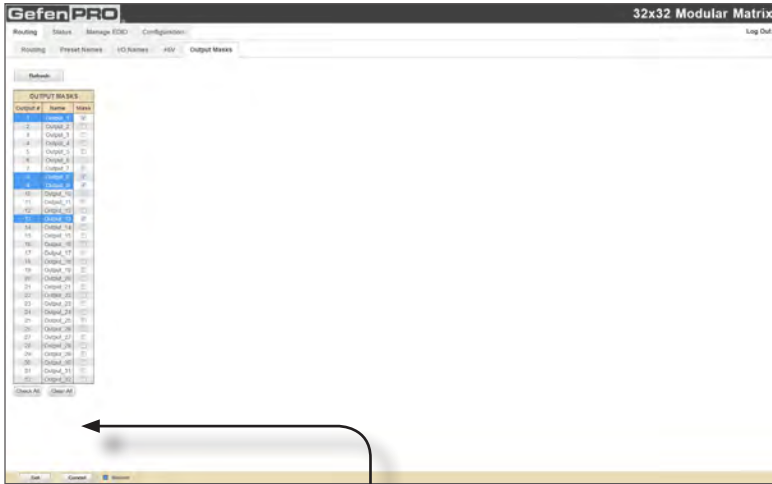

**Check All**

Places a check mark in each box under the **Mask** column.

**Clear All**

Clears all check marks from the **Mask** column.

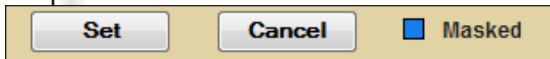

**Set**

Click this button to enable masking on the selected output(s). See the previous page for information on selecting inputs.

**Cancel**

Restores the previous masking state for each output, if a change was made.

**Masked (legend)**

If masking has been enabled on any of the outputs, then these outputs will be highlighted in blue.

## Status >> In/Out

The **Status >> In/Out** tab provides information on the hardware and firmware of the 32x32 Modular Matrix. The **OUTPUTS** column lists each Output Card that is installed. The **INPUTS** column lists each Input Card that is installed.

The information presented on this screen is used by Gefen Technical Support for troubleshooting purposes, only.



HARDWARE			
OUTPUTS		INPUTS	
A		A	
S/N	981708	S/N	959793
Type	FOPT_OUT	Type	DP_IN
F/W Ver	0.03.08	F/W Ver	0.03.08
Temp1	49 C deg	Temp1	40 C deg
Temp2	41 C deg	Temp2	32 C deg
Connection	1	Connection	1
Power 3.3v	3282 mv	Power 3.3v	1207 mv
Power 5.0v	5064 mv	Power 5.0v	3360 mv
Power 1.8v	1806 mv	Power 1.8v	0 mv
B		B	
S/N	981809	S/N	959800
Type	ELR_OUT	Type	DP_IN
F/W Ver	0.03.08	F/W Ver	0.03.08
Temp1	50 C deg	Temp1	37 C deg
Temp2	35 C deg	Temp2	30 C deg
Connection	1	Connection	1
Power 3.3v	3334 mv	Power 3.3v	1204 mv
Power 5.0v	1008 mv	Power 5.0v	3400 mv
Power 1.8v	1814 mv	Power 1.8v	0 mv
C		C	

## Status >> System

The **Status >> System** tab provides additional detailed information on the 32x32 Modular Matrix hardware. The information presented on this screen is used by Gefen Technical Support for troubleshooting purposes, only.

BACKPLANE	
S/N	953703
F/W Ver	0.03.43
MSTemp	44 C deg
PTemp	36 C deg
Power 3.3v	3326 mv
Power 5.0v	5042 mv
Core Power	1211 mv
IO Power	1211 mv
Fans1	OFF
Fans2	OFF
Fans3	OFF
CONTROL BOARD	
S/N	953540
F/W Ver	0.03.38
Temp	31 C deg
Power	1848 mv
PSU1	1074 mv
PSU2	2612 mv
Serial	RS232

## Manage EDID >> Assign

### EDID Lock

Secures the Local EDID and disables the automatic loading after power-up. See the #lock\_edid command on page 42 for more information.

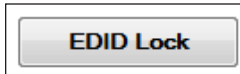

### Copy EDID From

Select the EDID from the drop-down list. The EDID will be copied from the selected destination to the desired input(s).

Options:  
Default EDID,  
Bank\_1 ... Bank\_20,  
Output\_1 ... Output\_32

### Copy EDID From

Default EDID

The screenshot shows the 'Manage EDID' window in GefenPRO. The 'EDID Lock' checkbox is checked. The 'Copy EDID From' dropdown menu is set to 'Default EDID'. Below this is a table with columns for 'Input #', 'EDID Source', and 'EDID Name'. The table lists 32 inputs, each with a corresponding EDID source and name. At the bottom of the table are 'Check All' and 'Clear All' buttons. The 'Copy' and 'Cancel' buttons are located at the bottom of the window.

Input #	EDID Source	EDID Name
1	input_1	Output 01
2	input_2	Output 02
3	input_3	Output 03
4	input_4	Output 04
5	input_5	Output 05
6	input_6	Output 06
7	input_7	Output 07
8	input_8	Output 08
9	input_9	Output 09
10	input_10	Output 10
11	input_11	Output 11
12	input_12	Output 12
13	input_13	Output 13
14	input_14	Output 14
15	input_15	Output 15
16	input_16	Output 16
17	input_17	Output 17
18	input_18	Output 18
19	input_19	Output 19
20	input_20	Output 20
21	input_21	Output 21
22	input_22	Output 22
23	input_23	Output 23
24	input_24	Output 24
25	input_25	Output 25
26	input_26	Output 26
27	input_27	Output 27
28	input_28	Output 28
29	input_29	Output 29
30	input_30	Output 30
31	input_31	Output 31
32	input_32	Output 32

### Check All

Places a check mark in all boxes.

Check All

Clear All

### Clear All

Clears all check marks from each box.

### Copy

Copies the EDID source to the selected input(s).

### Cancel

Clears all check marks from each box.

The screenshot shows the GefenPRO 32x32 Modular Matrix configuration interface. On the left, a table lists EDID sources with columns for Input #, Name, EDID Source, and EDID Name. On the right, a larger table summarizes the inputs, with columns for Input #, Name, and a checkbox. A callout box highlights the checkbox for Input 1.

Input #	Name	
1	Input_1	<input type="checkbox"/>
2	Input_2	<input type="checkbox"/>
3	Input_3	<input type="checkbox"/>
4	Input_4	<input type="checkbox"/>
5	Input_5	<input type="checkbox"/>
6	Input_6	<input type="checkbox"/>
7	Input_7	<input type="checkbox"/>
8	Input_8	<input type="checkbox"/>
9	Input_9	<input type="checkbox"/>
10	Input_10	<input type="checkbox"/>
11	Input_11	<input type="checkbox"/>
12	Input_12	<input type="checkbox"/>
13	Input_13	<input type="checkbox"/>
14	Input_14	<input type="checkbox"/>
15	Input_15	<input type="checkbox"/>
16	Input_16	<input type="checkbox"/>
17	Input_17	<input type="checkbox"/>
18	Input_18	<input type="checkbox"/>
19	Input_19	<input type="checkbox"/>
20	Input_20	<input type="checkbox"/>
21	Input_21	<input type="checkbox"/>
22	Input_22	<input type="checkbox"/>
23	Input_23	<input type="checkbox"/>
24	Input_24	<input type="checkbox"/>
25	Input_25	<input type="checkbox"/>
26	Input_26	<input type="checkbox"/>
27	Input_27	<input type="checkbox"/>
28	Input_28	<input type="checkbox"/>
29	Input_29	<input type="checkbox"/>
30	Input_30	<input type="checkbox"/>
31	Input_31	<input type="checkbox"/>
32	Input_32	<input type="checkbox"/>

INPUTS	
EDID Source	EDID Name
Output 25	
Output 25	
Output 25	
Output 25	
Output 25	
Output 25	
Output 25	
Output 25	
Output 25	

**EDID Source**  
Displays the EDID source used by the input. In the illustration above, the EDID source is Output 25.

**EDID Name**  
Displays the name of the EDID.

**Checkbox**  
Click to select the Input(s) to where the EDID source will be copied. Selecting an input does *not* automatically copy the EDID source. Click the **Copy** button to copy the EDID to the input.

**Input #**  
Indicates the number of each input.

**Name**  
The current name assigned to each input.

## Manage EDID >> Bank Names

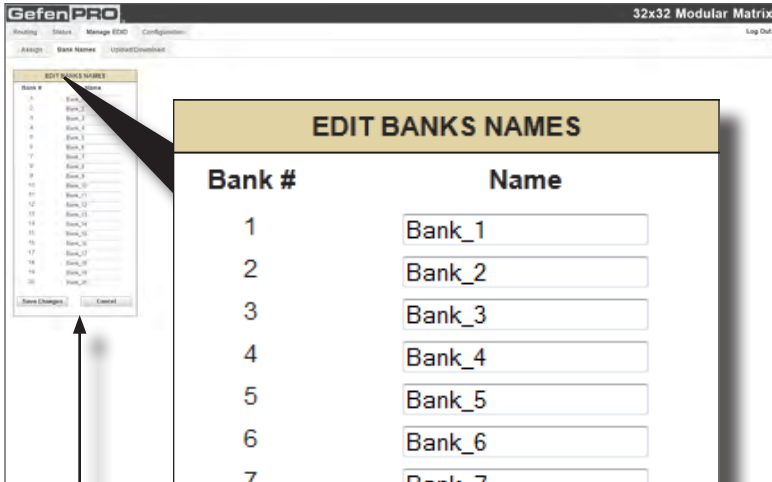

### Bank #

Indicates the EDID bank number.

### Name

Type the desired name of the EDID bank in this field.  
Click the **Save Changes** button to save the bank name.  
Click the **Cancel** button to restore the previous name.



### Save Changes

Saves the current name change to the EDID bank(s).

### Cancel

Restores the previous names for each EDID bank, if a change was made.

## Manage EDID >> Upload/Download

**UPLOAD EDID**

Select EDID File to Upload:

Select Bank Location:  
-- Select Bank --

**DOWNLOAD EDID**

-- SAVED EDIDS --

### Upload

Click this button to upload the EDID to the specified bank.

### Select Bank Location

Click this drop-down list to select the bank to where the EDID will be uploaded.

Options:

Bank\_1 ... Bank\_20

### Download

Click this button to download the selected EDID to a file.

### Browse...

Click this button to select the EDID file to be uploaded.

### Drop-down list

Click this box to select the EDID that is to be saved to a file. The EDID file will be saved in binary format (.bin).

Options:

Bank\_1 ... Bank\_20,  
Output\_1 ... Output\_32,  
Input\_1 ... Input\_32



## Configuration

### CHANGE IP SETTINGS

Assigns IP address, subnet, gateway, HTTP listening port, Telnet port, and UDP port. The MAC address cannot be changed.

Click the **Save Settings** button to apply changes. Click the Set Defaults button to restore the factory-default IP settings. The 32x32 Modular Matrix must be rebooted for any changes to take effect.

CHANGE IP SETTINGS	
MAC Address:	00:1C:91:02:80:2B
IP Address:	<input type="text" value="192.168.1.205"/>
Subnet:	<input type="text" value="255.255.255.0"/>
Gateway:	<input type="text" value="192.168.1.1"/>
HTTP Port:	<input type="text" value="80"/>
TCP/Telnet Terminal Port:	<input type="text" value="23"/>
UDP Port:	<input type="text" value="21"/>
<input type="button" value="Save Settings"/> <input type="button" value="Set Defaults"/>	

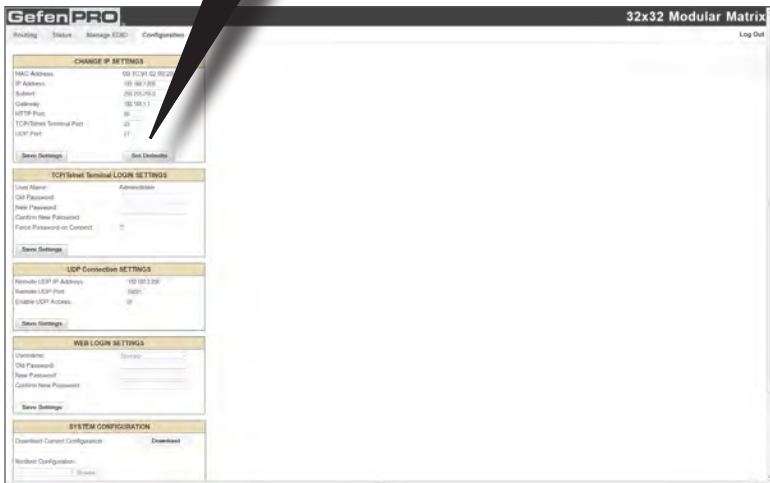

## TCP/Telnet Terminal LOGIN SETTINGS

Sets the user name and password for Telnet sessions to the 32x32 Modular Matrix. Click the **Save Settings** button to apply changes.

Click the **Force Password on Connect** check box to have the 32x32 Modular Matrix prompt for a password each time a Telnet session is started.

### TCP/Telnet Terminal LOGIN SETTINGS

User Name:	Administrator
Old Password:	<input type="text"/>
New Password:	<input type="text"/>
Confirm New Password:	<input type="text"/>
Force Password on Connect:	<input type="checkbox"/>

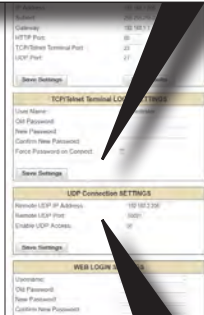

### UDP Connection SETTINGS

Remote UDP IP Address:	192.168.2.206
Remote UDP Port:	50021
Enable UDP Access:	<input checked="" type="checkbox"/>

## UDP Connection SETTINGS

Sets the remote UDP IP Address and Port. Click the **Save Settings** button to apply changes.

Click the **Enable UDP Access** check box to...

## WEB LOGIN SETTINGS

Sets the user name and password for Web Interface sessions using the 32x32 Modular Matrix. Click the **Save Settings** button to apply changes.

### WEB LOGIN SETTINGS

Username:

Old Password:

New Password:

Confirm New Password:



### SYSTEM CONFIGURATION

Download Current Configuration

Restore Configuration

*Warning: All current settings will be lost*

### SYSTEM CONFIGURATION

Allows saving and loading of configuration files. This feature allows the current state of the 32x32 Modular Matrix to be saved as a file. This file can then be used to restore any previous configuration changes.

**Restore**  
Uploads the selected configuration file to the 32x32 Modular Matrix.

**Download**  
Click this button to download the current configuration to a file.



**NOTE:** As of this writing, the firmware update procedure is not functional from within the Web interface. This feature will be available in a future release of the product. The firmware update procedure must be performed using RS-232. See page 98.

### Browse...

*(future implementation)*  
Selects the firmware file to be used to upgrade the 32x32 Modular Matrix.

### Update

*(future implementation)*  
Updates the 32x32 Modular Matrix with the selected firmware file.

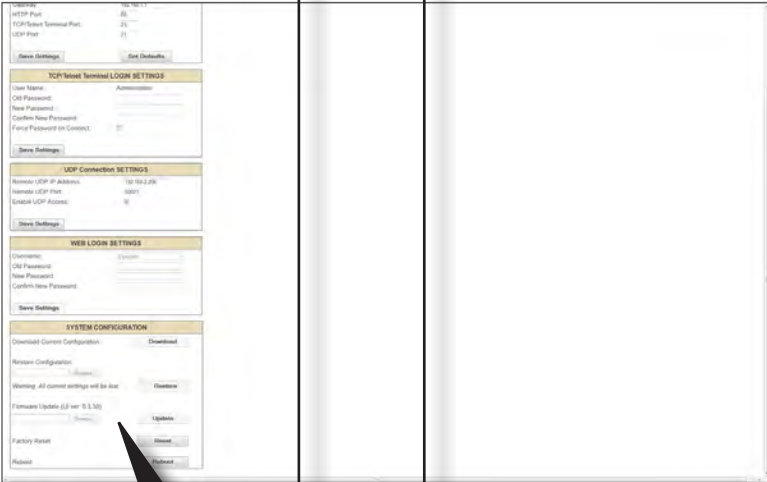

### Firmware Update (UI ver: 0.3.38)

### Factory Reset

### Reboot

### Reset

Click this button to set the 32x32 Modular Matrix. to factory-default settings.

### Reboot

Click this button to reboot the 32x32 Modular Matrix.

## Card Removal and Installation

Although each *32x32 Modular Matrix* is sold pre-configured, both input and output cards can be removed or added to fit the needs of the application. Each module can easily be removed and installed without using any special tools.



**IMPORTANT:** Modules are sensitive to Electrostatic Discharge (ESD) which can damage the module. Avoid touching the module contacts or the components on the module. Always hold modules by the edges or by the knobs on the front of the module. Never slide a module over any surface. When installing/replacing modules, do not install an input module in to an output slot (or vice versa). This will damage the matrix and void the warranty.

1. Power-off the matrix.
2. Turn the matrix around so that you are facing the back of the unit.



**STOP:** Before installing modules and prevent the risk of possible electrical shock, unplug the AC power cord from back of the matrix.

3. Loosen the fastening screws on both sides of the card (or cover plate) to be removed. Each card / cover plate has two fastening screws.



## APPENDIX

- Grab the knobs on both sides of the card, between the thumb and index finger, and gently pull to remove the card from the matrix, as shown on the next page. If a cover plate is being removed, then loosen the fastening screws on both sides of the cover plate and gently remove the cover plate.



- Locate the grooved metal track on either side of the expansion bay.

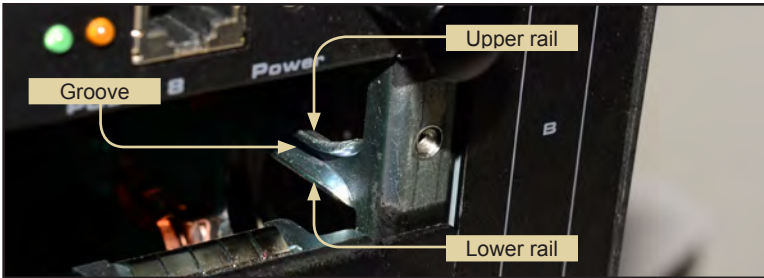

- Carefully position the card between the upper and lower rail on each track and slowly push the card forward.

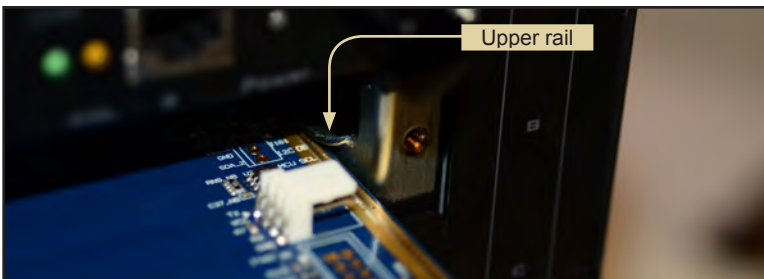

## APPENDIX

7. Position either hand on both sides of the matrix and firmly push the card with both thumbs until it snaps in place.



8. Secure the card by hand-tightening the fastening screws. Do not overtighten the screws. To prevent damage to the screws, do not use pliers or other high-torque devices.



## Firmware Update Procedure

The following items are required to update firmware:

- GefenPRO 32x32 Modular Matrix
- Computer running Windows XP
- Terminal-emulation program (e.g. HyperTerminal)
- RS-232 cable (do not use a null-modem cable)
- Firmware files: MMTX\_BP\_[version].bin,  
MMTX\_DVInout\_[version].bin,  
MMTX\_UI\_[version].bin

To begin the update procedure use the #fw\_update command. The following set of instructions will be using Hyperterminal.

1. Power-on the matrix.
2. Connect an RS-232 cable to the PC and open the terminal program using the following settings:

```
Baud rate:    19200
Stop bits:    1
Data bits:    8
Flow control: None
```

3. Type the command: #fw\_update.
4. The following will be displayed on the terminal screen:

```
=====
Download new FW_____1
cancel_____0
=====
```

5. Press the '1' on the computer keyboard to select Download new FW.

The following will be displayed:

```
Please send new FW bin file
Waiting for the file to be sent ... (press 'a' to abort)
```

6. In HyperTerminal, click Transfer --> Send File...
7. Select the firmware file: MMTX\_BP\_e\_[version].bin
8. Select YModem from the Protocol drop-down list.
9. Click the OK button.



## APPENDIX

---

The firmware update procedure will begin. This process should take a couple of minutes and will update the back panel boards. After the firmware update is successful, the following will be displayed in the terminal program:

```
Verify Check sum, please wait

Download Completed Successfully!
MMTX_BP_e_0_3_43.bin
  Size: 50688      Bytes
Activate boot loader for BP board
Please wait.....The system will reboot itself, please
wait
..
*****
GEFEN
Modular MultiMatrix
UI FW version: 0.3.38
*****

Establish connection with Input Board 1
  Board Type: DP input 8 channels
  Board SN: 959800
  FW ver:0.3.8
Establish connection with Input Board 2
  Board Type: DP input 8 channels
  Board SN: 959793
  FW ver:0.3.8
Establish connection with Input Board 3
  Board Type: DVI input 8 channels
  Board SN: 954849
  FW ver:0.3.8
Establish connection with Input Board 4
  Board Type: DVI input 8 channels
  Board SN: 954759
  FW ver:0.3.8
Establish connection with Output Board 1
  Board Type: FO output 8 channels
  Board SN: 981708
  FW ver:0.3.8
  ...
  ...
  ...
Establish connection with BP Board
  Board Type: BP 32
  Board SN: 953703
  FW ver:0.3.43

Init Routing, Please wait
.....
Loading default EDID to all locals Inputs, please wait.....
Finished Loading
```

## APPENDIX

10. Repeat steps 3 through 9 using the `MMTX_DVIinout_[version].bin` file. The update process for the Input / Output boards may take several minutes. After the update process is complete, the following will be displayed in the terminal window:

```
Verify Check sum, please wait

Download Completed Successfully!
MMTX_DVIinout_e_0_3_8.bin
Size: 68640 Bytes
Activate boot loader for all IN/OUT boards
Please wait.....
.....
.....
.....
.....
Finished loading new FW version to all IN/OUT boards
The system will reboot itself, please wait

*****
GEFEN
Modular MultiMatrix
UI FW version: 0.3.38
*****

Establish connection with Input Board 1
Board Type: DP input 8 channels
Board SN: 959800
FW ver:0.3.8
Establish connection with Input Board 2
Board Type: DP input 8 channels
Board SN: 959793
FW ver:0.3.8
Establish connection with Input Board 3
Board Type: DVI input 8 channels
Board SN: 954849
...
...
...

Establish connection with BP Board
Board Type: BP 32
Board SN: 953703
FW ver:0.3.43

Init Routing, Please wait
.....
Loading default EDID to all locals Inputs, please wait.....
Finished Loading
```

11. Finally, repeat steps 3 through 9 using the `MMTX_UI_[version].bin` file. This file updates the Web UI. This file is relatively large and this process may take several minutes. After the update process is complete, the following will be displayed in the terminal window:

```
Verify Check sum, please wait

Download Completed Successfully!
MMTX_UI_e_0_3_38.bin
  Size: 498240      Bytes
Activate boot loader for UI board
Please wait...
=====
==          Gefen MMTX Boot Loader          ==
==                  v 3.7                  ==
=====

Checking program CS in SPI flash, Please wait
.....
Erasing internal FLASH, please wait ...
Writing internal FLASH, please wait .....
.....
Download Completed Successfully!

*****
GEFEN
Modular MultiMatrix
UI FW version: 0.3.38
*****

Establish connection with Input Board 1
  Board Type: DP input 8 channels
  Board SN: 959800
  FW ver:0.3.8
Establish connection with Input Board 2
  Board Type: DP input 8 channels
  Board SN: 959793
      ...
      ...
Establish connection with BP Board
  Board Type: BP 32
  Board SN: 953703
  FW ver:0.3.43

Init Routing, Please wait
.....
Loading default EDID to all locals Inputs, please wait.....
Finished Loading
```

12. The firmware update process is complete.

## RACK MOUNT SAFETY INFORMATION

---

- a. Maximum recommended ambient temperature: 45 °C (104 °F).
- b. Increase the air flow as needed to maintain the recommended temperature inside the rack.
- c. Do not exceed maximum weight loads for the rack. Install heavier equipment in the lower part of the rack to maintain stability.
- d. Consideration should be given to the connection of the equipment to the supply circuit and the effect that overloading of circuits might have on overcurrent protection and supply wiring.
- e. Connect a bonding wire between an approved safety ground and the grounding screw on the chassis.

## SPECIFICATIONS

---

Maximum Pixel Clock..... 165 MHz

Input Video Signal..... 1.2V p-p

DVI Input Connectors.....(32), organized into banks of 8  
depending upon the type of input card used:

- DVI: (8) DVI-I, 29-pin, female
- DisplayPort: (8) female

Output Connectors..... (32), organized into banks of 8  
depending upon the type of output card used:

- DVI: (8) DVI-I, 29-pin, female
- ELR: (8) RJ-45
- Fiber: (8) SC

RS-232 serial port..... DB-9, female

Ethernet (IP control) port..... RJ-45 jack (100BaseT)

Power Supplies..... (2) 100 - 240V AC (dual IEC hot-swappable)

Rack-Mountable..... 6U rack height, rack ears included

Dimensions (W x H x D)..... 17.6" x 10.5" x 19" D (447mm x 266mm x 482mm )

Shipping Weight..... 44 bs. (20 kg)

## WARRANTY

---

Gefen warrants the equipment it manufactures to be free from defects in material and workmanship.

If equipment fails because of such defects and Gefen is notified within two (2) years from the date of shipment, Gefen will, at its option, repair or replace the equipment, provided that the equipment has not been subjected to mechanical, electrical, or other abuse or modifications. Equipment that fails under conditions other than those covered will be repaired at the current price of parts and labor in effect at the time of repair. Such repairs are warranted for ninety (90) days from the day of reshipment to the Buyer.

This warranty is in lieu of all other warranties expressed or implied, including without limitation, any implied warranty or merchantability or fitness for any particular purpose, all of which are expressly disclaimed.

1. Proof of sale may be required in order to claim warranty.
2. Customers outside the US are responsible for shipping charges to and from Gefen.
3. Copper cables are limited to a 30 day warranty and cables must be in their original condition.

The information in this manual has been carefully checked and is believed to be accurate. However, Gefen assumes no responsibility for any inaccuracies that may be contained in this manual. In no event will Gefen be liable for direct, indirect, special, incidental, or consequential damages resulting from any defect or omission in this manual, even if advised of the possibility of such damages. The technical information contained herein regarding the features and specifications is subject to change without notice.

For the latest warranty coverage information, refer to the Warranty and Return Policy under the Support section of the Gefen Web site at [www.gefen.com](http://www.gefen.com).

### PRODUCT REGISTRATION

**Please register your product online by visiting the Register Product page under the Support section of the Gefen Web site.**

## LICENSING

---

lwIP is licenced under the BSD licence:

Copyright (c) 2001-2004 Swedish Institute of Computer Science. All rights reserved.

Redistribution and use in source and binary forms, with or without modification, are permitted provided that the following conditions are met:

1. Redistributions of source code must retain the above copyright notice, this list of conditions and the following disclaimer.
2. Redistributions in binary form must reproduce the above copyright notice, this list of conditions and the following disclaimer in the documentation and/or other materials provided with the distribution.
3. The name of the author may not be used to endorse or promote products derived from this software without specific prior written permission.

THIS SOFTWARE IS PROVIDED BY THE AUTHOR "AS IS" AND ANY EXPRESS OR IMPLIED WARRANTIES, INCLUDING, BUT NOT LIMITED TO, THE IMPLIED WARRANTIES OF MERCHANTABILITY AND FITNESS FOR A PARTICULAR PURPOSE ARE DISCLAIMED. IN NO EVENT SHALL THE AUTHOR BE LIABLE FOR ANY DIRECT, INDIRECT, INCIDENTAL, SPECIAL, EXEMPLARY, OR CONSEQUENTIAL DAMAGES (INCLUDING, BUT NOT LIMITED TO, PROCUREMENT OF SUBSTITUTE GOODS OR SERVICES; LOSS OF USE, DATA, OR PROFITS; OR BUSINESS INTERRUPTION) HOWEVER CAUSED AND ON ANY THEORY OF LIABILITY, WHETHER IN CONTRACT, STRICT LIABILITY, OR TORT (INCLUDING NEGLIGENCE OR OTHERWISE) ARISING IN ANY WAY OUT OF THE USE OF THIS SOFTWARE, EVEN IF ADVISED OF THE POSSIBILITY OF SUCH DAMAGE.



**20600 Nordhoff St., Chatsworth CA 91311**  
**1-800-545-6900 818-772-9100 fax: 818-772-9120**  
**www.gefenpro.com support@gefenpro.com**



This product uses UL or CE listed power supplies.