

# Gefen

## 4x4 DVI KVM Matrix USER MANUAL

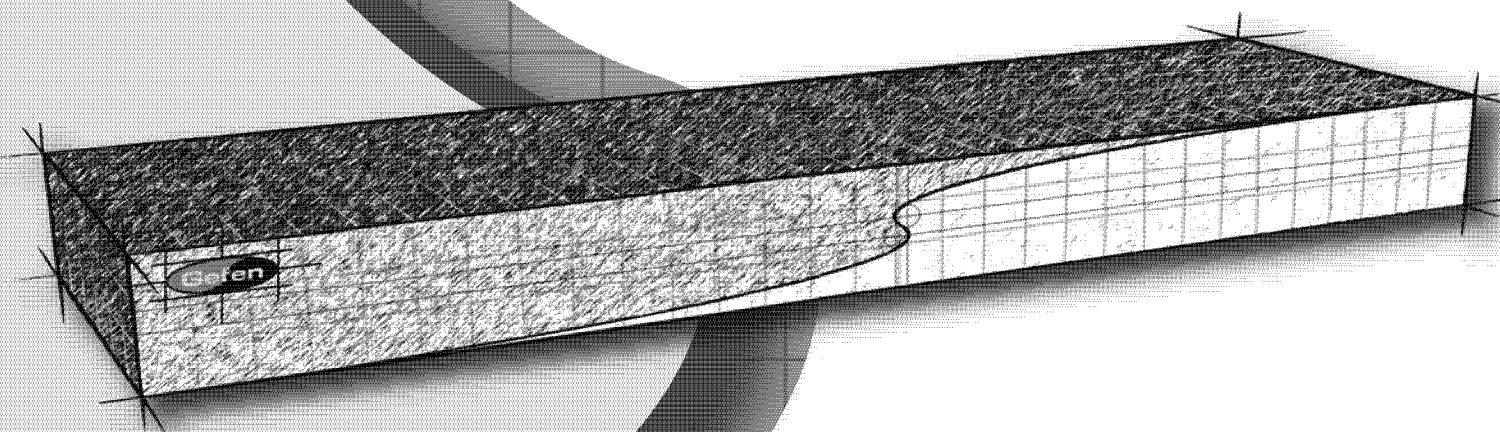

[www.gefen.com](http://www.gefen.com)

## ASKING FOR ASSISTANCE

---

### Technical Support:

Telephone (818) 772-9100  
(800) 545-6900

Fax (818) 772-9120

### Technical Support Hours:

8:00 AM to 5:00 PM Monday through Friday.

### Write To:

Gefen Inc.  
c/o Customer Service  
20600 Nordhoff Street  
Chatsworth, CA 91311

[www.gefen.com](http://www.gefen.com)  
[gsinfo@gefen.com](mailto:gsinfo@gefen.com)

### Notice

Gefen Inc. reserves the right to make changes in the hardware, packaging and any accompanying documentation without prior written notice.

**The 4x4 DVI KVM Matrix** is a trademark of Gefen Inc.

# TABLE OF CONTENTS

---

- 1** Introduction / Operation Notes
- 2** Features
- 3** Panel Layout
- 4** Using the 4x4 DVI Matrix
- 5** RMT16-IR Installation
- 6** IR Codes
- 7** RMT-MATRIX-444 Installation
- 8** RS-232 Interface
- 9** 4x4 DVI Matrix Rack Mount Diagram
- 10** Specifications
- 11** Terminology
- 12** Troubleshooting
- 13** Troubleshooting Diagram
- 14** Warranty

## INTRODUCTION

---

Thank you for purchasing the 4x4 DVI KVM Matrix.

Now you can easily switch four cross-platform computers to four digital displays. Our 4x4 DVI KVM Matrix provides a simple, reliable and highly effective method of creating multiple computer workstations, with each workstation capable of accessing any one of the computers or sources at any time by remote control.

The 4x4 DVI KVM Matrix has four DVI inputs and four DVI outputs. You simply connect your four computers's DVI ports to the Switcher's inputs, then connect your four DVI displays to the Switcher's outputs. USB keyboard and mouse signals and analog audio, once connected, follow the DVI switched input for each computer. .

Note: The switching is done by using either the RMT-16IR remote control, the RS232 port, or the optional CAT5 Remote (EXT-RMT-MATRIX-444). The 4x4 DVI KVM Matrix is rack mountable.

## OPERATION NOTES

---

### READ THESE NOTES BEFORE INSTALLING OR OPERATING THE 4X4 DVI KVM MATRIX

- The 4x4 DVI KVM Matrix is housed in a metal box for better RF shielding.
- The 4x4 DVI KVM Matrix works with all DVI and HDMI displays.
- The 4x4 DVI KVM Matrix is not HDCP compliant.

# FEATURES

---

## Features

- Increases your productivity by providing you with access to four computers from four workstations
- Maintains highest resolution digital video with no loss of quality
- Supports either PC or Mac USB keyboards/mice
- USB 1.1 Matrix Switching capabilities
- Supports analog audio matrixing
- Discrete IR remote (included)
- Supports resolutions up to 1080p, 2K, and 1920 x 1200
- Supports DDWG standards for DVI monitors
- Includes rack ears

## Includes:

- (1) 4x4 DVI KVM Matrix
- (1) RMT-16IR
- (1) 5V Power Supply
- (4) 6ft DVI cables
- (4) 6ft USB cables
- (4) 6ft Audio cables
- (1) Set of Rack Ears

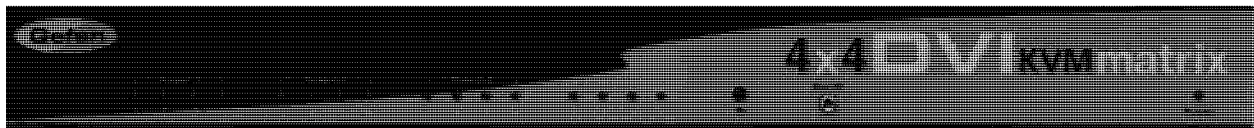

*Front Panel*

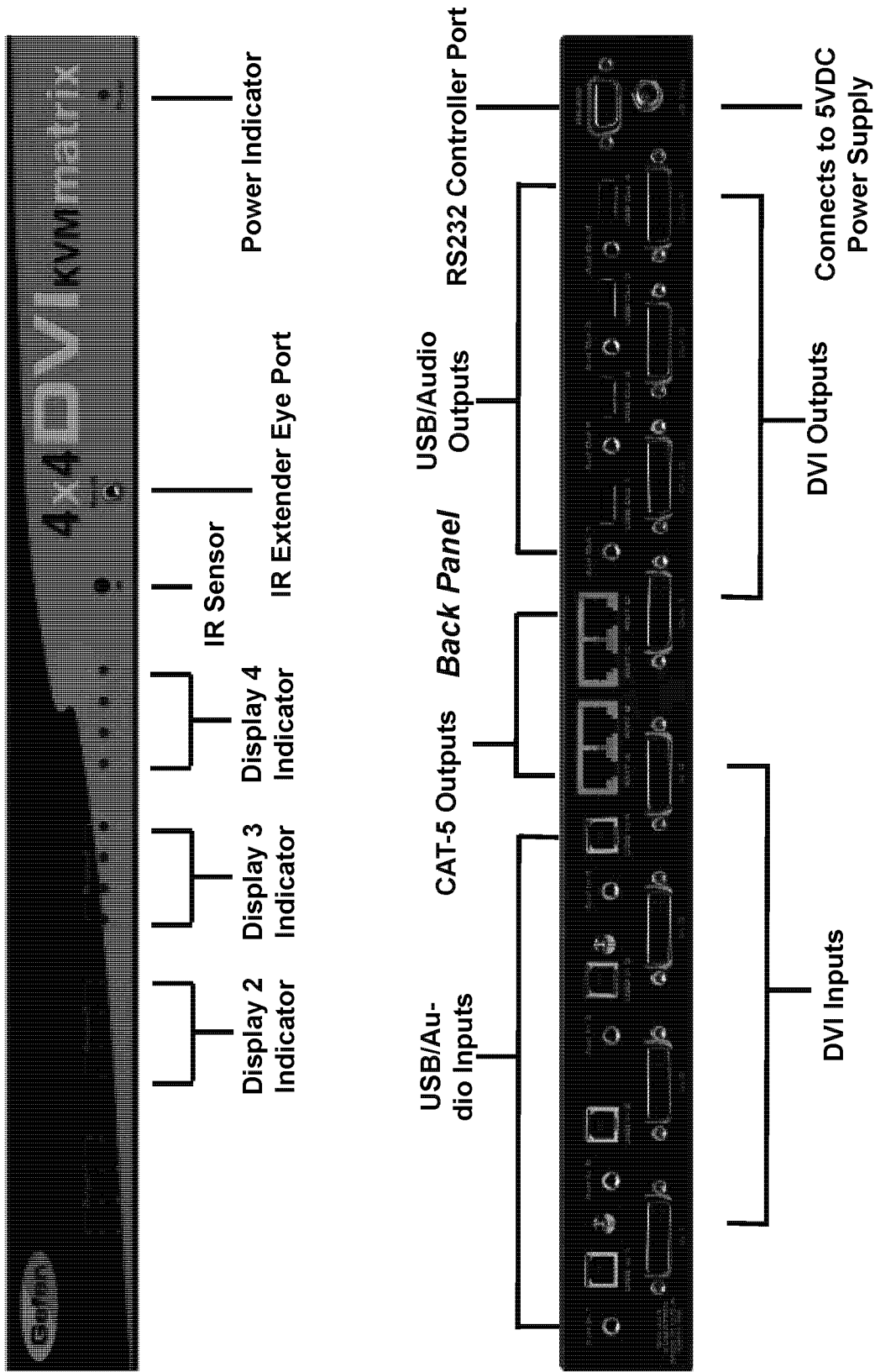

## USING THE 4X4 DVIKVM MATRIX

---

- 1 Connect all the sources to the DVI inputs on the 4x4 DVIKVM Matrix, using the supplied cables.
- 2 Connect the HDMI/DVI display and USB and audio to the outputs on the 4x4 DVIKVM Matrix.
- 3 Connect the 5VDC power supply to the 4x4 DVIKVM Matrix
- 4 Controlling the 4x4 DVIKVM Matrix using the RMT16-IR:

Pressing Buttons...	Switches...
1-4	Display 1 to view Source 1, 2, 3, or 4
5-8	Display 2 to view Source 1, 2, 3, or 4
9-12	Display 3 to view Source 1, 2, 3, or 4
13-16	Display 4 to view Source 1, 2, 3, or 4

**\*Note for computers connected to the DVIKVM Matrix** - When your computer boots up, it looks for an EDID (extended display identification data) from the display to tell it what monitor is connected and what resolution to output. During boot up of the computer you should have **ONLY** one output selected to one input at a time so that the computer gets the EDID of the display that is selected. If you have multiple outputs selected to one computer, the computer will read the EDID of the last output selected to it. If all your displays are the same, or all displays are capable of running at the same resolution then this step does not matter.

You can also use a DVI Detective to eliminate the need to have that matrix selected to the computer during bootup.

## RMT16-IR INSTALLATION

---

1. Remove battery cover from the back of the RMT16-IR remote.
2. Verify that dip switches 1 & 2 are in the down (OFF) position.
3. Insert the battery, hold the battery so that you can see the positive side facing up. The side that is not marked must be facing down.
4. Test the RMT16-IR remote by pressing **ONLY** one button at a time. The indicator light on the remote will flash once each time you press a button. **WARNING:** Do not press multiple buttons simultaneously and do **NOT** press buttons rapidly. These actions will cause the remote to reset and steps 1-4 will have to be repeated.

**\*Note:** The RMT16-IR ships with two batteries. One battery is required for operation, the second battery is complimentary.





# IR CODES

In the event of IR conflicts, please do the following:

1. Remove the battery cover from the back of the RMT16-IR remote.
2. Locate the Dip Switches above the batteries
3. Switch the Dip Switches on the RMT16-IR to any of the combinations pictured below.
4. Dip Switches 1 and 2 in the RMT16-IR correspond with Dip Switches 1 and 2 (Hidden behind metallic tape) inside the 4x4 DVIKVM Matrix respectively. Switch the switches inside the 4x4 DVIKVM Matrix to match the same Remote Channel as the RMT16-IR

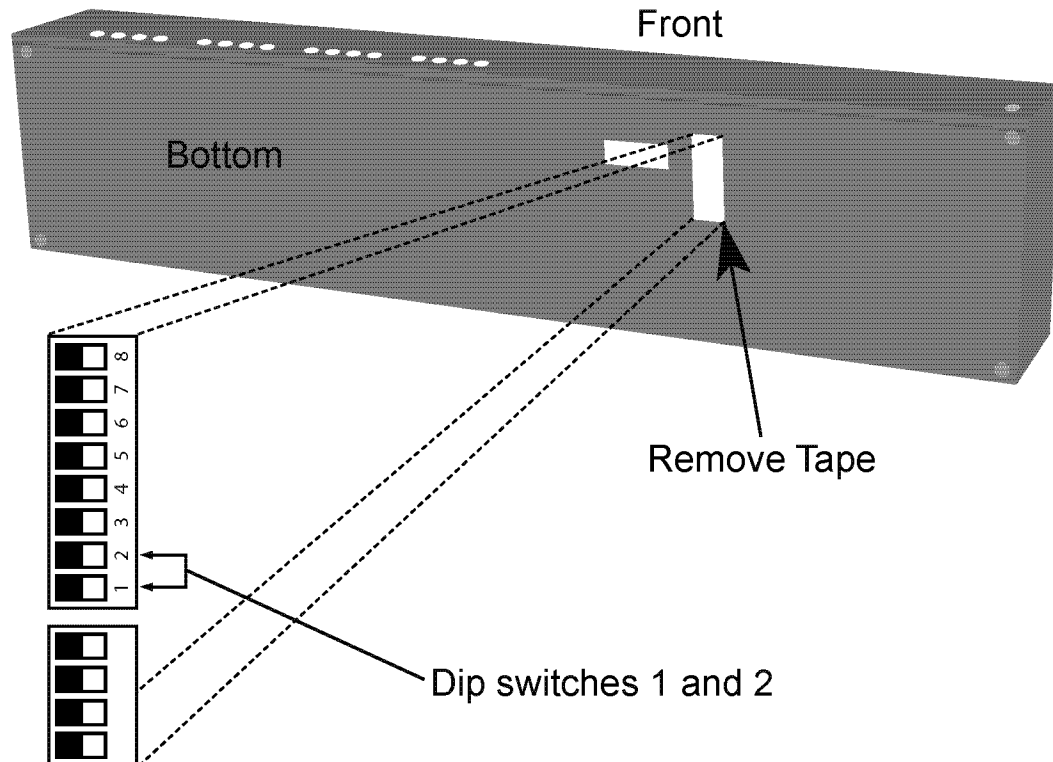
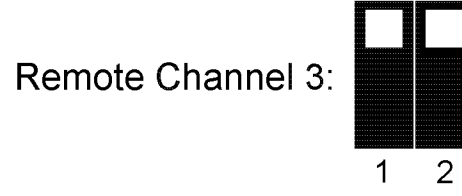
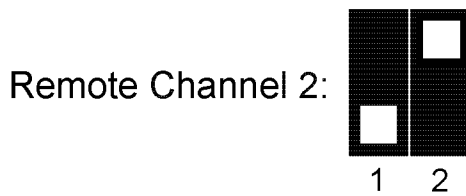
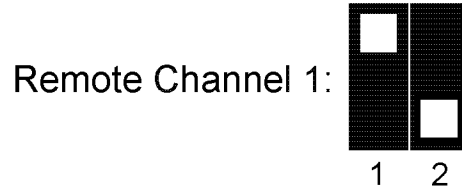
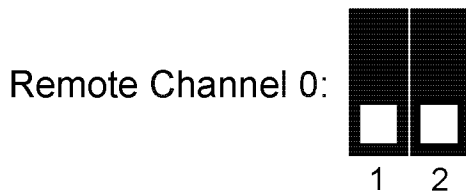

## RMT-MATRIX-444 INSTALLATION (OPTIONAL)

You can use up to 4 RMT-MATRIX-444 units to extend switching functionality to remote locations. Each unit will allow the user to switch their one display between the 4 inputs on the DVIKVM-444N. Follow these steps for each RMT-MATRIX-444 that will be used in your setup.

1. Connect a CAT5/6 cable between the RMT-MATRIX-444 and one of the CAT5 ports on the rear of the DVIKVM-444N. The ports are labeled as RMT A, B, C, and D and correspond with DVI out ports 1, 2, 3, and 4.
2. Use the contact buttons on the RMT-MATRIX-444 to switch between the different inputs connected to the DVIKVM-444N. Optionally, you can use a RMT-4IR (infrared remote) in conjunction with the RMT-MATRIX-444 to switch inputs from a distance.

Input Selection Buttons

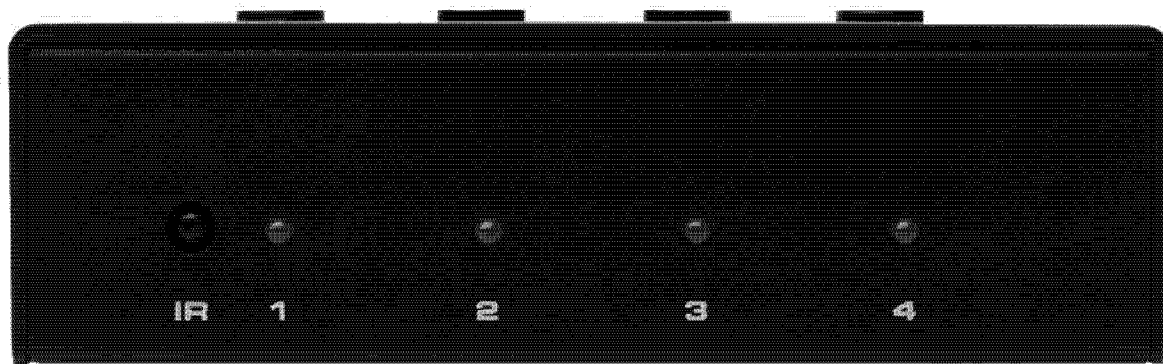

IR Sensor  
(For use with optional IR remote)

Input Selection LED



CAT5/6 Port

IR Sensor Extension Port  
(Extension cable not included)

RS-232 Port

# RS-232 INTERFACE

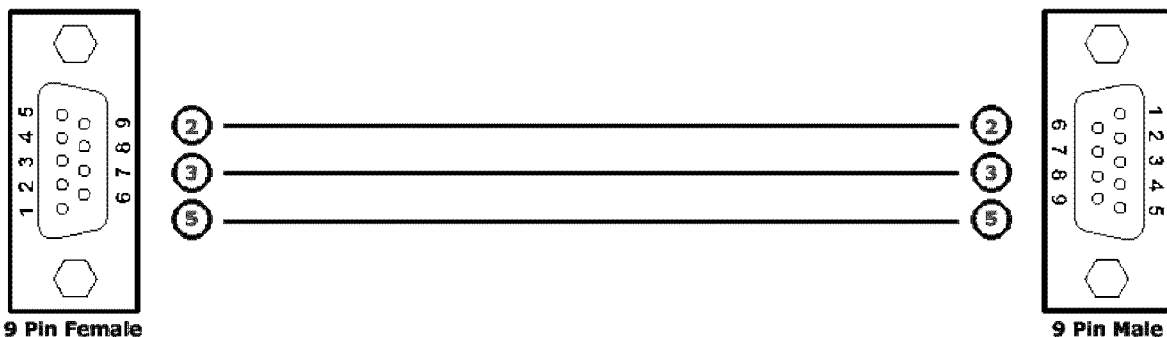

## Binary Table

ASCII	Corresponding RMT16-IR Button	Binary	ASCII	Corresponding RMT16-IR Button	Binary
1	1	0011 0001	9	9	0011 1001
2	2	0011 0010	a	10	0110 0001
3	3	0011 0011	b	11	0110 0010
4	4	0011 0100	c	12	0110 0011
5	5	0011 0101	d	13	0110 0100
6	6	0011 0110	e	14	0110 0101
7	7	0011 0111	f	15	0110 0110
8	8	0011 1000	g	16	0110 0111

## RS232 Settings

Bits per second ..... 19200

Data bits ..... 8

Parity ..... None

Stop bits ..... 1

Flow Control ..... None

# 4x4 HDTV MATRIX RACK MOUNT DIAGRAM

---

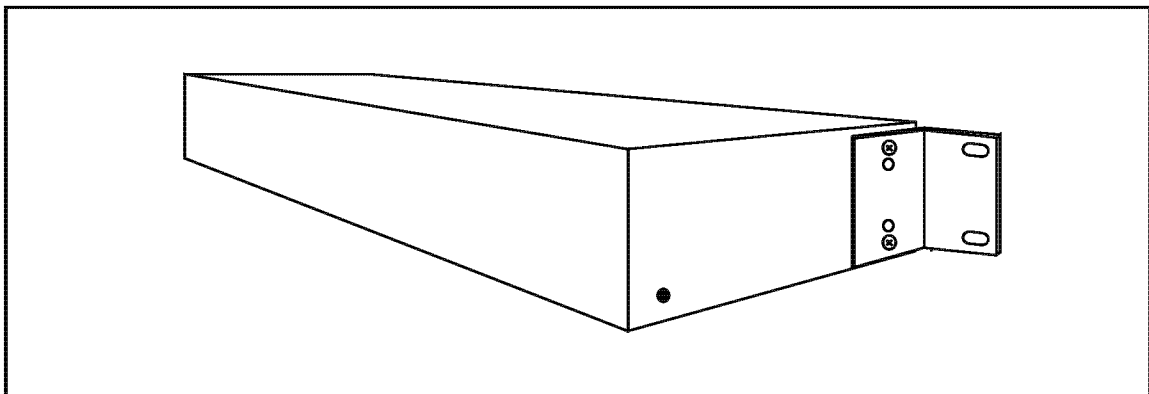
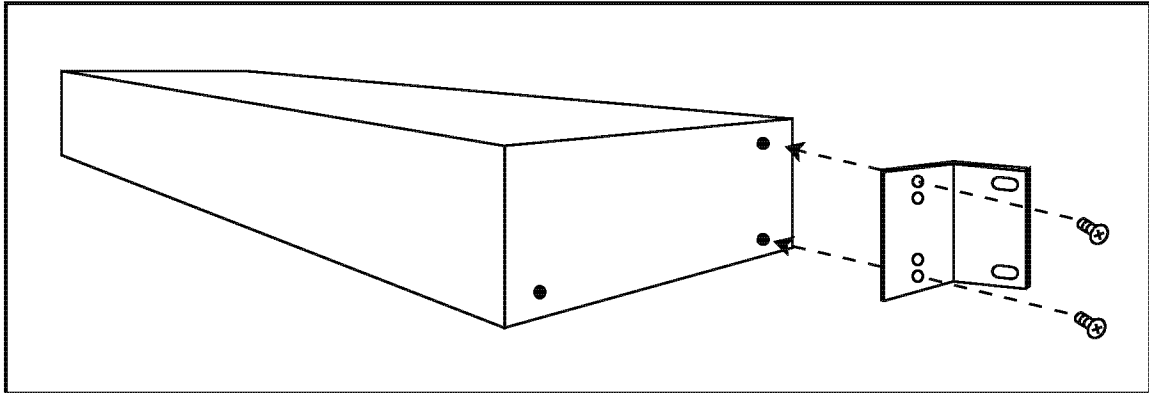
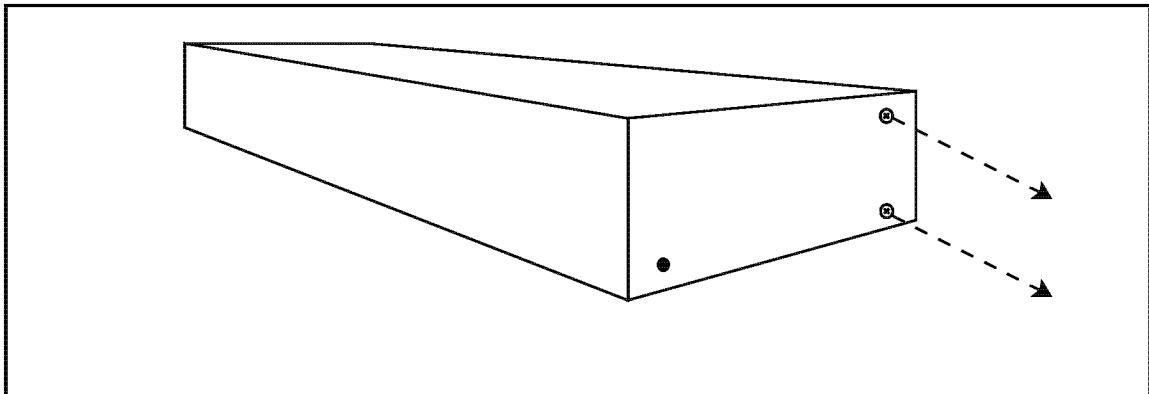
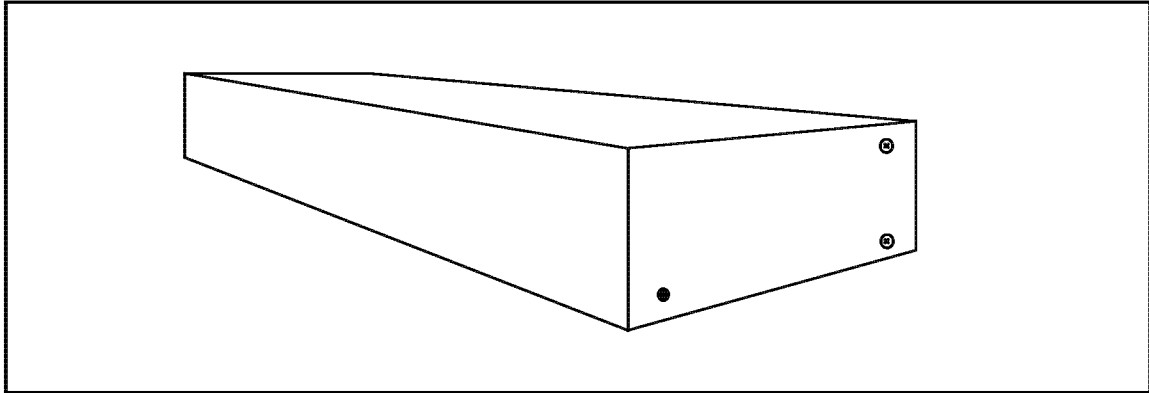

## SPECIFICATIONS

---

Video Amplifier Bandwidth.....	6.6 Gbps
Input Video Signal.....	1.2 volts p-p
Input DDC Signal.....	5 volts p-p (TTL)
Single Link Range.....	1080p/1920 x 1200
DVI Connector.....	DVI-I 29 pin female (digital only)
USB Input Connectors.....	Type "B"
USB Output Connectors.....	Type "A"
Audio Connectors.....	3.5mm mini stereo
Power Supply.....	5V DC
Power Consumption.....	30 watts (max)
Dimensions.....	17"W x 3.25"H x 5.875"D
Rackmountable.....	1U Rack Space
Shipping Weight.....	12 Lbs.

## TERMINOLOGY

---

### ***DDC***

Short form for Display Data Channel. It is a VESA standard for communication between a monitor and a video adapter. Using DDC, a monitor can inform the video card about its properties, such as maximum resolution and color depth. The video card can then use this information to ensure that the user is presented with valid options for configuring the display.

### ***DDWG***

Digital Display Working Group DDWG are the creators of the DVI specification.

### ***DVI***

Digital Visual Interface. Connection standard developed by Intel for connecting computers to digital monitors such as flat panels and DLP projectors. A consumer electronics version, not necessarily compatible with the PC version, is used as a connection standard for HDTV tuners and displays. Transmits an uncompressed digital signal to the display. The latter version uses HDCP copy protection to prevent unauthorized copying.

### ***HDCP***

High-Bandwidth Digital Content Protection. Created by Intel, HDCP is used with HDTV signals over DVI and HDMI connections and on D-Theater D-VHS recordings to prevent unauthorized duplication of copy written material.

### ***HDMI***

The High-Definition Multi-media Interface (HDMI) is an industry-supported, uncompressed, all-digital audio/video interface. HDMI provides an interface between any compatible digital audio/video source, such as a set-top box, DVD player, and AV receiver and a compatible digital audio and/or video monitor, such as a digital television (DTV).

### ***HDTV***

High-Definition Television. The high-resolution subset of our DTV system. The ATSC defines HDTV as a 16:9 image with twice the horizontal and vertical resolution of our existing system, accompanied by 5.1 channels of Dolby Digital audio. The CEA defines HDTV as an image with 720 progressive or 1080 interlaced active (top to bottom) scan lines. 1280:720p and 1920:1080i are typically accepted as high-definition scan rates.

### ***RS-232***

Recommended Standard 232. This is the de facto standard for communication through PC serial ports. It can refer to cables and ports that support the RS232 standard.

### ***VESA***

Video Electronic Standards Association, a consortium of manufacturers formed to establish and maintain industry wide standards for video cards and monitors. VESA was instrumental in the introduction of the Super VGA and Extended VGA video graphics standards with a refresh rate of 70 Hz, minimizing flicker and helping to reduce user eyestrain and fatigue.

# TROUBLESHOOTING

If there is any video noise that appears on your output displays, you can resolve them by using the methods described in this section.

## AUTO EQUALIZATION

Auto equalization is set to ON by default, but in some cases you may have to manually equalize the incoming source signal to eliminate video noise that occurs. Since the equalization is used only on the incoming source signal, manual adjustment of equalization should only be used when the video noise is coming through on a particular incoming source. This is easy to test, as all displays that access this source will exhibit the same type of noise, while other sources will not. Typical video noise can be described as "snow" or brightly colored pixels that are sometimes referred to as "sparkles".

To switch auto equalization off, look on the underside of the 4x4 Matrix and locate the 2 banks of dip switches. They will be covered by some metallic tape that normally conceals their location. There is a bank of 8 dip switches with a bank of 4 dip switches right below it. By default, the bank of 8 dip switches will all be set in the OFF position while the bank of 4 dip switches, which are for auto equalization, will be set to ON. First, determine which display output port is exhibiting the image issue and turn OFF the corresponding auto equalization dip switch using the guide below. Then locate the corresponding equalization trim pot (Located on the diagram on the next page) on the underside of the 4x4 Matrix and turn it in small increments in either a clockwise or counter-clockwise motion until the image clears and no longer exhibits any noise.

## PRE-EMPHASIS

If your input source signals are displaying fine, whether it is using auto or manual equalization, but you're experiencing issues with particular displays, your cable run may be too long and a pre-emphasis can be added to account for the distance that the signal will have to travel. To do this, first determine which display output port is exhibiting this issue, and using the dip switch guideline below, turn on pre-emphasis for that particular port.

Using both of these techniques, individually or in conjunction, will help you tune in your signal to get the best possible image quality out of your Gefen 4x4 DVI KVM Matrix.

### 8 Dip Switch Bank (Pre-emphasis)

Dip Switch #	Name	Description
1	IR Code Dip Switch	Corresponds to Dip Switch 1 on RMT16-IR
2	IR Code Dip Switch	Corresponds to Dip Switch 2 on RMT16-IR
3	Unused	Unused
4	Unused	Unused
5	Output 4 pre-emphasis	Output 4 pre-emphasis
6	Output 3 pre-emphasis	Output 3 pre-emphasis
7	Output 2 pre-emphasis	Output 2 pre-emphasis
8	Output 1 pre-emphasis	Output 1 pre-emphasis

### 4 Dip Switch Bank (Auto-Equalization)

Dip Switch #	Name	Description
1	Auto EQ for Display 1	Auto/Manual Equalization for display 1
2	Auto EQ for Display 2	Auto/Manual Equalization for display 2
3	Auto EQ for Display 3	Auto/Manual Equalization for display 3
4	Auto EQ for Display 4	Auto/Manual Equalization for display 4

# TROUBLESHOOTING - DIAGRAM

