

**Kramer Electronics, Ltd.**



# **USER MANUAL**

**Model:**

**VS-4216**

*16 Port RS-422 Matrix Switcher*

## Contents

<b>1</b>	<b>Introduction</b>	<b>1</b>
<b>2</b>	<b>Getting Started</b>	<b>1</b>
<b>3</b>	<b>Overview</b>	<b>1</b>
3.1	About RS-422	2
3.1.1	Signal Terminology	2
3.1.2	Standards	2
3.1.3	Bi-directional Signals	2
3.1.4	Communication Method via a DB9 Connector	3
3.1.5	Device Definition	3
3.1.6	Automatic Configuration	3
3.1.7	Port Definitions	4
3.1.8	More Than One Slave	4
<b>4</b>	<b>Your Matrix Switcher</b>	<b>4</b>
4.1	Connecting the VS-4216 Matrix Switcher	6
4.1.1	Connecting a PC	6
<b>5</b>	<b>Operating Your Matrix Switcher</b>	<b>7</b>
5.1	Startup Status Display	7
5.2	Bi-directional Connections	7
5.3	MENU Commands Sequence	8
5.3.1	Clearing a Single Slave	8
5.3.2	Clearing a Single Master	9
5.3.3	Clearing All Connections	9
5.3.4	Assigning All to Master	9
5.3.5	Storing and Recalling Setup	9
5.3.6	System Setup Categories	10
<b>6</b>	<b>Technical Specifications</b>	<b>11</b>
<b>7</b>	<b>Communication Protocol</b>	<b>11</b>

## Figures

Figure 1:	Bi-directional Signals I	3
Figure 2:	Bi-directional Signals II	3
Figure 3:	VS-4216 Matrix Switcher	5
Figure 4:	Connecting a PC without using a Null-modem Adapter	7
Figure 5:	Startup Status Display	7
Figure 6:	Sequence of MENU Commands	8

## Tables

Table 1:	Front Panel VS-4216 Matrix Switcher Features	6
Table 2:	Rear Panel VS-4216 Matrix Switcher Features	6
Table 3:	Storing and Recalling Setups	10
Table 4:	System Setup Screen Categories Sequence	11
Table 5:	Technical Specifications of the VS-4216 Matrix Switcher	11
Table 6:	VS-4216 Matrix Switcher Hex Table	12

## 1 Introduction

Dedication by Kramer Electronics since 1981, to the development and manufacture of high quality video/audio equipment, makes the Kramer line an integral part of the finest production and presentation facilities in the world. In recent years, Kramer has redesigned and upgraded most of the line, making the best even better!

The Kramer line of professional video/audio electronics is one of the most versatile and complete available, and is a true leader in terms of quality, workmanship, price/performance ratio and innovation. In addition to our high quality industrial and broadcast switchers and matrix switchers, we also offer excellent amplifiers, remote controllers, processors, interfaces and computer-related products.

Congratulations on purchasing your Kramer **VS-4216 RS-422 Matrix Switcher**. This product is ideal for the following typical applications:

- Remote control of video and audio production studios
- Live broadcast remote control
- CCTV and other remote control applications

The package includes the following items:

- **VS-4216 RS-422 Matrix Switcher**
- Power cord
- Windows 95/98/NT™ Kramer control software
- Null-modem adapter
- This user manual
- Kramer concise product catalog/CD

## 2 Getting Started

We recommend that you:

- Unpack the equipment carefully and save the original box and packaging materials for possible future shipment
- Review the contents of this user manual

## 3 Overview

The **VS-4216** is a 16 port control matrix switcher that:

- Is RS-422 based, as section 3.1 describes
- Offers simple-to-connect automatic master/slave configuration

- Includes a backlit LCD display showing the status of the matrix switcher
- Recalls up to 15 configuration setups via the non-volatile memory
- Is controllable via the front panel buttons, or remotely by RS-485 or RS-232 serial commands transmitted by a touch screen system, PC, or other serial controller

To achieve the best performance:

- Connect only good quality connection cables, thus avoiding interference, deterioration in signal quality due to poor matching, and elevated noise levels (often associated with low quality cables)
- Avoid interference from neighboring electrical appliances that may adversely influence signal quality
- Position your Kramer **VS-4216** in a location free from moisture and away from excessive sunlight and dust

### 3.1 About RS-422

RS-422 control switchers differ substantially from video and audio switchers in both design and in operation, as sections 3.1.1 to 3.1.8 describe.

#### 3.1.1 Signal Terminology

- Connections are between *Master* and *Slave* or *Controller* and *Controlled devices*, rather than the regular *In* and *Out* or *Source* and *Destination* devices. The difference is not merely one of semantics but a vital distinction when trying to understand the concept of RS-422 technology
- With a regular *In* and *Out* switcher, not only does the front panel have separate *In* and *Out* buttons but the rear panel also has separate ports for input and output connectors
- With a *Master* and *Slave* control switcher, the front panel has separate *Master* and *Slave* buttons but the rear panel has shared *Master / Slave* connectors

#### 3.1.2 Standards

RS-422 meets 2 specific standards:

- *TIA/EIA-422-B*, which defines the electrical specifications
- *SMPTE 207M*, which defines the rules of exchanging information for broadcast equipment (the protocol)

#### 3.1.3 Bi-directional Signals

- By using a pair of conductors, each signal travels in both directions via a balanced line between *Master / Slave* devices, as Figure 1 illustrates:

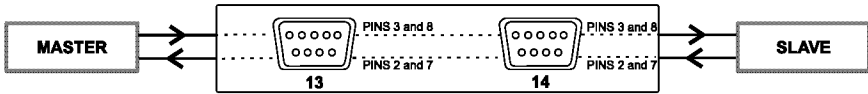

Figure 1: Bi-directional Signals I

- When a Master device changes position with a Slave device, the pins automatically change, as section 3.1.6 describes and as Figure 2 illustrates:

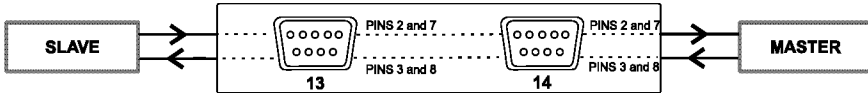

Figure 2: Bi-directional Signals II

### 3.1.4 Communication Method via a DB9 Connector

- The Master unit usually sends a command to the Slave device via pins 3(+) and 8(-) and the Slave device responds to the Master via pins 2(-) and 7(+)
- Keep the communication path clear between the Master and Slave units in both directions, as the Slave device must respond to a command transmitted by the Master
- If the Master receives no response from the Slave, the Master will cancel the communication with the Slave machine and will sometimes flag a message: *no communication*. For example, in video production when a special controller (with play and rewind functionality) is the Master device, each command transmitted to the Slave device must reach that Slave device and that Slave device must respond, otherwise the Master device will disconnect

### 3.1.5 Device Definition

- In many broadcast applications, different machines involved in production can be either Slaves or Masters. Using a device as a Master means that the device *talks* via pins 3 and 8 and *listens* via pins 2 and 7. In another setup, that uses the same device as a Slave, will mean that the device *talks* via pins 2 and 7 and *listens* via pins 3 and 8
- For example, an edit controller always works as a Master. During an editing session, a VTR may be the Slave to the edit controller. However, in a duplication setup, the VTR may become a Master for a second VTR

### 3.1.6 Automatic Configuration

- After connecting the DB9 connectors and cables between the controlled units, the **VS-4216** automatically configures which pins to use in the DB9 connector according to the assignment of each machine

### 3.1.7 Port Definitions

- Modern equipment usually has only one connector, RS-422, which functions as a Master as well as a Slave
- Some older broadcast equipment contains 3 RS-422 connectors; RS-422-In, RS-422-Out and RS-422-In/Out. You can only connect a Master to a RS-422-In port and you can only connect a RS-422-Out port to a Slave. When connecting to a RS-422-In/Out port<sup>1</sup> the unit changes dynamically, automatically reconfiguring the DB9 port pins to be either a Master or a Slave

### 3.1.8 More Than One Slave

- Communication between one Master and one Slave is simple. However, communication between one Master and several Slaves, for example, in duplication applications, is more complicated
- If all the Slaves were to respond simultaneously to a Master command, the system would grind to a halt. To avoid such a situation, a special algorithm in the **VS-4216** dictates that the Master will receive only the response from the highest priority slave<sup>2</sup> with more than one Slave device. For example, in a setup in which port # 7 is the Master, and ports # 5, # 3 and # 6 are Slaves, the **VS-4216** will only transmit to the Master the reply from port # 3 and will discard all the other replies
- Pay special attention: in broadcast applications, the most common reply message from a Slave is the TIMECODE data, therefore, with the above - described algorithm; the response will come from the lowest numbered Slave

## 4 Your Matrix Switcher

Figure 3 illustrates the front and rear panels of the **VS-4216**. Tables 1 and 2 define the front and rear panels of the **VS-4216**, respectively.

---

<sup>1</sup> Item 1 in Table 2

<sup>2</sup> The lowest numbered Slave device

# Your Matrix Switcher

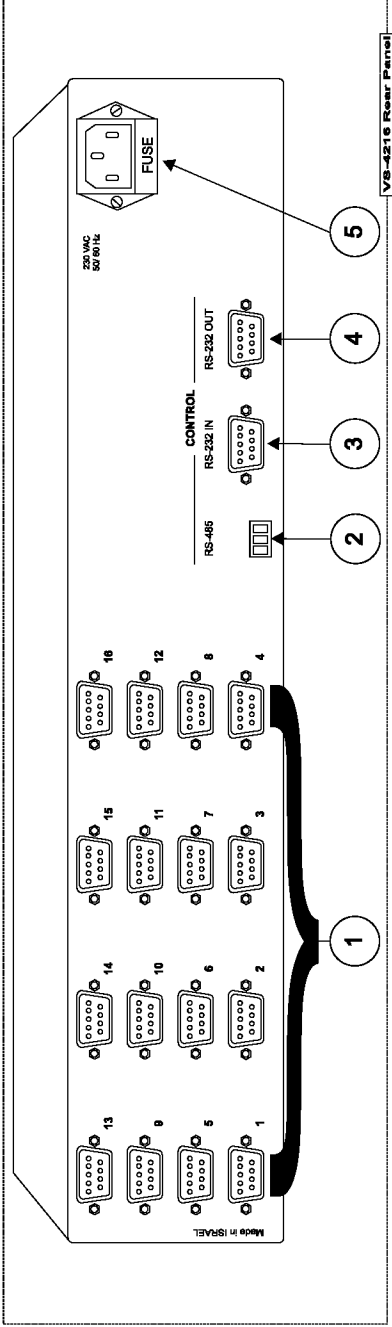
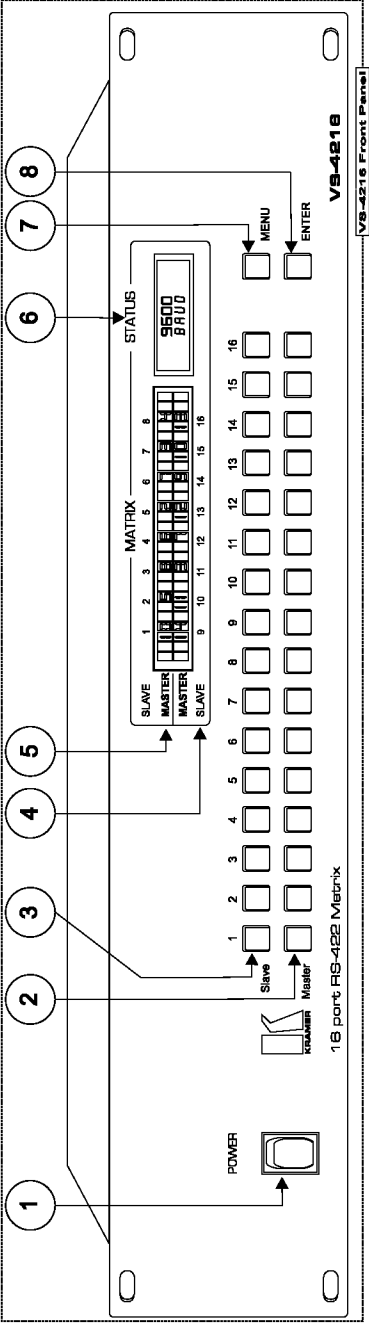

Figure 3: VS-4216 Matrix Switcher

Table 1: Front Panel VS-4216 Matrix Switcher Features

#	Feature	Function
1	Power Switch	Illuminated switch supplying power to the unit
2	Master Buttons	Select 1 - 16 to connect between a Slave device and a Master device
3	Slave Buttons	Select 1 - 16 to connect between a Master device and a Slave device
4	MATRIX SLAVE Labels	Identifies a cross point between each SLAVE to which the MASTER displayed alongside it is connected
5	LCD MATRIX MASTER Display	Displays the selected MASTER switched to the SLAVE (alongside the corresponding SLAVE label) and programming command data
6	LCD STATUS Display	Displays the matrix status
7	MENU Button	For further programming functions
8	ENTER Button	Confirmation button

Table 2: Rear Panel VS-4216 Matrix Switcher Features

#	Feature	Function
1	RS-422 Ports	16 RS-422 bi-directional connectors
2	CONTROL RS-485 Connector	Connector for external RS-485 control
3	CONTROL RS-232 IN Connector	Connect to the PC serial port
4	CONTROL RS-232 OUT Connector	Connect to the RS-232 IN port of the next unit
5	Power Connector with Fuse	AC connector enabling power supply to the unit

## 4.1 Connecting the VS-4216 Matrix Switcher

To connect the VS-4216, connect the following<sup>1</sup> to the rear panel ports:

- Power cord
- DB-9M Connector cables from the Slave and the Master devices
- A PC via the null-modem adapter (when using the Kramer Control software or other controller) if control via RS-232 is required
- RS-485 Phoenix terminal block cable if control via RS-485 is required

### 4.1.1 Connecting a PC

To connect a PC to the VS-4216, using the Null-modem adapter provided with the machine (recommended):

- Connect the RS-232 DB9 rear panel port on the VS-4216 unit to the Null-modem adapter and connect the Null-modem adapter with at least 3 straightforward wires (pins 2, 3 and 5) to the RS-232 DB9 port on your PC

To connect a PC to the VS-4216, without using a Null-modem adapter:

- Connect the RS-232 DB9 port on your PC to the RS-232 DB9 rear panel

<sup>1</sup> Switch OFF the power on each device before connecting it to your VS-4216. After connecting your VS-4216, switch on its power and then switch on the power on each device



port on the **VS-4216** unit, as Figure 4 illustrates (depending on whether the PC has a 9-pin or 25-pin connector)

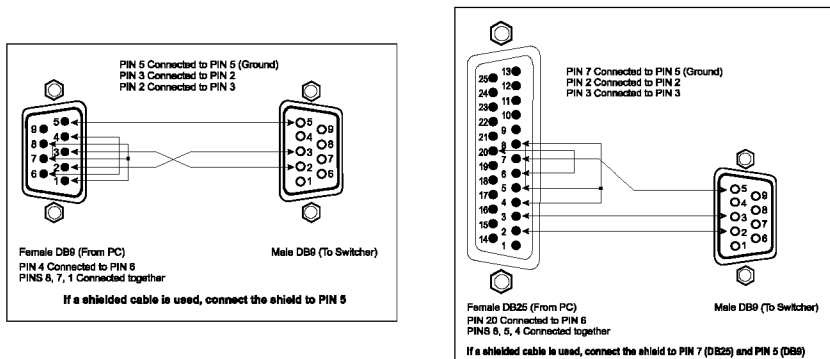

Figure 4: Connecting a PC without using a Null-modem Adapter

## 5 Operating Your Matrix Switcher

Operate your **VS-4216** via:

- The front panel buttons, as this section describes
- RS-232 / RS-485 serial commands transmitted by a touch screen system, PC<sup>1</sup>, or other serial controller

### 5.1 Startup Status Display

After switching on the power, the LCD *MATRIX MASTER* and LCD *STATUS* displays show the following (for software version 1.0):

```

KRAMER ELECTRONICS, Ltd software
16 port RS422 Matrix v. 1.0_
```

Figure 5: Startup Status Display

### 5.2 Bi-directional Connections

To connect a Slave to a Master:

1. Press the appropriate SLAVE button.  
The blinking cursor appears.

<sup>1</sup> For instructions on using the Windows 95/98/NT™ Control Software, refer to the separate user manual (included on the CD-ROM in .pdf format), *Kramer Control Software*

2. Press the appropriate MASTER button.  
The MASTER # appears in the LCD *Matrix Master* display<sup>1</sup> and the SLAVE switches to the MASTER.

Note that:

- Pressing a Slave # button and a Master # button, when the # is the same, displays the message: *Impossible to connect the same MASTER and SLAVE*
- Pressing a Master # button before a Slave # button displays the message: *Assign SLAVE first*

### 5.3 MENU Commands Sequence

Press the MENU button<sup>2</sup> to scan the range of commands, as follows:

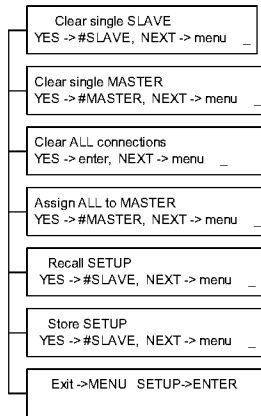

Figure 6: Sequence of MENU Commands

#### 5.3.1 Clearing a Single Slave

Remove a single Slave to Master connection, by:

- Replacing it with a new Slave to Master connection<sup>3</sup>, or
- Deleting it

To delete a single Slave to Master connection, do the following:

1. Press the MENU button once.  
The *Clear single SLAVE* screen appears.

---

1 Item 5 in Figure 3

2 Pressing a button, which is not relevant to the current MENU function, aborts the menu command

3 This automatically clears the previous connection

2. Press the Slave # button that you want to delete.  
The appropriate digits disappear from the LCD *Matrix Master* display, erasing that specific Slave to Master connection.

### 5.3.2 Clearing a Single Master

To delete a single Master to Slave connection, do the following:

1. Press the MENU button twice.  
The *Clear single MASTER* screen appears.
2. Press the Master # button that you want to delete.  
The appropriate digits disappear from the LCD *Matrix Master* display, erasing that specific Master to Slave connection.

Note that:

- Pressing the Master # button when several Slaves are connected to that same Master, erases all the connections to that Master
- Pressing a Master # button that is not connected to any Slave # displays the message: *There are no connections with MASTER # x*

### 5.3.3 Clearing All Connections

To delete all connections, do the following:

1. Press the MENU button 3 times.  
The *Clear All Connections* screen appears.
2. Press the ENTER button.  
All the digits disappear, clearing all Master and Slave connections<sup>1</sup>.

### 5.3.4 Assigning All to Master

To assign all the Slave connections to the Master, do the following:

1. Press the MENU button 4 times.  
The *Assign ALL to MASTER* screen appears.
2. Press the Master # button to which you want to assign all the Slaves.  
This assigns that Master # to all the Slave connections, except the Slave connection with the same number as the Master # button<sup>2</sup>.

### 5.3.5 Storing and Recalling Setup

Store and recall up to 15 settings in memory. For example, using the Slave # buttons 1 to 15 (but not # 16), you can switch Slave # 1 and Slave # 2 to different Masters, and save those settings as different setups:

---

<sup>1</sup> This action resets the VS-4216 to the default stage, with no Slave connected to a Master

<sup>2</sup> This action converts the VS-4216 to a 1x15 Distribution Amplifier for RS-422 signals

Table 3: Storing and Recalling Setups

SLAVE to MASTER connection:	Appears as follows:	Stored as Setup:
Switch SLAVE # 1 to MASTER # 4 Switch SLAVE # 2 to MASTER # 6	04 06	# 1
Switch SLAVE # 1 to MASTER # 9 Switch SLAVE # 2 to MASTER # 3	09 03	# 2
Switch SLAVE # 1 to MASTER # 6 Switch SLAVE # 2 to MASTER # 8	06 08	# 3

### 5.3.5.1 Storing Setup

To store a setup, do the following:

1. Press the MENU button 6 times.  
The *Store SETUP* screen appears.
2. Press the Slave # button, where the Slave # represents the setup number.
3. Press the ENTER button.  
This stores that setup.

### 5.3.5.2 Recalling Setup

To recall a setup, do the following:

1. Press the MENU button 5 times.  
The *Recall SETUP* screen appears.
2. Press the Slave # button, where the Slave # represents the setup number.  
This displays that specific setup<sup>1</sup>.
3. Press the ENTER button.  
This recalls the specific setup.

Note that:

- Saving a setup to an already allocated setup #, replaces that previous setup

### 5.3.6 System Setup Categories

To setup the system:

1. Press the MENU button 7 times.  
The *Exit ->MENU SETUP->ENTER* screen appears.
2. Press the ENTER button.  
The first in the sequence of 4 screens, *Keyboard action*, appears.
3. Continue to press the MENU button, as required, until you access the required system setup category. Follow the instructions in Table 4:

<sup>1</sup> Pressing another Slave # button before pressing ENTER, will display that other setup, allowing you to scan the setups

Table 4: System Setup Screen Categories Sequence

Press MENU to select:	Details of the Command:
<p><b>Keyboard action setting</b></p> <p>Choose the At Once mode, for immediate execution, by pressing Slave #1, or the Confirm mode, when actions require confirmation but are protected against erroneous switching, by pressing Slave #2 and then ENTER</p>	<div style="border: 1px solid black; padding: 5px; margin: 5px;">KEYBOARD action YES -&gt; enter, NEXT -&gt; menu _</div> <div style="border: 1px solid black; padding: 5px; margin: 5px;">slave #1: action AT ONCE    current slave #2: confirm &lt;ENTER&gt;: CONFIRM_</div>
<p><b>AUTO store current SETUP?</b></p> <p>Auto save the current setup, or do not auto save the current setup, by pressing ENTER</p>	<div style="border: 1px solid black; padding: 5px; margin: 5px;">AUTO store current SETUP No-&gt; enter, NEXT -&gt; menu _</div>
<p><b>Identify MACHINE</b></p> <p>Display essential information (product name and version number) for technical support purposes. After a few seconds, the <i>Change MACHINE NUMBER</i> command appears. Press ENTER and change via the Slave # buttons</p>	<div style="border: 1px solid black; padding: 5px; margin: 5px;">KRAMER ELECTRONICS, Ltd software 16 port RS422 Matrix v. 1.0_</div> <div style="border: 1px solid black; padding: 5px; margin: 5px;">Change MACHINE NUMBER?    Current YES -&gt; ENTER                    MACH.#01_</div> <div style="border: 1px solid black; padding: 5px; margin: 5px;">Enter new MACHINE NUMBER    Curr. #01 use SLAVEkey 1-15              New #_</div>
<p><b>Initial RESET</b></p> <p>Reset the unit without having to switch the power on and off (preventing overloading)</p>	<div style="border: 1px solid black; padding: 5px; margin: 5px;">Initial RESET YES -&gt; enter, NEXT -&gt; menu _</div> <div style="border: 1px solid black; padding: 5px; margin: 5px;">WARNING !!!    confirm RESET all settings? &lt;ENTER&gt; _</div>

## 6 Technical Specifications

Table 5 includes the technical specifications:

Table 5: Technical Specifications of the VS-4216 Matrix Switcher

Connectors:	16 in/out RS-422 ports on DB-9 female connectors, fully compliant to the TIA/EIA-422-B standard RS-232 control via DB-9F connector (RS-232 out on DB-9M connector), RS-485 on terminal block assembly
Control:	Manual with pushbuttons on front panel, RS-485 and RS-232 PC interface
Dimensions:	19-inch (W), 7-inch (D) 2U (H) rack-mountable
Power Source:	230 VAC, 50/60 Hz, (115VAC, U.S.A.) 15VA
Weight:	3.5 kg. (7.8 lbs.) approx
Accessories:	Power cord, Windows™ 95/98 control software, null modem adapter

## 7 Communication Protocol

Table 6 includes the Protocol 2000 hexadecimal codes (the protocol uses 4 bytes of information, data is at 9600 baud, no parity, 8 data bits and one stop bit). Full details are available at our web site: [www.kramerelectronics.com](http://www.kramerelectronics.com).



---

## LIMITED WARRANTY

Kramer Electronics (hereafter *Kramer*) warrants this product free from defects in material and workmanship under the following terms.

### HOW LONG IS THE WARRANTY

Labor and parts are warranted for three years from the date of the first customer purchase.

### WHO IS PROTECTED?

Only the first purchase customer may enforce this warranty.

### WHAT IS COVERED AND WHAT IS NOT COVERED

Except as below, this warranty covers all defects in material or workmanship in this product. The following are not covered by the warranty:

1. Any product which is not distributed by Kramer, or which is not purchased from an authorized Kramer dealer. If you are uncertain as to whether a dealer is authorized, please contact Kramer at one of the agents listed in the web site [www.kramerelectronics.com](http://www.kramerelectronics.com).
2. Any product, on which the serial number has been defaced, modified or removed.
3. Damage, deterioration or malfunction resulting from:
  - i) Accident, misuse, abuse, neglect, fire, water, lightning or other acts of nature
  - ii) Product modification, or failure to follow instructions supplied with the product
  - iii) Repair or attempted repair by anyone not authorized by Kramer
  - iv) Any shipment of the product (claims must be presented to the carrier)
  - v) Removal or installation of the product
  - vi) Any other cause, which does not relate to a product defect
  - vii) Cartons, equipment enclosures, cables or accessories used in conjunction with the product

### WHAT WE WILL PAY FOR AND WHAT WE WILL NOT PAY FOR

We will pay labor and material expenses for covered items. We will not pay for the following:

1. Removal or installations charges.
2. Costs of initial technical adjustments (set-up), including adjustment of user controls or programming. These costs are the responsibility of the Kramer dealer from whom the product was purchased.
3. Shipping charges.

### HOW YOU CAN GET WARRANTY SERVICE

1. To obtain service on you product, you must take or ship it prepaid to any authorized Kramer service center.
2. Whenever warranty service is required, the original dated invoice (or a copy) must be presented as proof of warranty coverage, and should be included in any shipment of the product. Please also include in any mailing a contact name, company, address, and a description of the problem(s).
3. For the name of the nearest Kramer authorized service center, consult your authorized dealer.

### LIMITATION OF IMPLIED WARRANTIES

All implied warranties, including warranties of merchantability and fitness for a particular purpose, are limited in duration to the length of this warranty.

### EXCLUSION OF DAMAGES

The liability of Kramer for any effective products is limited to the repair or replacement of the product at our option. Kramer shall not be liable for:

1. Damage to other property caused by defects in this product, damages based upon inconvenience, loss of use of the product, loss of time, commercial loss; or:
2. Any other damages, whether incidental, consequential or otherwise. Some countries may not allow limitations on how long an implied warranty lasts and/or do not allow the exclusion or limitation of incidental or consequential damages, so the above limitations and exclusions may not apply to you.

This warranty gives you specific legal rights, and you may also have other rights, which vary from place to place.

**NOTE:** All products returned to Kramer for service must have prior approval. This may be obtained from your dealer.

This equipment has been tested to determine compliance with the requirements of:

- EN-50081: "Electromagnetic compatibility (EMC);  
generic emission standard.  
Part 1: Residential, commercial and light industry"
- EN-50082: "Electromagnetic compatibility (EMC) generic immunity standard.  
Part 1: Residential, commercial and light industry environment".
- CFR-47: FCC Rules and Regulations:  
Part 15: "Radio frequency devices  
Subpart B – Unintentional radiators"

### CAUTION!

- Servicing the machines can only be done by an authorized Kramer technician. Any user who makes changes or modifications to the unit without the expressed approval of the manufacturer will void user authority to operate the equipment.
- Use the supplied DC power supply to feed power to the machine.
- Please use recommended interconnection cables to connect the machine to other components.



**The list of Kramer distributors appears on our web site:  
[www.kramerelectronics.com](http://www.kramerelectronics.com)**

**We welcome your questions, comments and feedback.**

---

**Kramer Electronics, Ltd.**

3 Am VeOlamo Street, Jerusalem 95463, Israel Tel: (+972-2)-654-4000

Fax: (+972-2)-653-5369, E-mail: [kramere1@netvision.net.il](mailto:kramere1@netvision.net.il)