

**Kramer Electronics, Ltd.**

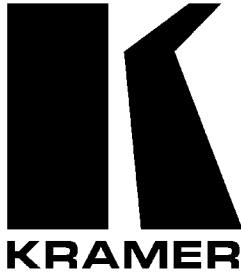

# **USER MANUAL**

## **Models:**

*VS-402xl, 4x2 Vertical Interval Video-Audio Matrix Switcher*

*VS-602xl, 6x2 Vertical Interval Video-Audio Matrix Switcher*

## Contents

<b>1</b>	<b>Introduction</b>	<b>1</b>
<b>2</b>	<b>Getting Started</b>	<b>1</b>
<b>3</b>	<b>Overview</b>	<b>2</b>
<b>4</b>	<b>Your Vertical Interval Video-Audio Matrix Switcher</b>	<b>2</b>
<b>5</b>	<b>Connecting a Vertical Interval Video-Audio Matrix Switcher</b>	<b>5</b>
5.1	Controlling via RS-232 (for example, using a PC)	6
5.2	Controlling via RS-485	6
5.3	Setting the Dipswitches	7
5.3.1	Setting the MACHINE #	8
5.4	Connecting the REMOTE Connector	9
<b>6</b>	<b>Cascading Vertical Interval Video-Audio Matrix Switchers</b>	<b>10</b>
6.1	Cascading Units in an Input Expansion Configuration	10
6.2	Cascading a set of Units in a (RGB) Parallel Configuration	12
6.3	Cascading Individual Units in a Control Configuration	14
6.3.1	Control Configuration via RS-232 and RS-485	14
6.3.2	Control Configuration via RS-485	15
6.4	Looping Units in an Increased Output Configuration	16
<b>7</b>	<b>Operating the Vertical Interval Video-Audio Matrix Switcher</b>	<b>17</b>
7.1	Choosing the Audio-Follow-Video or Breakaway Option	18
7.1.1	Setting the Audio-Follow-Video Option	18
7.1.2	Setting the Breakaway Option	18
<b>8</b>	<b>Technical Specifications</b>	<b>18</b>
<b>9</b>	<b>Table of Hex Codes for Serial Communication</b>	<b>19</b>
<b>10</b>	<b>Communication Protocol</b>	<b>20</b>

## Figures

Figure 1:	Vertical Interval Video-Audio Matrix Switchers	3
Figure 2:	VS-602x1 Underside	5
Figure 3:	Connecting a PC without using a Null-modem Adapter	6
Figure 4:	Controlling via RS-485 (for example, using a VS-3000)	7
Figure 5:	SETUP Set of 8 Dipswitches	8
Figure 6:	Remote Connector PIN # Settings	9
Figure 7:	Cascading Units in an Input Expansion Configuration	12
Figure 8:	Cascading a set of 3 Units in a (RGB) Parallel Configuration	13
Figure 9:	Cascading Individual Units in a Control Configuration via RS-232 and RS-485	15
Figure 10:	Cascading Individual Units in a Control Configuration via RS-485	16
Figure 11:	Adding Outputs by Looping Units	17

**Tables**

Table 1: Front Panel Vertical Interval Video-Audio Matrix Switcher Features	4
Table 2: Rear Panel Vertical Interval Video-Audio Matrix Switcher Features	4
Table 3: VS-602xl Underside Features	5
Table 4: Dipswitch Settings	8
Table 5: Machine # Dipswitch Settings	9
Table 6: Technical Specifications of the Vertical Interval Video-Audio Matrix Switcher	19
Table 7: VS-402xl/VS-602xl Hex Codes for Switching via RS-232/RS-485	19
Table 8: Protocol Definitions	20
Table 9: Instruction Codes	21

## 1 Introduction

Dedication by Kramer Electronics since 1981, to the development and manufacture of high quality video/audio equipment, makes the Kramer line an integral part of the finest production and presentation facilities in the world. In recent years, Kramer has redesigned and upgraded most of the line, making the best even better! The Kramer line of professional video/audio electronics is one of the most versatile and complete available, and is a true leader in terms of quality, workmanship, price/performance ratio and innovation. In addition to our high quality Kramer switchers and matrices, we also offer excellent distribution amplifiers, remote controllers, processors, interfaces, scalars and computer-related products.

Congratulations on purchasing your Kramer **VS-402x1** 4x2 *Vertical Interval Video-Audio Matrix Switcher* and/or **VS-602x1** 6x2 *Vertical Interval Video-Audio Matrix Switcher*.

Your Kramer **VS-402x1/VS-602x1** is ideal for the following typical applications:

- Live broadcast or presentation applications such as switching between cameras in real-time
- CCTV, home theater
- Rental and staging applications
- Video production studios

The **VS-402x1** and/or the **VS-602x1** package includes the following items:

- Vertical Interval Video-Audio Matrix Switcher
- Power cord
- Windows 95/98/NT™ Kramer control software
- Null-modem adapter
- This user manual
- Kramer concise product catalog/CD

## 2 Getting Started

We recommend that you:

- Unpack the equipment carefully and save the original box and packaging materials for possible future shipment
- Review the contents of this user manual

### 3 Overview

The Kramer **VS-602xl** (a 6x2 switcher) and **VS-402xl** (a 4x2 switcher) are high performance vertical interval matrix switchers for composite video and stereo balanced audio signals. Both are true matrix switchers - enabling the user to route any input to any or all outputs simultaneously.

In addition, both the **VS-602xl** and the **VS-402xl**:

- Have video bandwidth that exceeds 300 MHz, ensuring that they remain transparent even in the most critical applications
- Include audio-follow-video or audio breakaway option
- Produce glitch-free transitions, when sources share a common reference sync<sup>1</sup>
- Include 2 sets of INPUT SELECTOR buttons (one set for each output) and 5 front panel control buttons
- Include 2 duplicate outputs per set of INPUT SELECTOR buttons (4 outputs in total)
- Include a “Take” button<sup>2</sup> for precise switch control and a “Lock” button to prevent tampering with the front panel
- Are controllable via the front panel buttons, or remotely by RS -485 or RS-232 serial commands transmitted by a touch screen system, PC, or other serial controller

Achieving the best performance means:

- Connecting only good quality connection cables, thus avoiding interference, deterioration in signal quality due to poor matching, and elevated noise levels (often associated with low quality cables)
- Avoiding interference from neighboring electrical appliances that may adversely influence signal quality
- Positioning your Kramer **VS-402xl** or **VS-602xl** in a location free from moisture and away from excessive sunlight and dust

### 4 Your Vertical Interval Video-Audio Matrix Switcher

Figure 1 illustrates the front and rear panels of both the **VS-402xl** and the **VS-602xl**. Tables 1 and 2 define their front and rear panels.

---

<sup>1</sup> As it switches during the vertical interval

<sup>2</sup> Also enables the user to place multiple switches in a queue and then activate them with one touch of this button, or via a single serial command

## Your Vertical Interval Video-Audio Matrix Switcher

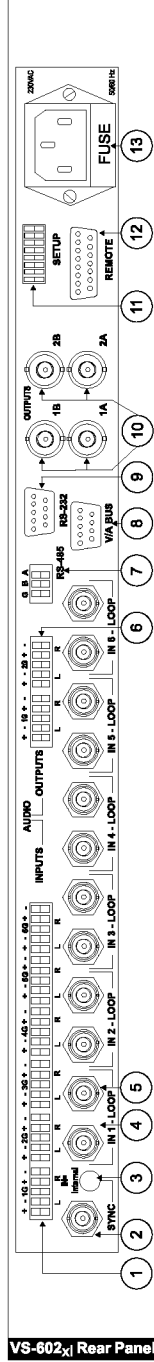
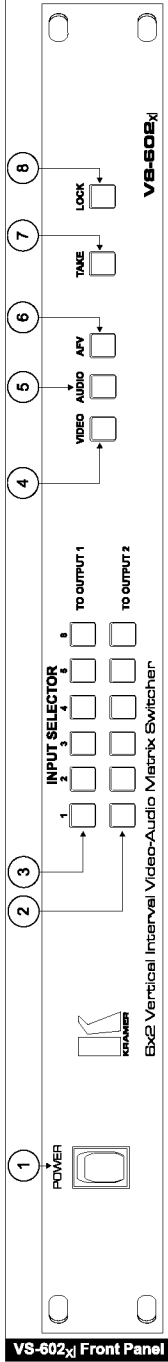
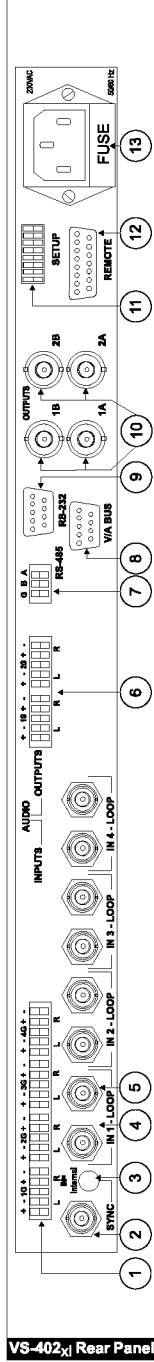
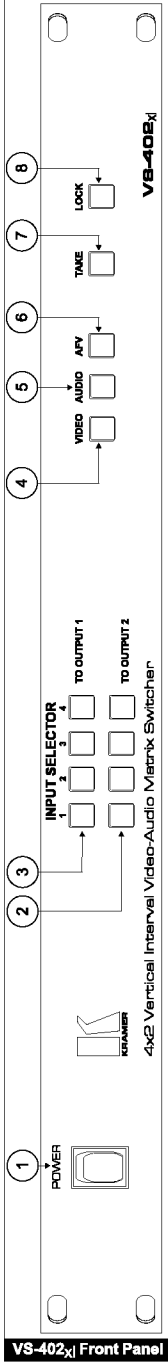

Figure 1: Vertical Interval Video-Audio Matrix Switchers

*Table 1: Front Panel Vertical Interval Video Audio Matrix Switcher Features*

#	Feature	Function
1	Power Switch	Illuminated switch supplying power to the unit
2	INPUT SELECTOR TO OUTPUT 1 Buttons <sup>1</sup>	Select the input to switch to OUTPUTS 1A and 1B
3	INPUT SELECTOR TO OUTPUT 2 Buttons <sup>1</sup>	Select the input to switch to OUTPUTS 2A and 2B
4	VIDEO Button <sup>2</sup>	When pressed actions relate to video
5	AUDIO Button <sup>2</sup>	When pressed actions relate to audio
6	AFV Button <sup>3</sup>	When pressed audio channels follow the video channels
7	TAKE Button	Pressing TAKE toggles the mode between the CONFIRM mode <sup>4</sup> and the AT ONCE mode (user confirmation per action is unnecessary)
8	LOCK Button	Disengages the front panel switches

*Table 2: Rear Panel Vertical Interval Video Audio Matrix Switcher Features*

#	Feature	Function
1	AUDIO INPUTS Terminal Block Connectors <sup>1</sup>	Connects the audio sources
2	SYNC BNC Connector	Connects to the external SYNC source
3	Sync Source Selector (IN=Internal) Button	Pushing in selects internal sync <sup>5</sup> , releasing selects the external sync <sup>6</sup> source
4	IN BNC Connectors <sup>1</sup>	Connects the composite video sources
5	LOOP BNC Connectors <sup>1</sup>	For looping to increase output availability
6	AUDIO OUTPUTS Terminal Block Connectors	Connects the 2 audio acceptors
7	RS-485 Connector	RS-485 detachable terminal block port
8	V/A BUS Connector	DB9F connector connects to the V/A BUS Connector on the next unit(s) via a short DB9M flat cable when cascading in an input expansion configuration
9	RS-232 Connector	DB 9F connector connects to PC or other Serial Controller
10	OUTPUTS 1A; 1B; 2A; 2B BNC Connectors	Connects to the output acceptors
11	SETUP	Dipswitches for setup
12	REMOTE Connector	Attach a specific PIN to PIN 9 or PIN 10 to switch an input via a remote dry contact switch <sup>7</sup> (refer to section 5.4)
13	Power Connector with Fuse	AC connector enabling power supply to the unit

---

1 Four on the VS-402xl; six on the VS-602xl

2 Refer to section 7.1.2

3 Refer to section 7.1.1

4 When in Confirm mode, the TAKE button illuminates

5 On the IN 1 connector

6 On the SYNC connector

7 The appropriate front panel INPUT SELECTOR button illuminates

Figure 2 and Table 3 define the 6 TERM switches and the 4 trimmers on the underside of the VS-602xl unit<sup>1</sup>. Figure 2 shows to which LOOP connector each TERM switch relates and the location of the Trimmers for adjusting OUTPUTS 1 and 2 and for adjusting EQ. 1 and EQ. 2.

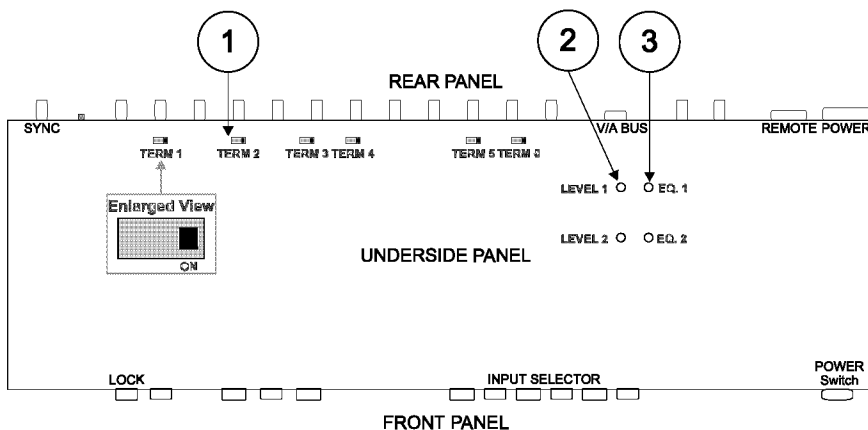

Figure 2: VS 602xl Underside

Table 3: VS 602xl Underside Features

#	Feature	Function
1	TERM Switch	Move to the right (ON position) to terminate with 75 Ω, or move to the left for looping <sup>2</sup>
2	LEVEL Trimmers	Adjusts <sup>3</sup> the output signal level for OUTPUTS 1 and 2
3	EQ. Trimmers	Adjusts <sup>3</sup> the equalization level (EQ.) for OUTPUTS 1 and 2

## 5 Connecting a Vertical Interval Video-Audio Matrix Switcher

To connect the VS-402xl/VS-602xl, connect the following<sup>4</sup> to the rear panel:

1. The composite video sources and acceptors, as well as the appropriate audio sources and acceptors.
2. The power cord.

1 The underside of the VS-402xl unit contains only 4 TERM switches

2 The factory default

3 Insert a screwdriver into the small hole and carefully rotate it, trimming the OUTPUT level or EQ level

4 Switch OFF the power on each device before connecting it to your VS-402xl/VS-602xl Switcher. After connecting your VS-402xl/VS-602xl Switcher, switch on its power and then switch on the power on each device. Switching on the VS-402xl/VS-602xl Switcher, recalls the last status prior to powering down



In addition, you can choose to connect the following options:

- A PC (when using the *Kramer Control software*, for example) or other RS-232 (refer to section 5.1) or RS-485 controller (refer to section 5.2).
- A remote dry contact switch (refer to section 5.4)

## 5.1 Controlling via RS-232 (for example, using a PC)

To connect a PC to the **VS-402xl/VS-602xl** unit, using the Null-modem adapter provided with the machine (recommended):

- Connect the RS-232 DB9 rear panel port on the **VS-402xl/VS-602xl** unit to the Null-modem adapter and connect the Null-modem adapter with a 9 wire flat cable to the RS-232 DB9 port on your PC

To connect a PC to the **VS-402xl/VS-602xl** unit, without using a Null-modem adapter:

- Connect the RS-232 DB9 port on your PC to the RS-232 DB9 rear panel port on the **VS-402xl/VS-602xl** unit, as Figure 3 illustrates (depending on whether the PC has a 9-pin or 25-pin connector)

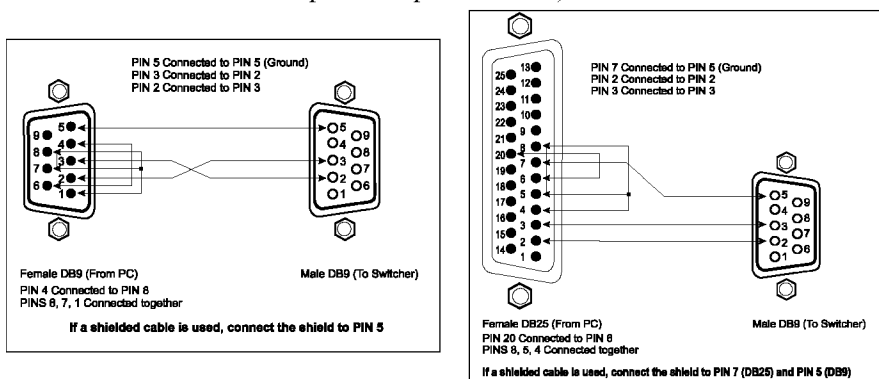

Figure 3: Connecting a PC without using a Null modem Adapter

You can connect up to 8 **VS-402xl/VS-602xl** units to the PC via the Null-modem adapter and the RS-232 port, and the RS-485 ports, as Figure 9 illustrates.

## 5.2 Controlling via RS-485

You can control a **VS-402xl/VS-602xl** unit via an RS-485 controller, for example, a PC (equipped with an RS-485 interface) or a Master Programmable Remote Control system such as the Kramer **VS-3000**.

To connect a **VS-3000** to a **VS-402xl/VS-602xl** unit<sup>1</sup> (see Figure 4):

1. Connect the RS-485 terminal block port on the **VS-3000** to the RS-485 port on the **VS-402xl/VS-602xl** unit, as follows:
  - Connect the “A” (+) PIN on the RS-485 rear panel port of the **VS-3000** to the “A” (+) PIN on the RS-485 rear panel port of the **VS-402xl/VS-602xl** unit
  - Connect the “B” (-) PIN on the RS-485 rear panel port of the **VS-3000** to the “B” (-) PIN on the RS-485 rear panel port of the **VS-402xl/VS-602xl** unit
  - If shielded twisted pair cable is used, the shield may be connected to the “G” (Ground) PIN on one of the units (for example, on the **VS-3000**)
2. Set the **VS-402xl/VS-602xl** unit as MACHINE # 1, according to Table 5
3. Set the SETUP dipswitches on the **VS-402xl/VS-602xl** unit, as follows:
  - Set Dip 4 ON, Dip 6 ON and Dip 7 ON
  - Set Dip 5, and Dip 8 OFF

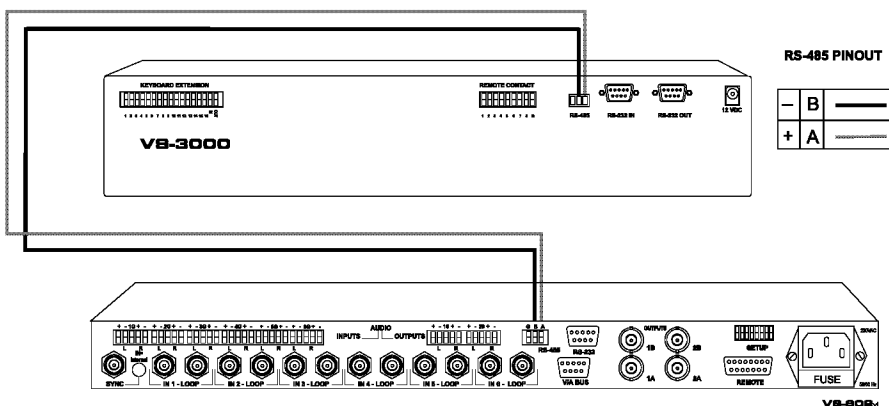

Figure 4: Controlling via RS 485 (for example, using a VS 3000)

### 5.3 Setting the Dipswitches

Figure 5 illustrates the factory default *SETUP* dipswitches:

<sup>1</sup> You can control up to 8 VS-402xl/VS-602xl units, as section 6.3.2 describes

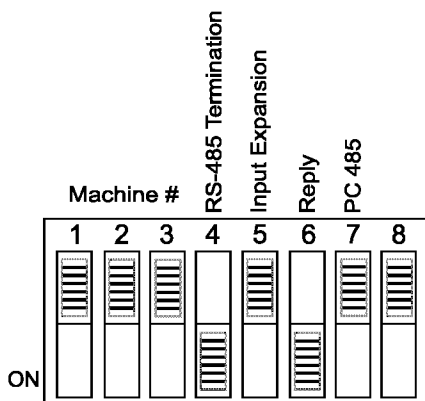

Figure 5: SETUP Set of 8 Dipswitches

Table 4: Dipswitch Settings

Function	DIPS	Description
Machine #	1, 2, 3	Determines the position of a unit in the sequence (refer to section 5.3.1)
RS-485 Termination	4	Set ON to terminate the RS-485 line on the first and last cascaded units (refer to section 6.1)
Input Expansion	5	Set ON to enable input expansion mode (refer to section 6.1)
Reply	6	Set ON to enable the Reply option in accordance with Protocol 2000
PC 485	7	Set ON when connecting the PC (or other controller) via the RS-485 port, set OFF when connecting the PC via the RS-232 port or when not connecting a PC

### 5.3.1 Setting the MACHINE #

The *MACHINE #* determines the position of a **VS-402x1/VS-602x1** unit or a set of **VS-402x1/VS-602x1** units in the sequence<sup>1</sup>, specifying which **VS-402x1/VS-602x1** unit is being controlled when several **VS-402x1/VS-602x1** units connect to a PC or serial controller. Set the *MACHINE #* on a **VS-402x1/VS-602x1** unit via DIPS 1, 2 and 3, according to Table 5.

When using a stand-alone **VS-402x1/VS-602x1** unit, set the *MACHINE #* to 1.

When connecting more than one **VS-402x1/VS-602x1** unit, set the first machine (the Master) that is closest to the PC, as *MACHINE #* 1<sup>2</sup>.

<sup>1</sup> Set the *MACHINE #* on the first unit to one, on the second unit to 2, on the third unit to 3

<sup>2</sup> Set the dipswitches to ON

Table 5: Machine # Dipswitch Settings

MACHINE #	DIPSWITCH		
	1	2	3
1 Master	OFF	OFF	OFF
2	ON	OFF	OFF
3	OFF	ON	OFF
4	ON	ON	OFF
5	OFF	OFF	ON
6	ON	OFF	ON
7	OFF	ON	ON
8	ON	ON	ON

### 5.4 Connecting the REMOTE Connector

Connecting the *REMOTE* DB15F connector to a dry contact switch enables you to route an input to an output by remote control. To do so, touch (momentarily) the PIN corresponding to that input to PIN 9<sup>1</sup> (for output # 2) or PIN 10 (for output # 1). For example, to connect input # 1 to output # 1, touch PIN 1 to PIN 10; to connect input # 2 to output # 1, touch PIN 1 to PIN 10; to connect input # 2 to output # 2, touch PIN 2 to PIN 10. To connect input # 3 to output # 1, touch PIN 3 to PIN 10. To connect input # 1 to output # 2, touch PIN 1 to PIN 9. To connect input # 2 to output # 2, touch PIN 2 to PIN 9.

Switch input # 3 to outputs 1A and 1B, by attaching PIN 3 to PIN 10

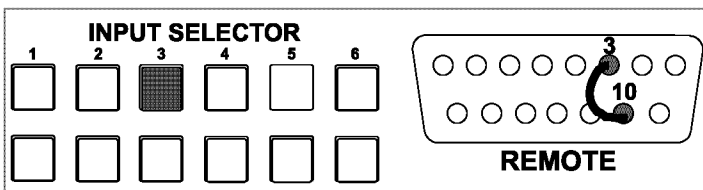

Switch input # 5 to outputs 2A and 2B, by attaching PIN 5 to PIN 9

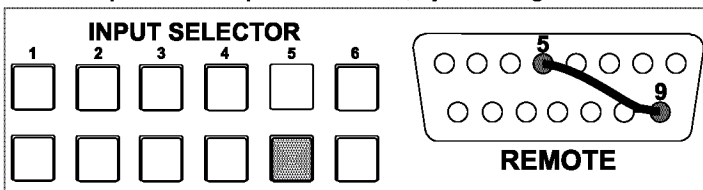

Figure 6: Remote Connector PIN # Settings

<sup>1</sup> The appropriate front panel INPUT SELECTOR button illuminates

## 6 Cascading Vertical Interval Video-Audio Matrix Switchers

For certain applications, you may need more than just 4 or 6 inputs. Cascading **VS-402xl/VS-602xl** units<sup>1</sup> enables you to expand the number of inputs by looping up to 8 individual **VS-402xl/VS-602xl** units.

You can cascade **VS-402xl/VS-602xl** units, as follows:

- Up to 8 interconnected **VS-402xl/VS-602xl** units in an input expansion configuration
- A set of **VS-402xl/VS-602xl** units in a parallel configuration (for example, 2 **VS-402xl/VS-602xl** units for Y/C, 3 **VS-402xl/VS-602xl** units for RGB or YUV, 4 **VS-402xl/VS-602xl** units for RGBS)
- Up to 8 individual **VS-402xl/VS-602xl** units in a control configuration
- Up to 8 interconnected **VS-402xl/VS-602xl** units in an output expansion configuration

### 6.1 Cascading Units in an Input Expansion Configuration

You can cascade up to 8 interconnected **VS-402xl/VS-602xl** units to form an input expansion configuration. For example, to create a 48 x 2 switcher, with 48 inputs and 2 outputs, connect as Figure 7 illustrates.

To cascade **VS-402xl/VS-602xl** units to expand the number of inputs, connect as follows:

1. Connect the composite video sources and acceptors, as well as the appropriate audio sources and acceptors, as section 5 describes.
2. Connect the RS-232 port on the first **VS-402xl/VS-602xl** unit (*MACHINE # 1*) to the PC using the Null-modem adapter provided with the machine (recommended), as section 5.1 describes.
3. Connect the RS-485 terminal block port on the first **VS-402xl/VS-602xl** unit to the RS-485 port on the second **VS-402xl/VS-602xl** unit and so on, connecting all the RS-485 ports, as Figure 7 illustrates.
4. Interconnect the *V/A* (video/audio) *BUS* DB9F connectors between the **VS-402xl/VS-602xl** units<sup>2</sup>, as Figure 7 illustrates, using a 9 wire flat cable<sup>3</sup> with DB9M connectors, as follows:

---

<sup>1</sup> You can interconnect VS-402xl units with VS-602xl units, and you are not limited to cascading VS-602xl units with VS-602xl units. For example, for a 10x2 vertical interval video-audio matrix switcher, interconnect a VS-402xl unit with a VS-602xl unit

<sup>2</sup> Ensuring double output signal transmission on outputs 1A and 1B and on outputs 2A and 2B, on 2 combined machines

<sup>3</sup> The flat cable should be kept as short as possible to preserve video quality and minimize crosstalk

- Attach the cable's first DB9M connector to the *V/A BUS* DB9F connector on the first **VS-402xl/VS-602xl** unit
  - Attach the cable's second DB9M connector to the *V/A BUS* DB9F connector on the second **VS-402xl/VS-602xl** unit
  - Continue attaching the DB9M connectors to the *V/A BUS* DB9F connectors on each **VS-402xl/VS-602xl** unit, up to and including the eighth **VS-402xl/VS-602xl** unit
5. Set the SETUP dipswitches, as section 5.2 describes. In particular:
- Set the first **VS-402xl/VS-602xl** unit as MACHINE # 1 (when operating via a PC or serial controller) and the following 7 **VS-402xl/VS-602xl** units as MACHINE # 2 to MACHINE # 8, according to Table 5
  - Set Dip 4 ON on the first and last **VS-402xl/VS-602xl** units (terminating the RS-485 line at 120  $\Omega$ ). Set Dip 4 OFF on the second to seventh **VS-402xl/VS-602xl** units
  - Set Dip 5 ON on all 8 **VS-402xl/VS-602xl** units (enabling input expansion)
  - Set Dip 6 ON on all 8 **VS-402xl/VS-602xl** units (enabling the Reply option in accordance with Protocol 2000)
  - Set Dip 7 OFF on all 8 **VS-402xl/VS-602xl** units (as the PC connects via the RS-232 port)
  - Set Dip 8 OFF on all 8 **VS-402xl/VS-602xl** units

Note: The output signals at OUTPUT 1 and OUTPUT 2 are the same on all the cascaded **VS-402xl/VS-602xl** units.

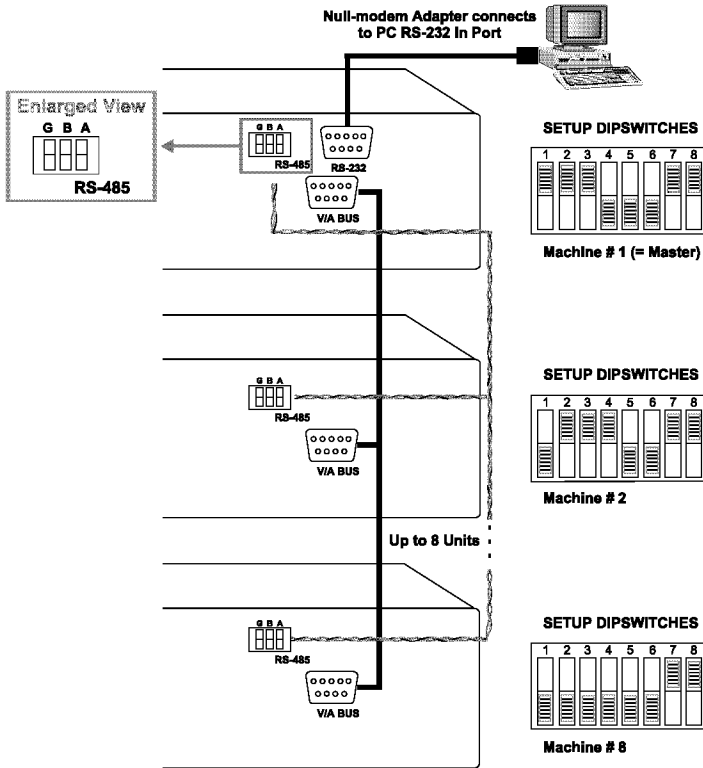

Figure 7: Cascading Units in an Input Expansion Configuration

## 6.2 Cascading a set of Units in a (RGB) Parallel Configuration

You can cascade a set of, for example, 3 VS-602xl units to form a 6x2 RGB vertical interval video-audio matrix switcher in parallel configuration.

To form a 6x2 RGB vertical interval video-audio matrix switcher, do the following:

1. Connect the video sources and acceptors, as well as the appropriate audio sources and acceptors, by reassigning the composite video inputs, 1 to 6, as Figure 8 illustrates, as follows:
  - On the first unit, as  $R_1$  to  $R_6$ ; on the second unit, as  $G_1$  to  $G_6$ ; and on the third unit, as  $B_1$  to  $B_6$ .
2. Connect the RS-232 port on the first VS-602xl unit to the PC (if required) using the Null-modem adapter provided with the machine (recommended), as section 5.1 describes.

3. Connect the RS-485 terminal block port on the first **VS-602x1** unit to the RS-485 port on the second and third **VS-602x1** units.
4. Set the SETUP dipswitches, as section 5.2 describes. In particular:
  - Set all the **VS-602x1** units with the same MACHINE # (preferably, as MACHINE # 1)
  - Set Dip 4 ON on the first and last **VS-602x1** units (terminating the RS-485 line at 120 Ω). Set Dip 4 OFF on the second **VS-602x1** unit
  - Set Dip 5 and Dip 8 OFF on all **VS-602x1** units
  - Set Dip 6 ON on all **VS-602x1** units (enabling the Reply option in accordance with Protocol 2000)
  - Set Dip 7 OFF on all **VS-602x1** units (if the PC connects via the RS-232 port)

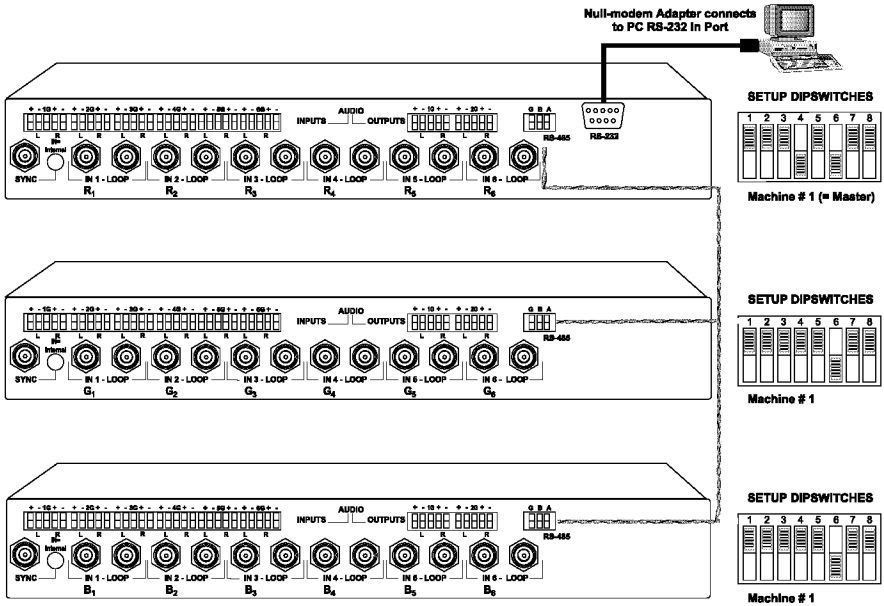

Figure 8: Cascading a set of 3 Units in a (RGB) Parallel Configuration



### 6.3 Cascading Individual Units in a Control Configuration

You can cascade up to 8 individual<sup>1</sup> **VS-402xl/VS-602xl** units with control from a PC or serial controller.

#### 6.3.1 Control Configuration via RS-232 and RS-485

To cascade up to 8 individual **VS-402xl/VS-602xl** units, via RS-232 and RS-485, do the following:

1. Connect the composite video sources and acceptors, as well as the appropriate audio sources and acceptors, as section 5 describes.
2. Connect the RS-232 port on the first **VS-402xl/VS-602xl** unit to the PC using the Null-modem adapter provided with the machine (recommended), as section 5.1 describes.
3. Connect the RS-485 terminal block port on the first **VS-402xl/VS-602xl** unit to the RS-485 port on the second **VS-402xl/VS-602xl** unit and so on, connecting all the RS-485 ports.
4. Set the SETUP dipswitches, as section 5.2 describes. In particular:
  - Set the first **VS-402xl/VS-602xl** unit as MACHINE # 1 and the following 7 **VS-402xl/VS-602xl** units as MACHINE # 2 to MACHINE # 8, according to Table 5
  - Set Dip 4 ON on the first and last **VS-402xl/VS-602xl** units (terminating the RS-485 line at 120  $\Omega$ ). Set Dip 4 OFF on the other **VS-402xl/VS-602xl** units
  - Set Dip 6 ON on all **VS-402xl/VS-602xl** units (enabling the Reply option in accordance with Protocol 2000)
  - Set Dip 5 and Dip 8 OFF on all **VS-402xl/VS-602xl** units
  - Set Dip 7 OFF on all **VS-402xl/VS-602xl** units (if the PC connects via the RS-232 port)

---

<sup>1</sup> But not interconnected

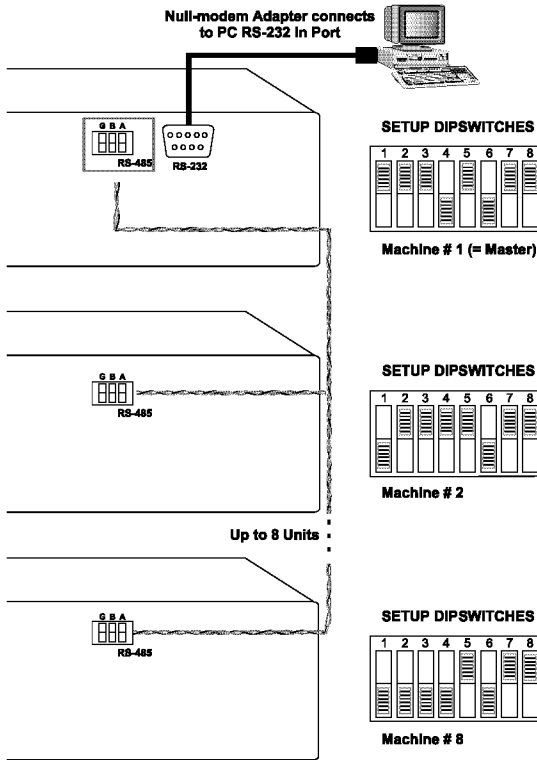

Figure 9: Cascading Individual Units in a Control Configuration via RS 232 and RS 485

### 6.3.2 Control Configuration via RS-485

To cascade up to 8 individual VS-402xl/VS-602xl units, via RS-485 (with control via a Master Programmable Remote Control system such as the Kramer VS-3000), do the following:

1. Connect the composite video sources and acceptors, as well as the appropriate audio sources and acceptors, as section 5 describes.
2. Connect the “A” (+) and “B” (-) PINS on the RS-485 terminal block port of the VS-3000 to the “A” (+) and “B” (-) PINS, respectively, on each of the 8 VS-402xl/VS-602xl units. (If using shielded twisted pair cable, the shield is usually connected to the “G” (Ground) PIN of the first unit).
3. Set the first VS-402xl/VS-602xl unit as MACHINE # 1 and the following 7 VS-402xl/VS-602xl units as MACHINE # 2 to MACHINE # 8, according to Table 5.
4. Set the SETUP dipswitches on the VS-402xl/VS-602xl unit, as follows:

- Set Dip 4 ON on the last unit (terminating the RS-485 line at 120  $\Omega$ ). Set Dip 4 OFF on the other units
- Set Dip 6 ON on all 8 units (enabling the Reply option in accordance with Protocol 2000)
- Set Dip 5 and Dip 8 OFF on all 8 units
- Set Dip 7 ON on all units (as the PC connects via the RS-485 port)

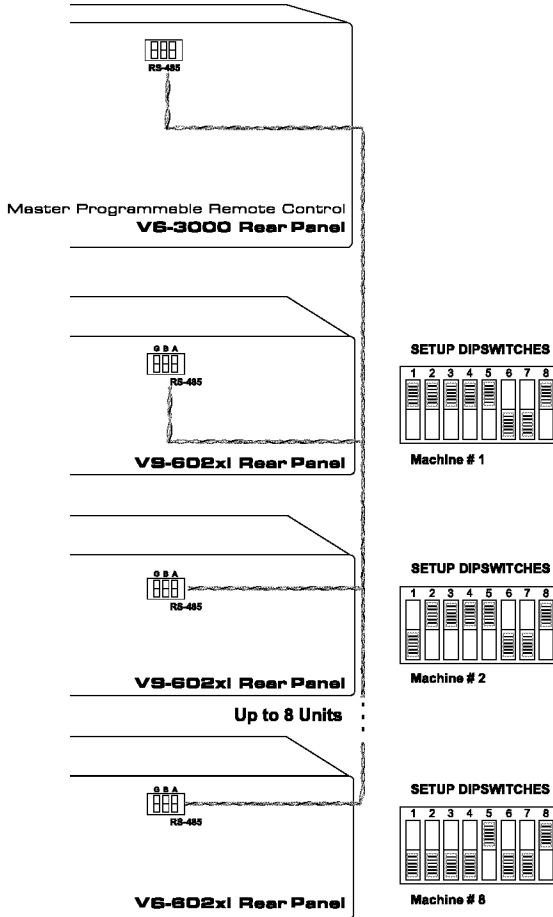

Figure 10: Cascading Individual Units in a Control Configuration via RS 485

## 6.4 Looping Units in an Increased Output Configuration

You can loop up to 8 **VS-402xl/VS-602xl** units to increase outputs.

To form a 6x4 vertical interval video-audio matrix switcher, consisting of 2 VS-602xl units, as Figure 11 illustrates, do the following:

1. Connect the 6 composite video sources to the IN connectors on the second VS-602xl unit.
2. Connect the 6 Loop connectors on the second VS-602xl unit to the respective 6 input connectors on the first VS-602xl unit.
3. Connect the OUTPUTS connectors on both VS-602xl units to the composite video acceptors.

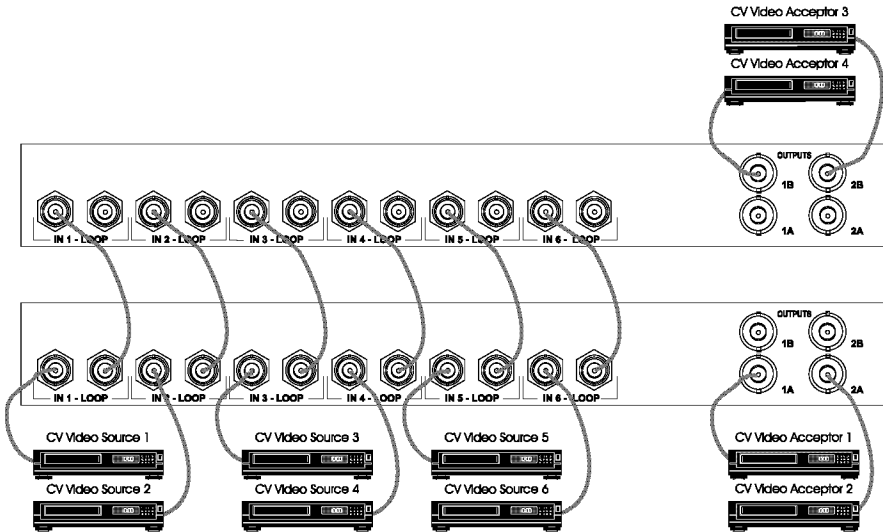

Figure 11: Adding Outputs by Looping Units

## 7 Operating the Vertical Interval Video-Audio Matrix Switcher

You can operate your VS-402xl/VS-602xl via:

- The front panel buttons
- RS-232 (or RS-485<sup>1</sup>) serial commands transmitted by a touch screen system, PC<sup>2</sup>, or other serial controller
- A remote dry contact switch

<sup>1</sup> Set DIP 7 ON on all VS-402xl/VS-602xl units when a PC or touch screen system functions via the RS-485 serial port

<sup>2</sup> For instructions on using the Windows 95/98/NT™ Control Software, refer to the separate user manual (included on the CD-ROM in .pdf format), *Kramer Control Software*

## 7.1 Choosing the Audio-Follow-Video or Breakaway Option

You can switch stereo audio signals in one of 2 ways, either:

- Audio-follow-video (AFV), in which all operations relate to both the video and the audio channels; or
- Breakaway, in which video and audio channels switch independently

### 7.1.1 Setting the Audio-Follow-Video Option

To set the Audio-follow-video (AFV) option, when the AUDIO and VIDEO configurations are the same:

- Press the AFV button

The AFV<sup>1</sup> button illuminates. The audio will follow the video

To set the Audio-follow-video (AFV) option, when the AUDIO configuration differs from the VIDEO configuration:

- Press the AFV button

The TAKE and the AUDIO buttons flash<sup>2</sup>, even when working in the *AT ONCE* mode<sup>3</sup>

- Press the TAKE button to confirm the modification. The audio will follow the video

### 7.1.2 Setting the Breakaway Option

To set the Breakaway option:

1. Press either the AUDIO (for audio control only) or the VIDEO (for video control only) button.
2. If the AUDIO button illuminates, switching operations relate to Audio.
3. If the VIDEO button illuminates, switching operations relate to Video.

## 8 Technical Specifications

Table 6 includes the technical specifications:

---

1 When cascading units in an input expansion configuration or RGB(H) mode, as section 6.1 describes, pressing the front panel AFV button on one interconnected VS-402xl/VS-602xl unit also illuminates the AFV button on the other VS-402xl/VS-602xl units. However, pressing the VIDEO or AUDIO button on an interconnected VS-402xl/VS-602xl unit does not illuminate the corresponding VIDEO or AUDIO buttons on the other VS-402xl/VS-602xl units.

2 Warning that you are about to modify the audio configuration for AFV operation

3 Refer to item 7 in Table 1

## Table of Hex Codes for Serial Communication

*Table 6: Technical Specifications of the Vertical Interval Video Audio Matrix Switcher*

Inputs	6 (4) composite video with loops, 1 Sync - 1Vpp/75 Ω on BNCs with sync select switch 6 (4) balanced audio stereo, +4 dBm/33 kΩ on detachable terminal blocks
Outputs	2 composite video with loops -1Vpp/75 Ω on BNCs 2 balanced audio stereo, +4 dBm/50 Ω on detachable terminal blocks
Video Bandwidth	> 300 MHz
Audio Bandwidth	100 kHz
S/N Ratio	Video 77 dB; Audio 82 dB unweighted, (1Vpp)
Diff. Gain	0.03%
Diff. Phase	0.01 Deg
K-Factor	<0.05%
Crosstalk	Video - < -67 dB @ 5MHz; Audio -97 dB @ 1kHz
Control	17 (13) illuminated front-panel selector buttons, RS-232, RS-485
Max Output	Audio output 24 Vpp max
Coupling	Video - DC; Audio - DC
Audio THD	0.024%
Audio 2nd Harmonic	0.001%
Dimensions	19-inch (W), 7-inch (D) 1U (H) rack-mountable
Power Source	Universal, 100-120, 200-240 VAC, 50-60 Hz, 40W max
Weight	2.7 kg (6 lbs.) approx.
Accessories	Power cord, PC control software

## 9 Table of Hex Codes for Serial Communication

Table 7 lists the Hex values for a single machine (*MACHINE # 1*):

*Table 7: VS 402xl/VS 602xl Hex Codes for Switching via RS 232/RS 485*

	Switching Video Channels		Switching Audio Channels	
	OUT 1	OUT 2	OUT 1	OUT 2
IN 1	01	01	02	02
	81	81	81	81
	81	82	81	82
	81	81	81	81
IN 2	01	01	02	02
	82	82	82	82
	81	82	81	82
	81	81	81	81
IN 3	01	01	02	02
	83	83	83	83
	81	82	81	82
	81	81	81	81
IN 4	01	01	02	02
	84	84	84	84
	81	82	81	82
	81	81	81	81
IN 5	01	01	02	02
	85	85	85	85
	81	82	81	82
	81	81	81	81
IN 6	01	01	02	02
	86	86	86	86
	81	82	81	82
	81	81	81	81

## 10 Communication Protocol

This protocol, which enables RS-232 communication between the **VS-402x1/VS-602x1** and the PC, uses 4 bytes of information, and data is at 9600 baud, no parity, 8 data bits and 1 stop bit.

*Table 8: Protocol Definitions*

MSB							LSB	
	DESTINATION	INSTRUCTION						
0	D	N5	N4	N3	N2	N1	N0	
7	6	5	4	3	2	1	0	
1st byte								
	INPUT							
1	I6	I5	I4	I3	I2	I1	I0	
7	6	5	4	3	2	1	0	
2nd byte								
	OUTPUT							
1	O	O	O	O	O	O1	O0	
7	6	5	4	3	2	1	0	
3rd byte								
	MACHINE NUMBER							
1	M	M	M	M3	M2	M1	M0	
7	6	5	4	3	2	1	0	
4th byte								

1st BYTE: Bit 7 – Defined as 0.

D – “DESTINATION”: 0 - for sending information to the switchers (from the PC);

1 - for sending to the PC (from the switcher).

N5...N0 – “INSTRUCTION”

The function that is to be performed by the switcher(s) is defined by the INSTRUCTION (6 bits). Similarly, if a function is performed via the machine’s keyboard, then these bits are set with the INSTRUCTION NO., which was performed. The instruction codes are defined according to the table below (INSTRUCTION NO. is the value to be set for N5...N0).

2nd BYTE: Bit 7 – Defined as 1.

I6...I0 – “INPUT”.

When switching (ie. instruction codes 1 and 2), the INPUT (7 bits) is set as the input number which is to be switched. Similarly, if switching is done via the machine’s front-panel, then these bits are set with the INPUT NUMBER which was switched. For other operations, these bits are defined according to the table.

3rd BYTE: Bit 7 – Defined as 1.

O6...O0 – “OUTPUT”.

When switching (ie. instruction codes 1 and 2), the OUTPUT (7 bits) is set as the output number which is to be switched. Similarly, if switching is done via the machine’s front-panel, then these bits are set with the OUTPUT NUMBER which was switched. For other operations, these bits are defined according to the table.

4th BYTE: Bit 7 – Defined as 1.

Bit 5 – Don’t care.

OVR – Machine number override.

M4...M0 – MACHINE NUMBER.

Used to address machines in a system via their machine numbers. When several machines are controlled from a single serial port, they are usually configured together with each machine having an individual machine number. If the OVR bit is set, then all machine numbers will accept (implement) the command, and the addressed machine will reply.

For a single machine controlled via the serial port, always set M4...M0 = 1, and make sure that the machine itself is configured as MACHINE NUMBER = 1.

Table 9: Instruction Codes

INSTRUCTION		DEFINITION FOR SPECIFIC INSTRUCTION		NOTE
#	DESCRIPTION	INPUT	OUTPUT	
0	RESET VIDEO	0	0	1
1	SWITCH VIDEO	Set equal to video input which is to be switched (0 = disconnect)	Set equal to video output which is to be switched (0 = to all the outputs)	2
2	SWITCH AUDIO	Set equal to audio input which is to be switched (0 = disconnect)	Set equal to audio output which is to be switched (0 = to all the outputs)	2
5	REQUEST STATUS OF A VIDEO OUTPUT	Set as SETUP # 0	Equal to output number whose status is reqd	4, 3
6	REQUEST STATUS OF AN AUDIO OUTPUT	Set as SETUP # 0	Equal to output number whose status is reqd	4, 3
8	BREAKAWAY SETTING	0	0 - audio-follow-video 1 - audio breakaway	2
11	REQUEST BREAKAWAY SETTING	Set as SETUP # 0, or set to 126 or 127 to request if machine has this function	0 - Request audio breakaway setting	3, 4, 6
12	REQUEST VIDEO / AUDIO TYPE SETTING	Set as SETUP # 0, or set to 126 or 127 to request if machine has this function	0 - for video 1 - for audio	3, 4, 6
16	ERROR / BUSY	0	0 - error 1 - invalid instruction 2 - out of range	9
18	RESET AUDIO	0	0	1
30	LOCK FRONT PANEL	0 - Panel unlocked 1 - Panel locked	0	2
31	REQUEST WHETHER PANEL IS LOCKED	0	0	16
57	SET AUTO-SAVE	0 - no save 1 - auto-save	0	12, 2
61	IDENTIFY MACHINE	1 - video machine name 2 - audio machine name 3 - video software version 4 - audio software version	0	13
62	DEFINE MACHINE	1 - number of inputs 2 - number of outputs 3 - number of setups	1 - for video 2 - for audio	14

NOTES on the above table:

**NOTE 1** - When the master switcher is reset, (e.g. when it is turned on), the reset code is sent to the PC. If this code is sent to the switchers, it will reset according to the present power-down settings.

**NOTE 2** - These are bi-directional definitions. That is, if the switcher receives the code, it will perform the instruction; and if the instruction is performed (due to a keystroke operation on the front panel), then these codes are sent. For example, if the HEX code

01            85            88            83

was sent from the PC, then the switcher (machine 3) will switch input 5 to output 8. If the user switched input 1 to output 7 via the front panel keypad, then the switcher will send:

41            81            87            83

to the PC.

When the PC sends one of the commands in this group to the switcher, then, if the instruction is valid, the switcher replies by sending to the PC the same four bytes that it was sent (except for the first byte, where the DESTINATION bit is set high).

**NOTE 3** - SETUP # 0 is the present setting. SETUP # 1 to SETUP # 15 are the settings saved in the switcher's memory, (i.e. those used for Store and Recall).

**NOTE 4** - The reply to a "REQUEST" instruction is as follows: the same instruction and INPUT codes as were sent are returned, and the OUTPUT is assigned the value of the requested parameter. The replies to instructions 10 and 11 are as per



the definitions in instructions 7 and 8 respectively. For example, if the present status of machine number 5 is breakaway setting, then the reply to the HEX code

0B        80        80        85

would be

4B        80        81        85

**NOTE 5** – For the OUTPUT byte set as 6, the VIS source is the input selected using the OUTPUT byte. Similarly, for the OUTPUT byte set as 7, the VIS source is the output selected using the OUTPUT byte. Note also, that on some machines the sync source is not software selectable, but is selected using switches, jumpers, etc!

**NOTE 6** – If INPUT is set to 127 for these instructions, then, if the function is defined on this machine, it replies with OUTPUT=1. If the function is not defined, then the machine replies with OUTPUT=0, or with an error (invalid instruction code), or will not reply.

If the INPUT is set to 126 for these instructions, then, if possible, the machine will return the current setting of this function, even for the case that the function is not defined. For example, for a video switcher which always switches during the VIS of input #1, (and its VIS setting cannot be programmed otherwise), the reply to the HEX code

4A        FE        80        81 (ie. request VIS setting, with INPUT set as 126dec)

would be

4A        FE        81        81 (ie. VIS setting = 1, which is defined as VIS from input #1).

**NOTE 7** – Setting OUTPUT to 0 will return the VIS source setting as defined in instruction #7. Setting to 1 will return the input # or output # of the sync source (for the case where the VIS source is set as 6 or as 7 in instruction #7). Setting to 2 returns the vertical sync frequency (0 for no input sync, 50 for PAL, 60 for NTSC, 127 for error).

**NOTE 8** - The reply to the "REQUEST WHETHER SETUP IS DEFINED" is as in TYPE 3 above, except that here the OUTPUT is assigned with the value 0 if the setup is not defined; or 1 if it is defined.

**NOTE 9** - An error code is returned to the PC if an invalid instruction code was sent to the switcher, or if a parameter associated with the instruction is out of range (e.g. trying to save to a setup greater than 15, or trying to switch an input or output greater than the highest one defined). This code is also returned to the PC if an RS-232 instruction is sent while the machine is being programmed via the front panel. Reception of this code by the switcher is not valid.

**NOTE 10** – This code is reserved for internal use.

**NOTE 11** – For machines where the video and / or audio gain is programmable. The value of the gain is represented in twos complement form to allow for negative values (attenuation).

**NOTE 12** - Under normal conditions, the machine's present status is saved each time a change is made. The "power-down" save (auto-save) may be disabled using this code. Note that whenever the machine is turned on, the auto -save function is set.

**NOTE 13** - This is a request to identify the switcher/s in the system. If the INPUT is set as 1 or 2, the machine will send its name. The reply is the decimal value of the INPUT and OUTPUT. For example, for a 2216, the reply to the request to send the audio machine name would be (HEX codes):

7D        96        90        81 (i.e. 128dec+ 22dec for 2nd byte, and 128dec+ 16dec for 3rd byte).

If the request for identification is sent with the INPUT set as 3 or 4, the appropriate machine will send its software version number. Again, the reply would be the decimal value of the INPUT and OUTPUT - the INPUT representing the number in front of the decimal point, and the OUTPUT representing the number after it. For example, for version 3.5, the reply to the request to send the version number would be (HEX codes):

7D        83        85        81 (i.e. 128dec+ 3dec for 2nd byte, 128dec+ 5dec for 3rd byte).

**NOTE 14** - The number of inputs and outputs refers to the specific machine which is being addressed, not to the system. For example, if six 16X16 matrices are configured to make a 48X32 system (48 inputs, 32 outputs), the reply to the HEX code

3E        82        81        82 (ie. request the number of outputs)

would be

7E        82        90        82

ie. 16 outputs

**NOTE 16** - The reply to the "REQUEST WHETHER PANEL IS LOCKED" is as NOTE 4 above, except that here the OUTPUT is assigned with the value 0 if the panel is unlocked, or 1 if it is locked.

---

## LIMITED WARRANTY

Kramer Electronics (hereafter *Kramer*) warrants this product free from defects in material and workmanship under the following terms.

### HOW LONG IS THE WARRANTY

Labor and parts are warranted for three years from the date of the first customer purchase.

### WHO IS PROTECTED?

Only the first purchase customer may enforce this warranty.

### WHAT IS COVERED AND WHAT IS NOT COVERED

Except as below, this warranty covers all defects in material or workmanship in this product. The following are not covered by the warranty:

1. Any product which is not distributed by Kramer, or which is not purchased from an authorized Kramer dealer. If you are uncertain as to whether a dealer is authorized, please contact Kramer at one of the agents listed in the web site [www.kramerelectronics.com](http://www.kramerelectronics.com).
2. Any product, on which the serial number has been defaced, modified or removed.
3. Damage, deterioration or malfunction resulting from:
  - i) Accident, misuse, abuse, neglect, fire, water, lightning or other acts of nature
  - ii) Product modification, or failure to follow instructions supplied with the product
  - iii) Repair or attempted repair by anyone not authorized by Kramer
  - iv) Any shipment of the product (claims must be presented to the carrier)
  - v) Removal or installation of the product
  - vi) Any other cause, which does not relate to a product defect
  - vii) Cartons, equipment enclosures, cables or accessories used in conjunction with the product

### WHAT WE WILL PAY FOR AND WHAT WE WILL NOT PAY FOR

We will pay labor and material expenses for covered items. We will not pay for the following:

1. Removal or installations charges.
2. Costs of initial technical adjustments (set-up), including adjustment of user controls or programming. These costs are the responsibility of the Kramer dealer from whom the product was purchased.
3. Shipping charges.

### HOW YOU CAN GET WARRANTY SERVICE

1. To obtain service on your product, you must take or ship it prepaid to any authorized Kramer service center.
2. Whenever warranty service is required, the original dated invoice (or a copy) must be presented as proof of warranty coverage, and should be included in any shipment of the product. Please also include in any mailing a contact name, company, address, and a description of the problem(s).
3. For the name of the nearest Kramer authorized service center, consult your authorized dealer.

### LIMITATION OF IMPLIED WARRANTIES

All implied warranties, including warranties of merchantability and fitness for a particular purpose, are limited in duration to the length of this warranty.

### EXCLUSION OF DAMAGES

The liability of Kramer for any effective products is limited to the repair or replacement of the product at our option. Kramer shall not be liable for:

1. Damage to other property caused by defects in this product, damages based upon inconvenience, loss of use of the product, loss of time, commercial loss; or
2. Any other damages, whether incidental, consequential or otherwise. Some countries may not allow limitations on how long an implied warranty lasts and/or do not allow the exclusion or limitation of incidental or consequential damages, so the above limitations and exclusions may not apply to you.

This warranty gives you specific legal rights, and you may also have other rights, which vary from place to place.

**NOTE:** All products returned to Kramer for service must have prior approval. This may be obtained from your dealer.

This equipment has been tested to determine compliance with the requirements of:

- EN-50081: "Electromagnetic compatibility (EMC);  
generic emission standard.  
Part 1: Residential, commercial and light industry"
- EN-50082: "Electromagnetic compatibility (EMC) generic immunity standard.  
Part 1: Residential, commercial and light industry environment".
- CFR-47: FCC Rules and Regulations:  
Part 15: "Radio frequency devices  
Subpart B – Unintentional radiators"

### CAUTION!

- ☒ Servicing the machines can only be done by an authorized Kramer technician. Any user who makes changes or modifications to the unit without the expressed approval of the manufacturer will void user authority to operate the equipment.
- ☒ Use the supplied DC power supply to feed power to the machine.
- ☒ Please use recommended interconnection cables to connect the machine to other components.



**The list of Kramer distributors appears on our web site:  
[www.kramerelectronics.com](http://www.kramerelectronics.com)**

**We welcome your questions, comments and feedback.**

---

**Kramer Electronics, Ltd.**

3 Am VeOlamo Street. Jerusalem 95463, Israel Tel: (+972-2)-654-4000

Fax: (+972-2)-653-5369, E-mail: [kramere1@netvision.net.il](mailto:kramere1@netvision.net.il)

**P/N: 2900 – 002022 REV 1**