

Kramer Electronics, Ltd.



USER MANUAL

Model:

VM-114H

2x Input 1:4 HDMI DA

Contents

1	Introduction	1
2	Getting Started	1
2.1	Achieving the Best Performance	1
2.2	Safety Instructions	2
2.3	Recycling Kramer Products	2
2.4	Quick Start	2
3	Overview	3
3.1	Using Shielded Twisted Pair Cable	4
3.2	About the Power Connect™ Feature	5
4	Defining the VM-114H 2 Input 1:4 HDMI DA	6
5	Using the VM-114H 2 Input 1:4 HDMI DA	7
5.1	Connecting the VM-114H 2 Input 1:4 HDMI DA	7
5.2	Selecting an Active Input	8
5.3	Acquiring the EDID	8
5.3.1	Disabling/Enabling Deep Color Support	9
5.4	Connecting to the VM-114H via RS-232	10
6	Wiring the Twisted Pair RJ-45 Connectors	10
7	Technical Specifications	11
8	Default Communication Parameters	11
9	Default EDID	12
10	Kramer Protocol 2000	13

Figures

Figure 1: VM-114H 2 Input 1:4 HDMI DA Front and Rear Panels	6
Figure 2: Connecting the VM-114H 2 Input 1:4 HDMI DA	8
Figure 3: TP Pinout Wiring	10

Tables

Table 1: VM-114H 2 Input 1:4 HDMI DA Front and Rear Panel Features	6
Table 2: Technical Specifications of the VM-114H	11
Table 3: Default Communication Parameters	11
Table 4: Protocol Definitions	13
Table 5: Instruction Codes for Protocol 2000	14

1 Introduction

Welcome to Kramer Electronics! Since 1981, Kramer Electronics has been providing a world of unique, creative and affordable solutions to the vast range of problems that confront the video, audio, presentation and broadcasting professional on a daily basis. In recent years, we have redesigned and upgraded most of our line, making the best even better! Our 1,000-plus different models now appear in 11 groups¹ that are clearly defined by function.

Congratulations on purchasing your Kramer **VM-114H 2 Input 1:4 HDMI DA**. The **VM-114H** is ideal for:

- Home theater, presentation and multimedia applications
- Rental and staging

The package includes the following items:

- **VM-114H 2 Input 1:4 HDMI DA**
- Power adapter (12V DC)
- Kramer **RC-IR3** infrared remote control transmitter (including the required batteries and a separate user manual²)
- This user manual²

2 Getting Started

We recommend that you:

- Unpack the equipment carefully and save the original box and packaging materials for possible future shipment
- Do not secure the cables in tight bundles or roll the slack into tight coils
- Review the contents of this user manual

2.1 Achieving the Best Performance

To achieve the best performance:

- Use only good quality connection cables (we recommend Kramer high-performance, high-resolution cables) to avoid interference, deterioration in signal quality due to poor matching, and elevated noise levels (often associated with low quality cables)

1 GROUP 1: Distribution Amplifiers; GROUP 2: Switchers and Routers; GROUP 3: Control Systems; GROUP 4: Format/Standards Converters; GROUP 5: Range Extenders and Repeaters; GROUP 6: Specialty AV Products; GROUP 7: Scan Converters and Scalers; GROUP 8: Cables and Connectors; GROUP 9: Room Connectivity; GROUP 10: Accessories and Rack Adapters; GROUP 11: Sierra Products

2 Download up-to-date Kramer user manuals from <http://www.kramerelectronics.com>

- Do not secure the cables in tight bundles or roll the slack into tight coils
- Avoid interference from neighboring electrical appliances that may adversely influence signal quality
- Position your Kramer **VM-114H** away from moisture, excessive sunlight and dust



This equipment is to be used only inside a building. It may be connected only to other equipment that is installed inside a building.

2.2 Safety Instructions



Caution: No operator serviceable parts inside the unit

Warning: Use only the Kramer Electronics input power wall adapter that is provided with the unit.

Warning: Disconnect the power and unplug the unit from the wall before installing

2.3 Recycling Kramer Products

The Waste Electrical and Electronic Equipment (WEEE) Directive 2002/96/EC aims to reduce the amount of WEEE sent for disposal to landfill or incineration by requiring it to be collected and recycled. To comply with the WEEE Directive, Kramer Electronics has made arrangements with the European Advanced Recycling Network (EARN) and will cover any costs of treatment, recycling and recovery of waste Kramer Electronics branded equipment on arrival at the EARN facility. For details of Kramer's recycling arrangements in your particular country go to our recycling pages at <http://www.kramerelectronics.com/support/recycling/>.

2.4 Quick Start

This quick start chart summarizes the basic setup and operation steps of the **VM-114H**.

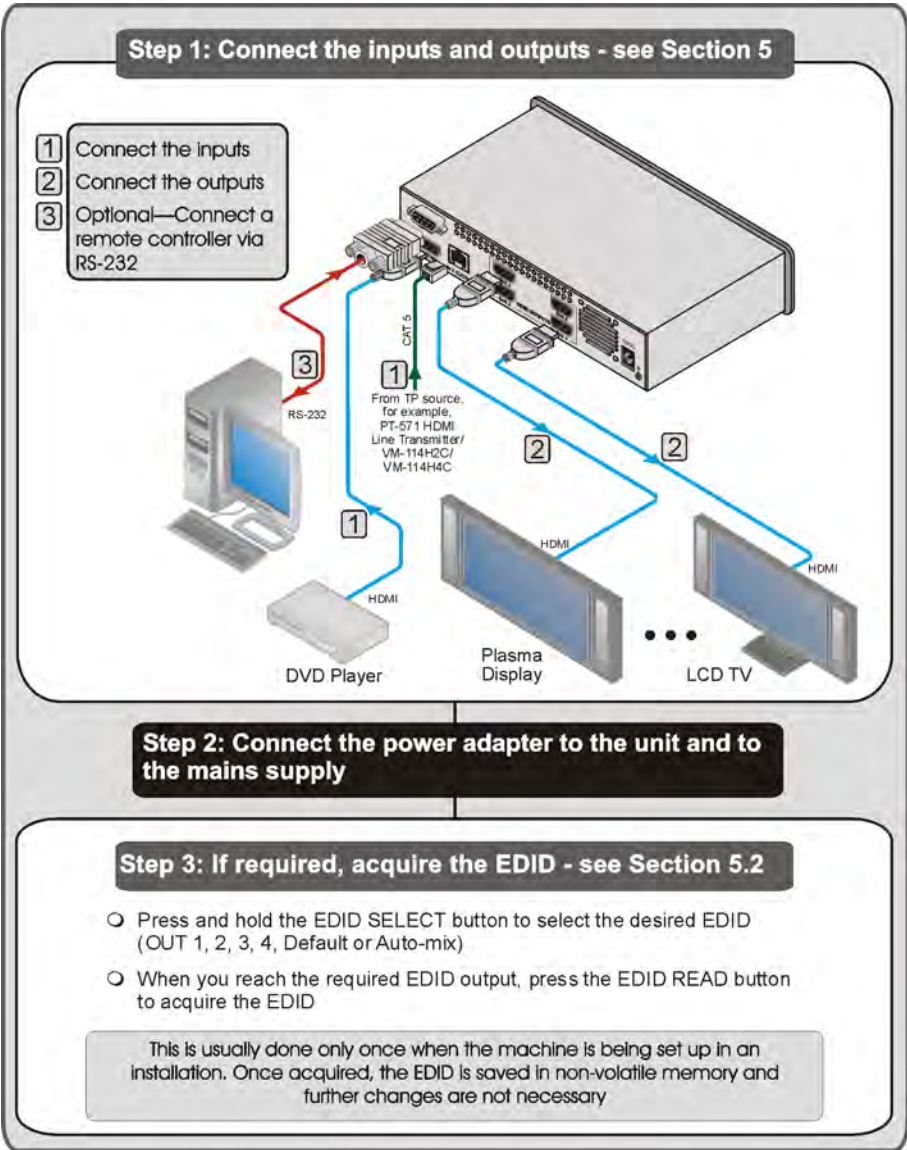

3 Overview

The high quality **VM-114H 2 Input 1:4 HDMI DA** is a switcher/distribution amplifier for HDMI and TP (Twisted Pair) signals. It reclocks and equalizes one of two selectable input signals and distributes it to four identical HDMI outputs.

In particular, the **VM-114H**:

- Has a maximum data rate of 2.25Gbps bandwidth per graphic channel (HDMI), 1.65Gbps bandwidth per graphic channel (DGKat)
- Can read and store, in non-volatile memory, the default EDID, or the EDID¹ block from one or a mix² of the output display devices, so it can then provide the EDID information to the source even if the display device is not connected
- Features I-EDIDPro™ Kramer Intelligent EDID Processing™ – Intelligent EDID handling & processing algorithm ensures Plug and Play operation for HDMI systems
- Supports 3D Pass-through, Deep Color³, x.v.Color™ and uncompressed audio channels (Dolby TrueHD, DTS-HD)
- Is HDCP compliant
- Features LEDs indicating the selected input and active output
- Supports IR remote control
- Is 12V DC fed and is housed in a Kramer desktop enclosure

The **VM-114H** supports a range of:

- Up to 90m (295ft) at 1080i, or up to 30m (98ft) at 1080p on shielded **BC-DGKat524** cable
- Up to 90m (295ft) at 1080i, or up to 70m (230ft) at 1080p on shielded **BC-DGKat623** cable
- Up to 100m (330ft) at 1080i or up to 90m (295ft) at 1080p on shielded **BC-DGKat7a23** cable

You can daisy-chain up to six devices with the maximum overall distance between the first and last devices being cumulative and limited by the cable type used.

3.1 Using Shielded Twisted Pair Cable

Kramer engineers have developed special twisted pair cables to best match our digital twisted pair products; the Kramer: **BC-DGKat524** (CAT 5 24 AWG), the Kramer **BC-DGKat623** (CAT 6 23 AWG), and the Kramer **BC-DGKat7a23** (CAT 7a 23 AWG) cables. These specially built cables significantly outperform regular CAT 5/CAT 6 /CAT 7a cables.

¹ EDID is Extended Display Identification Data (see [Section 3.3](#) for a more detailed definition)

² The EDID acquired is a weighted average of all the connected outputs. For example, if several displays with different resolutions are connected to the outputs, the acquired EDID supports all the resolutions, as well as other parameters included in the EDID

³ On the HDMI input

3.2 About the Power Connect™ Feature

The Power Connect™ feature here means that only the transmitter needs to be connected to a power source when the devices are within 90m (270ft) of each other. The Power Connect™ feature applies as long as the cable can carry power. The distance does not exceed 90m on standard CAT 5 cable. For longer distances, heavier gauge cable should be used¹.



Warning: Using a TP cable that is incorrectly wired will cause permanent damage to the device

¹ CAT 5 cable is still suitable for the video/audio transmission, but not for feeding the power at these distances

4 Defining the VM-114H 2 Input 1:4 HDMI DA

[Figure 1](#) and [Table 1](#) define the front and rear panels of the VM-114H 2 Input 1:4 HDMI DA.

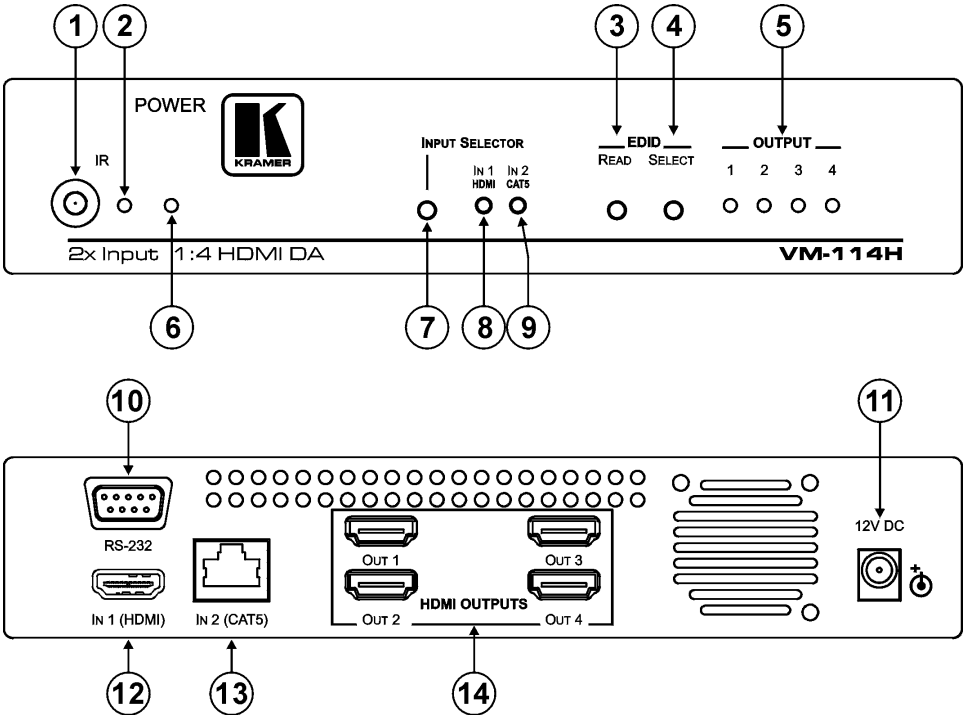

Figure 1: VM-114H 2 Input 1:4 HDMI DA Front and Rear Panels

Table 1: VM-114H 2 Input 1:4 HDMI DA Front and Rear Panel Features

#	Feature	Function	
1	IR Remote Control Sensor	Sensor for the remote control IR transmitter	
2	IR LED	Lights yellow when receiving signals from the IR remote control transmitter	
3	EDID Buttons	READ Button	Press (when one of the input LEDs is flashing to indicate a selected input) to read the selected EDID (see Section 5.2)
		SELECT Button	Press repeatedly to cycle through the inputs to select an input from which to read the EDID. The relevant LED flashes (see Section 5.2)
5	OUTPUT 1~4 LEDS	The relevant LED lights green when an acceptor is connected to the output ¹	
6	POWER LED	Lights green when he unit receives power	
7	INPUT SELECTOR Button	Press to select an input. The relevant input LED lights	
8	IN1 HDMI LED	Input	Lights green when he HDMI input 1 is selected

¹ Also lights or flashes during EDID setup (see [Section 5.2](#))

#	Feature	Function	
9	IN2 CAT5 LED	LEDs	
		Lights green when the TP CAT 5 input 2 is selected	
10	RS-232 9-pin D-sub (F) Connector	Connect to a PC or remote controller	
11	12V DC Power Connector	Connect to the +12V DC power adapter, center pin positive	
12	IN1 (HDMI) Input HDMI Connector	Inputs	
			Connect to an HDMI source
13	IN2 (CAT5) Input RJ-45 Connector	Connect to a TP CAT 5 source (for example, PT-571 HDMI Line Transmitter, VM-114H2C or VM-114H4C)	
14	HDMI OUTPUTS	OUT 1	Connect to the HDMI acceptors
		OUT 2	
		OUT 3	
		OUT 4	

5 Using the VM-114H 2 Input 1:4 HDMI DA

This section describes how to connect the **VM-114H** (see [Section 5.1](#)), how to acquire the EDID (see [Section 5.2](#)) and how to connect via RS-232 (see [Section 5.4](#)).

5.1 Connecting the VM-114H 2 Input 1:4 HDMI DA

To connect¹ the **VM-114H** as illustrated in the example in [Figure 2](#):

1. Connect the HDMI source (for example, a DVD player) to the IN 1 (HDMI) connector.
2. Connect the CAT 5 TP source (for example, a **PT-571 HDMI Line Transmitter, VM-114H2C or VM-114H4C**) to the IN 2 (CAT5) connector.
3. Connect the HDMI OUT connectors to up to four HDMI display devices (for example, plasma displays or LCD TVs)
4. (Optional) Connect a PC via RS-232 to the RS-232 port on the **VM-114H** (see [Section 5.4](#)).
5. Connect the power adapter to the power socket on the **VM-114H** and to the mains electricity.
6. (Optional) Press the EDID READ button to acquire or change the EDID information (see [Section 5.2](#)).

¹ Switch OFF the power on each device before connecting it to your VM-114H. After connecting your VM-114H, switch on its power and then switch on the power on each device

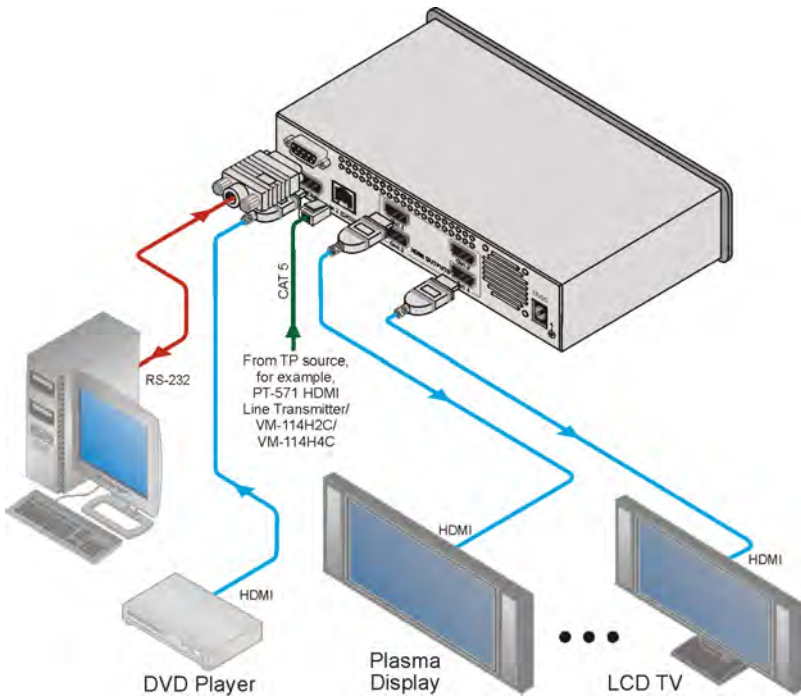

Figure 2: Connecting the VM-114H 2 Input 1:4 HDMI DA

5.2 Selecting an Active Input

To select an active input:

- Press the INPUT SELECTOR button until the required INPUT LED lights

5.3 Acquiring the EDID

Each input on the **VM-114H** has a factory default EDID loaded¹ (see [Section 8](#)). This lets you connect the power before having to connect one of the acceptors.

You can acquire the EDID² from:

- One output (the relevant output LED flashes)
- The default EDID (all output LEDs flash)
- Up to four connected outputs using the Auto-mix Mode¹ (all output LEDs light)

1 The VM-114H reads the EDID which is stored in the non-volatile memory

2 This is usually done only once when the machine is being set up in an installation. Once acquired, the EDID is saved in non-volatile memory and further acquisition is not necessary

To acquire the EDID:

1. Connect the output(s) from which you want to acquire the EDID.
2. Press the EDID SELECT button briefly.
The device enters the EDID programming mode. The last acquired EDID is indicated by the lit LED (for example, if Output LED 2 is lit, the EDID acquired was from Output 2).
3. Press the EDID SELECT button repeatedly until the required EDID is indicated based on the patterns described above.
4. Press the EDID READ button.
The relevant LEDs flash in a pattern for a few seconds as follows:
 - Slowly and then no longer lights. The EDID was successfully read.
 - Quickly and then no longer lights. The EDID was not read and the default EDID was stored.

5.3.1 Disabling/Enabling Deep Color Support

You can disable EDID deep color support to prevent signal deterioration when using long twisted pair cables on INPUT 2.

To disable deep color and acquire EDID:

1. Disconnect the power.
2. Connect the output or outputs from which you want to acquire the EDID.
3. Connect the power while pressing the EDID READ button.
4. Perform steps 3 through 5 in [Section 5.3](#).

To enable deep color and acquire EDID:

1. Disconnect the power.
2. Connect the output or outputs from which you want to acquire the EDID.
3. Connect the power while pressing the EDID SELECT button.
4. Perform steps 3 through 5 in [Section 5.3](#).

¹ The EDID acquired is a weighted average of all the connected outputs. For example, if several displays with different resolutions are connected to the outputs, the acquired EDID supports all the resolutions, as well as other parameters included in the EDID

5.4 Connecting to the VM-114H via RS-232

You can connect to the **VM-114H** via an RS-232 connection using, for example, a PC. Note that a null-modem adapter/connection is not required.

To connect to the VM-114H via RS-232:

- Connect the RS-232 9-pin D-sub rear panel port on the product unit via a 9-wire straight cable (only pin 2 to pin 2, pin 3 to pin 3, and pin 5 to pin 5 need to be connected) to the RS-232 9-pin D-sub port on your PC

6 Wiring the Twisted Pair RJ-45 Connectors

When using STP cable, connect/solder the cable shield to the RJ-45 connector shield. [Figure 3](#) defines the TP pinout using a straight pin-to-pin cable with RJ-45 connectors.



Note, that the cable Ground shielding must be connected/soldered to the connector shield.

EIA /TIA 568B	
PIN	Wire Color
1	Orange / White
2	Orange
3	Green / White
4	Blue
5	Blue / White
6	Green
7	Brown / White
8	Brown
Pair 1	4 and 5
Pair 2	1 and 2
Pair 3	3 and 6
Pair 4	7 and 8

Figure 3: TP Pinout Wiring



7 Technical Specifications

[Table 2](#) includes the technical specifications¹ of the **VM-114H**.

Table 2: Technical Specifications of the VM-114H

INPUTS:	1 HDMI Connector 1 CAT 5 RJ-45 Connector
OUTPUTS:	4 HDMI Connectors
BANDWIDTH:	Up to 2.25Gbps bandwidth per graphic channel (HDMI), 1.65Gbps bandwidth per graphic channel (DGKat)
COMPLIANCE WITH HDMI STANDARD:	Supports HDMI and HDCP
CONTROLS:	Input select button, EDID select button, panel lock button
INDICATOR LEDs:	IR communication, Power, IN 1(HDMI), IN 2 (CAT5), OUTPUT 1, 2, 3 and 4
POWER CONSUMPTION:	12V DC, 0.5A
OPERATING TEMPERATURE:	0° to +40°C (32° to 104°F)
STORAGE TEMPERATURE:	-40° to +70°C (-40° to 158°F)
HUMIDITY:	10% to 90%, RHL non-condensing
D MENSIONS:	21.5cm x 16.3cm x 4.4cm (8.5in x 6.4in x 1.7in) W, D, H
WEIGHT:	0.9kg (1.98lbs) approx.
ACCESSORIES:	Power supply, RC-IR3 infrared remote control transmitter
OPTIONS:	HDMI/HDMI male-to-male cables, RK-1 19" rack adapter

8 Default Communication Parameters

[Table 3](#) lists the default communication parameters for the **VM-114H**.

Table 3: Default Communication Parameters

RS-232	
Protocol 2000	
Baud Rate:	9600
Data Bits:	8
Stop Bits:	1
Parity:	None
Command Format:	HEX
Example (Output 1 to Input 1):	0x01, 0x81, 0x81, 0x81

¹ Specifications are subject to change without notice

9 Default EDID

The factory default EDID is listed below.

Monitor

Model name..... VM114H
 Manufacturer..... KRM
 Plug and Play D..... KRM0114
 Serial number..... 505-707455010
 Manufacture date..... 2009, ISO week 10

 EDID revision..... 1 3
 Input signal type..... Digital
 Color bit depth..... Undefined
 Display type..... RGB color
 Screen size..... 520 x 320 mm (24 0 in)
 Power management..... Standby, Suspend, Active off/sleep
 Extension blocs..... 1 (CEA-EXT)

 DDC/CI..... n/a

Color characteristics

Default color space..... Non-sRGB
 Display gamma..... 2.20
 Red chromaticity..... Rx 0.674 - Ry 0.319
 Green chromaticity..... Gx 0.188 - Gy 0.706
 Blue chromaticity..... Bx 0.148 - By 0.064
 White point (default).... Wx 0.313 - Wy 0.329
 Additional descriptors... None

Timing characteristics

Horizontal scan range.... 30-83kHz
 Vertical scan range..... 56-76Hz
 Video bandwidth..... 170MHz
 CVT standard..... Not supported
 GTF standard..... Not supported
 Additional descriptors... None
 Preferred timing..... Yes
 Native/preferred timing.. 1280x720p at 60Hz (16:10)
 Modeline..... "1280x720" 74.250 1280 1390 1430 1650 720 725 730 750 +hsync +vsync

Standard timings supported

720 x 400p at 70Hz - BM VGA
 640 x 480p at 60Hz - BM VGA
 640 x 480p at 75Hz - VESA
 800 x 600p at 60Hz - VESA
 800 x 600p at 75Hz - VESA
 1024 x 768p at 60Hz - VESA
 1024 x 768p at 75Hz - VESA
 1280 x 1024p at 75Hz - VESA
 1280 x 1024p at 60Hz - VESA STD
 1600 x 1200p at 60Hz - VESA STD
 1152 x 864p at 75Hz - VESA ST

10 Kramer Protocol 2000

This RS-232 communication protocol uses four bytes of information as defined below. The default data rate is 9600 baud, with no parity, 8 data bits and 1 stop bit.

Table 4: Protocol Definitions

	MSB							LSB
		DESTI- NATION	INSTRUCTION					
	0	D	N5	N4	N3	N2	N1	N0
	7	6	5	4	3	2	1	0
1st byte								
		INPUT						
	1	6	I5	I4	I3	I2	I1	I0
	7	6	5	4	3	2	1	0
2nd byte								
		OUTPUT						
	1	O6	O5	O4	O3	O2	O1	O0
	7	6	5	4	3	2	1	0
3rd byte								
			MACHINE NUMBER					
	1	OVR	X	M4	M3	M2	M1	M0
	7	6	5	4	3	2	1	0
4th byte								

1st BYTE: Bit 7 – Defined as 0

D – “DESTINATION”: 0 - for sending information to the switchers (from the PC);

1 - for sending to the PC (from the switcher)

N5 - N0 – “INSTRUCTION”

The function that is to be performed by the switcher(s) is defined by the INSTRUCTION (6 bits). Similarly, if a function is performed via the machine’s keyboard, then these bits are set with the INSTRUCTION NO., which was performed. The instruction codes are defined according to the table below (INSTRUCTION NO. is the value to be set for N5 - N0).

2nd BYTE: Bit 7 – Defined as 1

I6 - I0 – “INPUT”

When switching (ie instruction codes 1 and 2), the INPUT (7 bits) is set as the input number which is to be switched. Similarly, if switching is done via the machine’s front-panel, then these bits are set with the INPUT NUMBER which was switched. For other operations, these bits are defined according to the table.

3rd BYTE: Bit 7 – Defined as 1

O6 - O0 – “OUTPUT”

When switching (ie instruction codes 1 and 2), the OUTPUT (7 bits) is set as the output number which is to be switched. Similarly, if switching is done via the machine’s front-panel, then these bits are set with the OUTPUT NUMBER which was switched. For other operations, these bits are defined according to the table.

4th BYTE: Bit 7 – Defined as 1

Bit 5 – Don’t care

OVR – Machine number override

M4 - M0 – MACHINE NUMBER

Used to address machines in a system via their machine numbers. When several machines are controlled from a single serial port, they are usually configured together with each machine having an individual machine number. If the OVR bit is set, then all machine numbers will accept (implement) the command, and the addressed machine will reply.

For a single machine controlled via the serial port, always set M4 - M0 = 1, and make sure that the machine itself is configured as MACHINE NUMBER = 1.

Table 5: Instruction Codes for Protocol 2000

Note: All values in the table are decimal, unless otherwise stated

INSTRUCTION		DEFINITION FOR SPECIFIC INSTRUCTION		NOTE
#	DESCRIPTION	INPUT	OUTPUT	
1	SWITCH V DEO	Set equal to video input which is to be switched (0 = disconnect)	Set equal to video output which is to be switched (0 = to all the outputs)	2
61	IDENTIFY MACH NE	1 - video machine name 3 - video software version 9 - protocol 2000 version	0 - Request first 4 digits 1 - Request first suffix 2 - Request second suffix 3 - Request third suffix 10 - Request first prefix 11 - Request second prefix 12 - Request third prefix	13
62	DEFINE MACHINE	1 - number of inputs 2 - number of outputs	1 - for video 2 - for audio	14

NOTES on the above table:

NOTE 2 - These are bi-directional definitions That is, if the switcher receives the code, it will perform the instruction; and if the instruction is performed (due to a keystroke operation on the front panel), then these codes are sent For example, if the HEX code

01 85 88 83

was sent from the PC, then the switcher (machine 3) will switch input 5 to output 8 If the user switched input 1 to output 7 via the front panel keypad, then the switcher will send HEX codes:

41 81 87 83

to the PC

When the PC sends one of the commands in this group to the switcher, then, if the instruction is valid, the switcher replies by sending to the PC the same four bytes that it was sent (except for the first byte, where the DESTINATION bit is set high)

NOTE 13 - This is a request to identify the switcher/s in the system If the OUTPUT is set as 0, and the INPUT is set as 1, 2, 5 or 7, the machine will send its name The reply is the decimal value of the INPUT and OUTPUT For example, for a 2216, the reply to the request to send the audio machine name would be (HEX codes):

7D 96 90 81 (i e 128dec+ 22dec for 2nd byte, and 128dec+ 16dec for 3rd byte)

If the request for identification is sent with the INPUT set as 3 or 4, the appropriate machine will send its software version number Again, the reply would be the decimal value of the INPUT and OUTPUT - the INPUT representing the number in front of the decimal point, and the OUTPUT representing the number after it For example, for version 3 5, the reply to the request to send the version number would be (HEX codes):

7D 83 85 81 (i e 128dec+ 3dec for 2nd byte, 128dec+ 5dec for 3rd byte)

If the OUTPUT is set as 1, then the ASCII coding of the lettering following the machine's name is sent For example, for the VS-7588YC, the reply to the request to send the first suffix would be (HEX codes):

7D D9 C3 81 (i e 128dec+ ASCII for "Y"; 128dec+ ASCII for "C")

NOTE 14 - The number of inputs and outputs refers to the specific machine which is being addressed, not to the system For example, if six 16X16 matrices are configured to make a 48X32 system (48 inputs, 32 outputs), the reply to the HEX code

3E 82 81 82 (ie request the number of outputs)

would be HEX codes

7E 82 90 82

ie 16 outputs

LIMITED WARRANTY

The warranty obligations of Kramer Electronics for this product are limited to the terms set forth below:

What is Covered

This limited warranty covers defects in materials and workmanship in this product.

What is Not Covered

This limited warranty does not cover any damage, deterioration or malfunction resulting from any alteration, modification, improper or unreasonable use or maintenance, misuse, abuse, accident, neglect, exposure to excess moisture, fire, improper packing and shipping (such claims must be presented to the carrier), lightning, power surges, or other acts of nature. This limited warranty does not cover any damage, deterioration or malfunction resulting from the installation or removal of this product from any installation, any unauthorized tampering with this product, any repairs attempted by anyone unauthorized by Kramer Electronics to make such repairs, or any other cause which does not relate directly to a defect in materials and/or workmanship of this product. This limited warranty does not cover cartons, equipment enclosures, cables or accessories used in conjunction with this product.

Without limiting any other exclusion herein, Kramer Electronics does not warrant that the product covered hereby, including, without limitation, the technology and/or integrated circuit(s) included in the product, will not become obsolete or that such items are or will remain compatible with any other product or technology with which the product may be used.

How Long Does this Coverage Last

Seven years as of this printing, please check our Web site for the most current and accurate warranty information.

Who is Covered

Only the original purchaser of this product is covered under this limited warranty. This limited warranty is not transferable to subsequent purchasers or owners of this product.

What Kramer Electronics will do

Kramer Electronics will, at its sole option, provide one of the following three remedies to whatever extent it shall deem necessary to satisfy a proper claim under this limited warranty:

1. Elect to repair or facilitate the repair of any defective parts within a reasonable period of time, free of any charge for the necessary parts and labor to complete the repair and restore this product to its proper operating condition. Kramer Electronics will also pay the shipping costs necessary to return this product once the repair is complete.
2. Replace this product with a direct replacement or with a similar product deemed by Kramer Electronics to perform substantially the same function as the original product.
3. Issue a refund of the original purchase price less depreciation to be determined based on the age of the product at the time remedy is sought under this limited warranty.

What Kramer Electronics will not do Under This Limited Warranty

If this product is returned to Kramer Electronics or the authorized dealer from which it was purchased or any other party authorized to repair Kramer Electronics products, this product must be insured during shipment, with the insurance and shipping charges prepaid by you. If this product is returned uninsured, you assume all risks of loss or damage during shipment. Kramer Electronics will not be responsible for any costs related to the removal or re-installation of this product from or into any installation. Kramer Electronics will not be responsible for any costs related to any setting up this product, any adjustment of user controls or any programming required for a specific installation of this product.

How to Obtain a Remedy under this Limited Warranty

To obtain a remedy under this limited warranty, you must contact either the authorized Kramer Electronics reseller from whom you purchased this product or the Kramer Electronics office nearest you. For a list of authorized Kramer Electronics resellers and/or Kramer Electronics authorized service providers, please visit our web site at www.kramerelectronics.com or contact the Kramer Electronics office nearest you.

In order to pursue any remedy under this limited warranty, you must possess an original, dated receipt as proof of purchase from an authorized Kramer Electronics reseller. If this product is returned under this limited warranty, a return authorization number, obtained from Kramer Electronics, will be required. You may also be directed to an authorized reseller or a person authorized by Kramer Electronics to repair the product.

If it is decided that this product should be returned directly to Kramer Electronics, this product should be properly packed, preferably in the original carton, for shipping. Cartons not bearing a return authorization number will be refused.

Limitation on Liability

THE MAXIMUM LIABILITY OF KRAMER ELECTRONICS UNDER THIS LIMITED WARRANTY SHALL NOT EXCEED THE ACTUAL PURCHASE PRICE PAID FOR THE PRODUCT. TO THE MAXIMUM EXTENT PERMITTED BY LAW, KRAMER ELECTRONICS IS NOT RESPONSIBLE FOR DIRECT, SPECIAL, INCIDENTAL OR CONSEQUENTIAL DAMAGES RESULTING FROM ANY BREACH OF WARRANTY OR CONDITION, OR UNDER ANY OTHER LEGAL THEORY. Some countries, districts or states do not allow the exclusion or limitation of relief, special, incidental, consequential or indirect damages, or the limitation of liability to specified amounts, so the above limitations or exclusions may not apply to you.

Exclusive Remedy

TO THE MAXIMUM EXTENT PERMITTED BY LAW, THIS LIMITED WARRANTY AND THE REMEDIES SET FORTH ABOVE ARE EXCLUSIVE AND IN LIEU OF ALL OTHER WARRANTIES, REMEDIES AND CONDITIONS, WHETHER ORAL OR WRITTEN, EXPRESS OR IMPLIED. TO THE MAXIMUM EXTENT PERMITTED BY LAW, KRAMER ELECTRONICS SPECIFICALLY DISCLAIMS ANY AND ALL IMPLIED WARRANTIES, INCLUDING, WITHOUT LIMITATION, WARRANTIES OF MERCHANTABILITY AND FITNESS FOR A PARTICULAR PURPOSE. IF KRAMER ELECTRONICS CANNOT LAWFULLY DISCLAIM OR EXCLUDE IMPLIED WARRANTIES UNDER APPLICABLE LAW, THEN ALL IMPLIED WARRANTIES COVERING THIS PRODUCT, INCLUDING WARRANTIES OF MERCHANTABILITY AND FITNESS FOR A PARTICULAR PURPOSE, SHALL APPLY TO THIS PRODUCT AS PROVIDED UNDER APPLICABLE LAW.

IF ANY PRODUCT TO WHICH THIS LIMITED WARRANTY APPLIES IS A "CONSUMER PRODUCT" UNDER THE MAGNUSON-MOSS WARRANTY ACT (15 U.S.C. §2301, ET SEQ.) OR OTHER APPLICABLE LAW, THE FOREGOING DISCLAIMER OF IMPLIED WARRANTIES SHALL NOT APPLY TO YOU, AND ALL IMPLIED WARRANTIES ON THIS PRODUCT, INCLUDING WARRANTIES OF MERCHANTABILITY AND FITNESS FOR THE PARTICULAR PURPOSE, SHALL APPLY AS PROVIDED UNDER APPLICABLE LAW.

Other Conditions

This limited warranty gives you specific legal rights, and you may have other rights which vary from country to country or state to state.

This limited warranty is void if (i) the label bearing the serial number of this product has been removed or defaced, (ii) the product is not distributed by Kramer Electronics or (iii) this product is not purchased from an authorized Kramer Electronics reseller. If you are unsure whether a reseller is an authorized Kramer Electronics reseller, please visit our Web site at www.kramerelectronics.com or contact a Kramer Electronics office from the list at the end of this document.

Your rights under this limited warranty are not diminished if you do not complete and return the product registration form or complete and submit the online product registration form. Kramer Electronics thanks you for purchasing a Kramer Electronics product. We hope it will give you years of satisfaction.



For the latest information on our products and a list of Kramer distributors, visit www.kramerelectronics.com where updates to this user manual may be found. We welcome your questions, comments and feedback.



Caution

Safety Warning:

Disconnect the unit from the power supply before opening/servicing.



P/N: 2900-000643



Rev: 8

