

**Kramer Electronics, Ltd.**



# **USER MANUAL**

**Model:**

**6602**

*4x1 AES/EBU Switcher / DA*

## Contents

<b>1</b>	<b>Introduction</b>	<b>1</b>
<b>2</b>	<b>Getting Started</b>	<b>1</b>
<b>3</b>	<b>Your AES/EBU Switcher / DA</b>	<b>1</b>
<b>4</b>	<b>Connecting the AES/EBU Switcher / DA</b>	<b>3</b>
<b>5</b>	<b>Technical Specifications</b>	<b>4</b>

## Figures

Figure 1:	6602 4x1 AES/EBU Switcher / DA	2
Figure 2:	Connecting the 6602 4x1 AES/EBU Switcher / DA	3

## Tables

Table 1:	Features and Functions of the 6602 4x1 AES/EBU Switcher / DA	2
Table 2:	Technical Specifications of the 6602 4x1 AES/EBU Switcher / DA	4

## 1 Introduction

Dedication by Kramer Electronics since 1981, to the development and manufacture of high quality video/audio equipment, makes the Kramer line an integral part of the finest production and presentation facilities in the world. In recent years, Kramer has redesigned and upgraded most of the line, making the best even better! The Kramer line of professional video/audio electronics is one of the most versatile and complete available, and is a true leader in terms of quality, workmanship, price/performance ratio and innovation. In addition to our high quality Kramer DigiTOOLS, distribution amplifiers, and switchers and matrices, we also offer excellent remote controllers, processors, interfaces and computer-related products.

Congratulations on purchasing your Kramer **6602 4x1 AES/EBU Switcher / DA**. This product is ideal for the following typical applications:

- Video broadcast studios for On-Air switching and signal routing
- Non-linear editing suites
- Video production studios, to connect various sources to acceptors

The package includes the following items:

- **6602 4x1 AES/EBU Switcher / DA**
- Power adapter (12V DC Input)
- This user manual
- Kramer concise product catalog/CD

## 2 Getting Started

We recommend that you:

- Unpack the equipment carefully and save the original box and packaging materials for possible future shipment
- Review the contents of this user manual

## 3 Your AES/EBU Switcher / DA

The **6602 4x1 AES/EBU Switcher / DA** outputs the selected digital audio input to 2 digital audio outputs (doubling as a 1:2 DA). In addition, the **6602 4x1 AES/EBU Switcher / DA**:

- Is adjustment-free
- Provides automatic equalization for losses on 110 $\Omega$  twisted pair cable
- Reclocks the input signal to provide 2 low-jitter digital outputs

- Supports multi-standards - AES/EBU, IEC 958, S/PDIF and EIAJ CP340/1201 professional and consumer formats with sampling frequencies up to 96 kHz
- Does not alter any system information in the audio serial stream
- Includes transformer coupled inputs and outputs - supporting 110Ω twisted pair cable on detachable terminal block connectors

Achieving the best performance means:

- Connecting only good quality connection cables, thus avoiding interference, deterioration in signal quality due to poor matching, and elevated noise levels (often associated with low quality cables)
- Avoiding interference from neighboring electrical appliances that may adversely influence signal quality
- Positioning your Kramer **6602 4x1 AES/EBU Switcher / DA** in a location free from moisture and away from excessive sunlight and dust

Figure 1 and Table 1 define the **6602 4x1 AES/EBU Switcher / DA**:

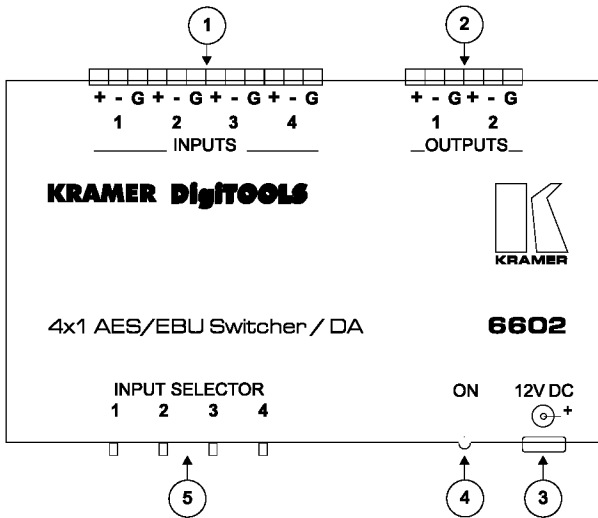

Figure 1: 6602 4x1 AES/EBU Switcher / DA

Table 1: Features and Functions of the 6602 4x1 AES/EBU Switcher / DA

#	Feature	Function
1	INPUTS	Digital audio input (110Ω) (1 to 4) on detachable terminal blocks
2	OUTPUTS	Digital audio outputs (110Ω) (1 to 2) on detachable terminal blocks
3	12V DC	+12V DC connector for powering the unit
4	ON LED	Illuminates when receiving power
5	INPUT SELECTOR Switches	Select the digital audio sources (from 1 to 4)

## 4 Connecting the AES/EBU Switcher / DA

To connect your **6602 4x1 AES/EBU Switcher / DA**, as Figure 2 illustrates:

1. Connect a shielded twisted pair cable from the detachable terminal block INPUT connector to the digital audio source (for example, a DAT-Player).  
*Note: Connect up to<sup>1</sup> 4 DAT-Players.*
2. Connect a shielded twisted pair cable from the detachable terminal block OUTPUT connector to the digital audio acceptor (for example, a DAT-Recorder).  
*Note: Connect up to<sup>2</sup> 2 DAT-Recorders.*
3. Connect the 12V DC power adapter to the power socket and connect the adapter to the mains electricity.

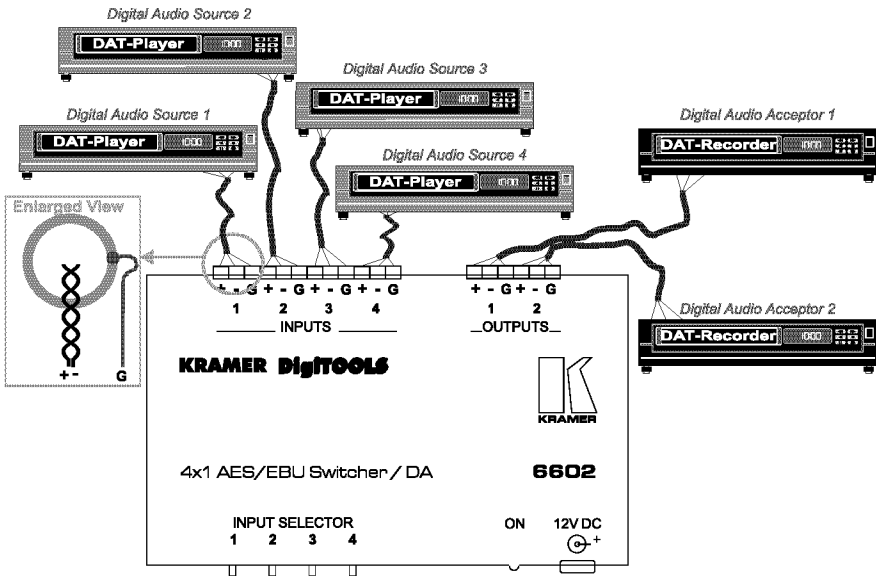

Figure 2: Connecting the 6602 4x1 AES/EBU Switcher / DA

1 You do not have to connect all the inputs

2 You do not have to connect all the outputs

## 5 Technical Specifications

*Table 2: Technical Specifications of the 6602 4x1 AES/EBU Switcher / DA*

Inputs:	4 digital audio transformer coupled inputs (110Ω) on detachable terminal blocks
Outputs:	2 digital audio transformer coupled outputs (110Ω) on detachable terminal blocks
Sampling:	32, 44.1, 48, 96 kHz sampling frequencies
Standards:	AES/EBU, IEC 958, S/PDIF and EIAJ CP340/1201
Equalization:	Automatic equalization for losses on 110Ω twisted pair cable
Dimensions:	12 cm x 7.5 cm x 2.5 cm (4.7" x 2.95" x 0.98", W, D, H)
Power Source:	12 VDC, 60 mA
Weight:	0.25 kg (0.6 lbs.) approx.
Accessories:	Power supply, mounting bracket
Options:	RK-T1 or RK-T3 rack mount kit

---

## LIMITED WARRANTY

Kramer Electronics (hereafter *Kramer*) warrants this product free from defects in material and workmanship under the following terms.

### HOW LONG IS THE WARRANTY

Labor and parts are warranted for three years from the date of the first customer purchase.

### WHO IS PROTECTED?

Only the first purchase customer may enforce this warranty.

### WHAT IS COVERED AND WHAT IS NOT COVERED

Except as below, this warranty covers all defects in material or workmanship in this product. The following are not covered by the warranty:

1. Any product which is not distributed by Kramer, or which is not purchased from an authorized Kramer dealer. If you are uncertain as to whether a dealer is authorized, please contact Kramer at one of the agents listed in the web site [www.kramerelectronics.com](http://www.kramerelectronics.com).
2. Any product, on which the serial number has been defaced, modified or removed.
3. Damage, deterioration or malfunction resulting from:
  - i) Accident, misuse, abuse, neglect, fire, water, lightning or other acts of nature
  - ii) Product modification, or failure to follow instructions supplied with the product
  - iii) Repair or attempted repair by anyone not authorized by Kramer
  - iv) Any shipment of the product (claims must be presented to the carrier)
  - v) Removal or installation of the product
  - vi) Any other cause, which does not relate to a product defect
  - vii) Cartons, equipment enclosures, cables or accessories used in conjunction with the product

### WHAT WE WILL PAY FOR AND WHAT WE WILL NOT PAY FOR

We will pay labor and material expenses for covered items. We will not pay for the following:

1. Removal or installations charges.
2. Costs of initial technical adjustments (set-up), including adjustment of user controls or programming. These costs are the responsibility of the Kramer dealer from whom the product was purchased.
3. Shipping charges.

### HOW YOU CAN GET WARRANTY SERVICE

1. To obtain service on your product, you must take or ship it prepaid to any authorized Kramer service center.
2. Whenever warranty service is required, the original dated invoice (or a copy) must be presented as proof of warranty coverage, and should be included in any shipment of the product. Please also include in any mailing a contact name, company, address, and a description of the problem(s).
3. For the name of the nearest Kramer authorized service center, consult your authorized dealer.

### LIMITATION OF IMPLIED WARRANTIES

All implied warranties, including warranties of merchantability and fitness for a particular purpose, are limited in duration to the length of this warranty.

### EXCLUSION OF DAMAGES

The liability of Kramer for any effective products is limited to the repair or replacement of the product at our option. Kramer shall not be liable for:

1. Damage to other property caused by defects in this product, damages based upon inconvenience, loss of use of the product, loss of time, commercial loss; or:
2. Any other damages, whether incidental, consequential or otherwise. Some countries may not allow limitations on how long an implied warranty lasts and/or do not allow the exclusion or limitation of incidental or consequential damages, so the above limitations and exclusions may not apply to you.

This warranty gives you specific legal rights, and you may also have other rights, which vary from place to place.

**NOTE:** All products returned to Kramer for service must have prior approval. This may be obtained from your dealer.

This equipment has been tested to determine compliance with the requirements of:

- EN-50081: "Electromagnetic compatibility (EMC);  
generic emission standard.  
Part 1: Residential, commercial and light industry"
- EN-50082: "Electromagnetic compatibility (EMC) generic immunity standard.  
Part 1: Residential, commercial and light industry environment".
- CFR-47: FCC Rules and Regulations:  
Part 15: "Radio frequency devices  
Subpart B – Unintentional radiators"

### CAUTION!

- ☒ Servicing the machines can only be done by an authorized Kramer technician. Any user who makes changes or modifications to the unit without the expressed approval of the manufacturer will void user authority to operate the equipment.
- ☒ Use the supplied DC power supply to feed power to the machine.
- ☒ Please use recommended interconnection cables to connect the machine to other components.



**The list of Kramer distributors appears on our web site:  
[www.kramerelectronics.com](http://www.kramerelectronics.com)**

**We welcome your questions, comments and feedback.**

---

**Kramer Electronics, Ltd.**

3 Am VeOlamo Street, Jerusalem 95463, Israel Tel: (+972-2)-654-4000

Fax: (+972-2)-653-5369, E-mail: [kramere1@netvision.net.il](mailto:kramere1@netvision.net.il)

**P/N: 2900-002023 REV 1**