

Kramer Electronics, Ltd.



USER MANUAL

Model:

VS-21HDCP

2x1 DVI Switcher

Contents

1	Introduction	1
2	Getting Started	1
2.1	Quick Start	2
3	Overview	3
3.1	About HDCP	3
3.2	Recommendations for Best Performance	3
4	Your VS-21HDCP 2x1 DVI Switcher	4
5	Connecting a VS-21HDCP 2x1 DVI Switcher	5
6	Technical Specifications	7

Figures

Figure 1:	VS-21HDCP 2x1 DVI Switcher	4
Figure 2:	VS-21HDCP (Top Side Panel)	4
Figure 3:	VS-21HDCP (Lower Side Panel)	4
Figure 4:	Connecting a VS-21HDCP 2x1 DVI Switcher	6

Tables

Table 1:	VS-21HDCP 2x1 DVI Switcher Features	5
Table 2:	Technical Specifications of the VS-21HDCP 2x1 DVI Switcher	7

1 Introduction

Welcome to Kramer Electronics (since 1981): a world of unique, creative and affordable solutions to the infinite range of problems that confront the video, audio and presentation professional on a daily basis. In recent years, we have redesigned and upgraded most of our line, making the best even better! Our 500-plus different models now appear in 8 Groups¹, which are clearly defined by function.

Congratulations on purchasing your Kramer **DigiTOOLS® VS-21HDCP 2x1 DVI Switcher**.

The **VS-21HDCP** is ideal for:

- Presentation graphics selection and routing

Each package includes the following items:

- **VS-21HDCP 2x1 DVI Switcher**
- Power adapter (12V DC Input)
- This user manual²

2 Getting Started

We recommend that you:

- Unpack the equipment carefully and save the original box and packaging materials for possible future shipment
- Review the contents of this user manual
- Use Kramer high performance high resolution cables³

1 GROUP 1: Distribution Amplifiers; GROUP 2: Video and Audio Switchers, Matrix Switchers and Controllers; GROUP 3: Video, Audio, VGA/XGA Processors; GROUP 4: Interfaces and Sync Processors; GROUP 5: Twisted Pair Interfaces; GROUP 6: Accessories and Rack Adapters; GROUP 7: Scan Converters and Scalers; and GROUP 8: Cables and Connectors

2 Download up-to-date Kramer user manuals from our Web site at <http://www.kramerelectronics.com>

3 The complete list of Kramer cables is on our Web site at <http://www.kramerelectronics.com>

2.1 Quick Start

This quick start chart summarizes the basic setup and operation steps.

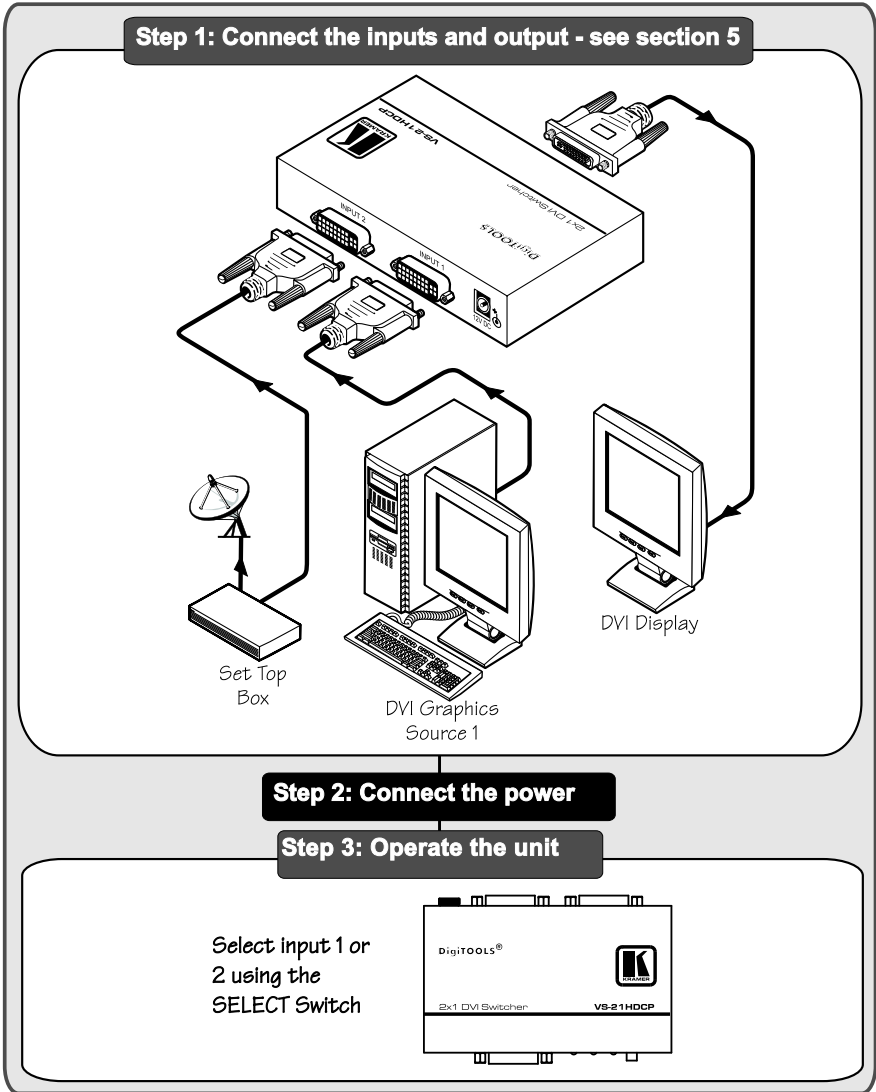

3 Overview

The high quality Kramer **VS-21HDCP** is an HDCP (High-Bandwidth Digital Content Protection)¹ compatible *2x1 DVI Switcher* that accepts two DVI inputs—letting you select either DVI² input using a switch located on the front panel—and routes the selected DVI input signal to the DVI output.

3.1 About HDCP

The High-Bandwidth Digital Content Protection (HDCP) standard (developed by Intel), protects digital video and audio signals transmitted over DVI or HDMI connections between two HDCP-enabled devices to eliminate the reproduction of copyrighted material. To protect copyright holders (such as movie studios) from having their programs copied and shared, the HDCP standard provides for the secure and encrypted transmission of digital signals.

3.2 Recommendations for Best Performance

Achieving the best performance means:

- Connecting only good quality connection cables, thus avoiding interference, deterioration in signal quality due to poor matching, and elevated noise levels (often associated with low quality cables)
- Avoiding interference from neighboring electrical appliances and positioning your **VS-21HDCP** away from moisture, excessive sunlight and dust



Caution – No operator-serviceable parts inside unit.

Warning – Use only the Kramer Electronics input power wall adapter that is provided with this unit³.

Warning – Disconnect power and unplug unit from wall before installing or removing device or servicing unit.

¹ Note that Kramer Electronics Limited is an HDCP Licensee, see <http://www.digital-cp.com/list/>

² DVI-D (Digital) Note that only the digital signal (DVI-D) is available on the DVI connector

³ For example: model number AD2512C, part number 2535-000251

4 Your VS-21HDCP 2x1 DVI Switcher

Figure 1, Figure 2, Figure 3 and Table 1 define the **VS-21HDCP**:

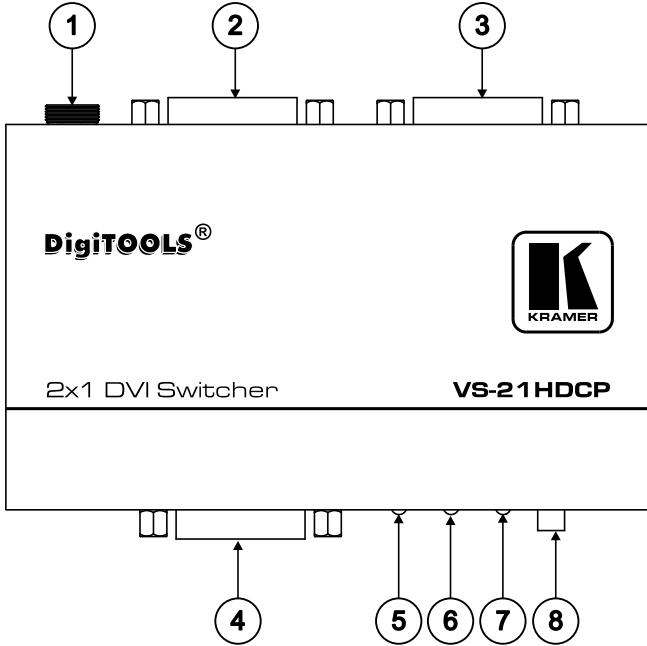

Figure 1: VS-21HDCP 2x1 DVI Switcher

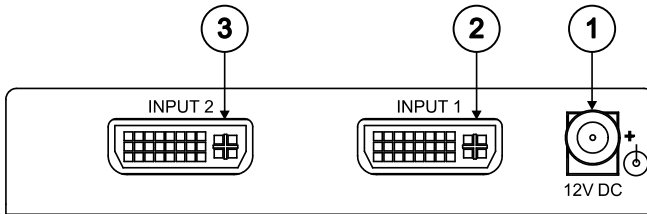

Figure 2: VS-21HDCP (Top Side Panel)

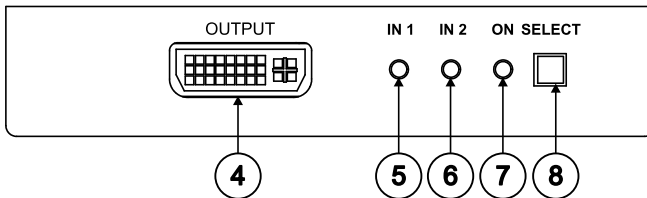

Figure 3: VS-21HDCP (Lower Side Panel)

Table 1: VS-21HDCP 2x1 DVI Switcher Features

#	Feature	Function
1	12V DC	+12V DC connector for powering the unit
2	INPUT 1 DVI Connector	Connect to the DVI source 1
3	INPUT 2 DVI Connector	Connect to the DVI source 2
4	OUTPUT DVI Connector	Connect to the DVI acceptor
5	IN 1 LED	Lights when input 1 is selected
6	IN 2 LED	Lights when input 2 is selected
7	ON LED	Lights when receiving power
8	SELECT Switch	Press to toggle between selecting input 1 and input 2

5 Connecting a VS-21HDCP 2x1 DVI Switcher

To connect the **VS-21HDCP 2x1 DVI Switcher**, as illustrated in the example in Figure 4, do the following¹:

1. Connect up to 2 DVI sources to the INPUT connectors, as follows:
 - INPUT 1 connector to DVI source 1 (for example, a computer)
 - INPUT 2 connector to DVI source 2 (for example, a set top box)
2. Connect the OUTPUT connector to the DVI acceptor (for example, a display).
3. Connect the 12V DC power adapter (wall transformer) to the 12V DC socket and connect the transformer to the mains electricity.

¹ Switch OFF the power on each device before connecting it to your VS-21HDCP. After connecting your VS-21HDCP, switch on its power and then switch on the power on each device

Connecting a VS-21HDCP 2x1 DVI Switcher

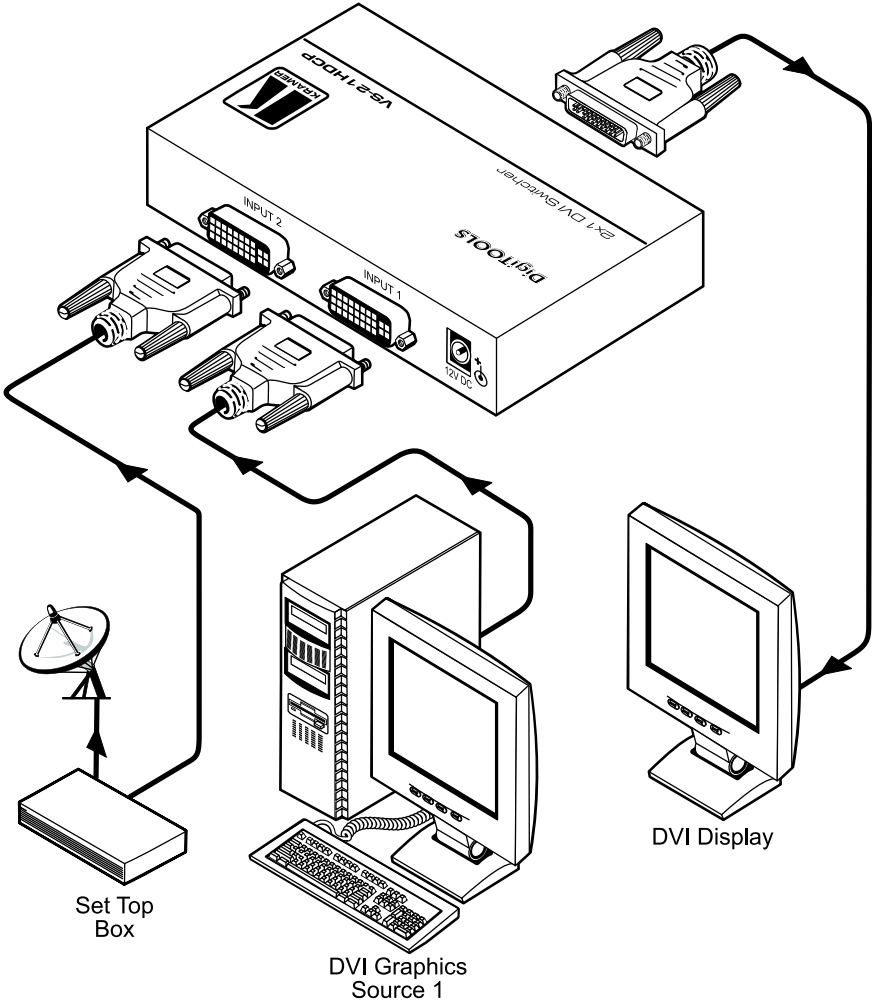

Figure 4: Connecting a VS-21HDCP 2x1 DVI Switcher

6 Technical Specifications

Table 2 includes the technical specifications:

Table 2: Technical Specifications¹ of the VS-21HDCEP 2x1 DVI Switcher

INPUTS:	2 DVI ² , 1 2Vpp on a DVI Molex 24pin female connector; DDC signal 5Vpp (TTL)
OUTPUT:	1 DVI ² , 1.2Vpp on DVI Molex 24pin female connectors; DDC signal 5Vpp (TTL)
BANDWIDTH:	1.65Gbps per graphic channel
POWER SOURCE:	12V DC, 390mA
DIMENSIONS:	12 cm x 7.5 cm x 2.5 cm (4.7" x 2.95" 0.98", W, D, H)
WEIGHT:	0.3 kg (0.67 lbs.) approx
ACCESSORIES:	Power Adapter
OPTIONS:	Kramer DVI cables ³

1 Specifications are subject to change without notice

2 On a DVI-I connector Note that only the digital signal (DVI-D) is available on the DVI connector

3 The complete list of Kramer cables is on our Web site at <http://www.kramerelectronics.com>

LIMITED WARRANTY

Kramer Electronics (hereafter *Kramer*) warrants this product free from defects in material and workmanship under the following terms

HOW LONG IS THE WARRANTY

Labor and parts are warranted for seven years from the date of the first customer purchase

WHO IS PROTECTED?

Only the first purchase customer may enforce this warranty

WHAT IS COVERED AND WHAT IS NOT COVERED

Except as below, this warranty covers all defects in material or workmanship in this product. The following are not covered by the warranty:

- 1 Any product which is not distributed by Kramer, or which is not purchased from an authorized Kramer dealer. If you are uncertain as to whether a dealer is authorized, please contact Kramer at one of the agents listed in the Web site www.kramerelectronics.com
- 2 Any product, on which the serial number has been defaced, modified or removed
- 3 Damage, deterioration or malfunction resulting from:
 - i) Accident, misuse, abuse, neglect, fire, water, lightning or other acts of nature
 - ii) Product modification, or failure to follow instructions supplied with the product
 - iii) Repair or attempted repair by anyone not authorized by Kramer
 - iv) Any shipment of the product (claims must be presented to the carrier)
 - v) Removal or installation of the product
 - vi) Any other cause, which does not relate to a product defect
 - vii) Cartons, equipment enclosures, cables or accessories used in conjunction with the product

WHAT WE WILL PAY FOR AND WHAT WE WILL NOT PAY FOR

We will pay labor and material expenses for covered items. We will not pay for the following:

- 1 Removal or installations charges
- 2 Costs of initial technical adjustments (set-up), including adjustment of user controls or programming. These costs are the responsibility of the Kramer dealer from whom the product was purchased
- 3 Shipping charges

HOW YOU CAN GET WARRANTY SERVICE

- 1 To obtain service on you product, you must take or ship it prepaid to any authorized Kramer service center
- 2 Whenever warranty service is required, the original dated invoice (or a copy) must be presented as proof of warranty coverage, and should be included in any shipment of the product. Please also include in any mailing a contact name, company, address, and a description of the problem(s)
- 3 For the name of the nearest Kramer authorized service center, consult your authorized dealer

LIMITATION OF IMPLIED WARRANTIES

All implied warranties, including warranties of merchantability and fitness for a particular purpose, are limited in duration to the length of this warranty

EXCLUSION OF DAMAGES

The liability of Kramer for any effective products is limited to the repair or replacement of the product at our option. Kramer shall not be liable for:

- 1 Damage to other property caused by defects in this product, damages based upon inconvenience, loss of use of the product, loss of time, commercial loss; or:
- 2 Any other damages, whether incidental, consequential or otherwise. Some countries may not allow limitations on how long an implied warranty lasts and/or do not allow the exclusion or limitation of incidental or consequential damages, so the above limitations and exclusions may not apply to you

This warranty gives you specific legal rights, and you may also have other rights, which vary from place to place

NOTE: All products returned to Kramer for service must have prior approval. This may be obtained from your dealer.

This equipment has been tested to determine compliance with the requirements of:

- EN-50081: "Electromagnetic compatibility (EMC);
generic emission standard
Part 1: Residential, commercial and light industry"
- EN-50082: "Electromagnetic compatibility (EMC) generic immunity standard
Part 1: Residential, commercial and light industry environment"
- CFR-47: FCC Rules and Regulations:
Part 15: "Radio frequency devices
Subpart B Unintentional radiators"

CAUTION!

- Servicing the machines can only be done by an authorized Kramer technician. Any user who makes changes or modifications to the unit without the expressed approval of the manufacturer will void user authority to operate the equipment.
- Use the supplied DC power supply to feed power to the machine.
- Please use recommended interconnection cables to connect the machine to other components.



For the latest information on our products and a list of Kramer distributors, visit our Web site: www.kramerelectronics.com, where updates to this user manual may be found. We welcome your questions, comments and feedback.



Caution

Safety Warning:

Disconnect the unit from the power supply before opening/servicing.



Kramer Electronics, Ltd.

Web site: www.kramerelectronics.com

E-mail: info@kramerel.com

P/N: 2900-000291 REV 1