



KRAMER ELECTRONICS Ltd.

USER MANUAL

SDI and Digital Audio Distribution Amplifiers

Models:

6104

SD-7108

SD-7208

SD-7816

SD-7816B

**IMPORTANT: Before proceeding, please read paragraph entitled
"Unpacking and Contents"**



Table Of Contents

Section	Name	Page
1	INTRODUCTION	2
1.1	Digital and Analog Signals	2
1.2	Several Points to Consider when Working with Digital Signals	2
1.3	SDI Standards	4
1.4	Factors Affecting Quality of Results	4
2	SPECIFICATIONS	5
3	HOW DO I GET STARTED?	6
4	UNPACKING AND CONTENTS	6
5	OPTIONAL ACCESSORIES	6
6	SDI AND DIGITAL AUDIO DISTRIBUTORS	7
6.1	Getting to Know Your 6104 Distributor	7
6.2	Getting to Know Your SD-7108 Distributor / Deserializer	8
6.3	Getting to Know Your SD-7208 Serializer / Distributor	9
6.4	Getting to Know Your SD-7816 Digital Audio Distributor	10
6.5	Getting to Know Your SD-7816B Digital Audio Distributor	11
7	INSTALLATION	12
8	CONNECTING TO DIGITAL VIDEO DEVICES	12
9	CONNECTING TO DIGITAL AUDIO DEVICES	12
10	TURNING ON THE MACHINES	12
10.1	Operation of the SDI Distributors	13
10.2	Operation of the Digital Audio Distributors	13
10.2.1	Programming	15
10.2.2	Indication	15
11	TAKING CARE OF YOUR MACHINE	15
12	TROUBLESHOOTING	16
12.1	Power and Indicators	16
12.2	SDI and Digital Audio Signals	16
	Limited Warranty	17

List Of Illustrations

Figure		Page
1	Digital “eye” Diagram	3
2	The Digital “eye” after accumulating noise and jitter	4
3	6104 Front/Rear Panel Features	7
4	SD-7108 Front/Rear panel Features	8
5	SD-7208 Front/Rear panel Features	9
6	SD-7816 Front/Rear panel Features	10
7	SD-7816B Front/Rear panel Features	11
8	Signal peak-to-peak measurement	13
9	Compensation level	14

List Of Tables

Table		Page
1	6104 Front/Rear Panel Features	7
2	SD-7108 Front/Rear panel Features	8
3	SD-7208 Front/Rear panel Features	9
4	SD-7816 Front/Rear panel Features	10
5	SD-7816B Front/Rear panel Features	11
6	Dip-Switch settings for signal level compensation	15

1 INTRODUCTION

Congratulations on your purchase of this Kramer Electronics SDI / Digital Audio Distributor. Since 1981, Kramer has been dedicated to the development and manufacture of high quality video/audio equipment. The Kramer line has become an integral part of many of the best production and presentation facilities around the world. In recent years, Kramer has redesigned and upgraded most of the line, making the best even better. Kramer's line of professional video/audio electronics is one of the most versatile and complete available, and is a true leader in terms of quality, workmanship, price/performance ratio and innovation. In addition to the Kramer line of high quality distributors, such as the one you have just purchased, Kramer also offers a full line of high quality switchers, processors, interfaces, controllers and computer-related products.

This manual includes configuration, operation and option information for the following products from the Kramer line of SDI and Digital Audio Distributors.

6104 – 1:4 SDI Distributor (Kramer DigiTOOLS)

SD-7108 – 1:8 SDI Distributor / Deserializer

SD-7208 – Serializer / 1:8 SDI Distributor

SD-7816 – 2x1:8 or 1:16 Digital Balanced Audio Distributor

SD-7816B – 2x1:8 or 1:16 Digital Unbalanced Audio Distributor

1.1 Digital and Analog signals

An analog signal varies continuously. It may have any value (within its physical bounds) and can change at any instant. A digital signal is made up of a finite number of discrete levels, usually – but not always – changing only at discrete time periods. An example of a digitized waveform is shown below.

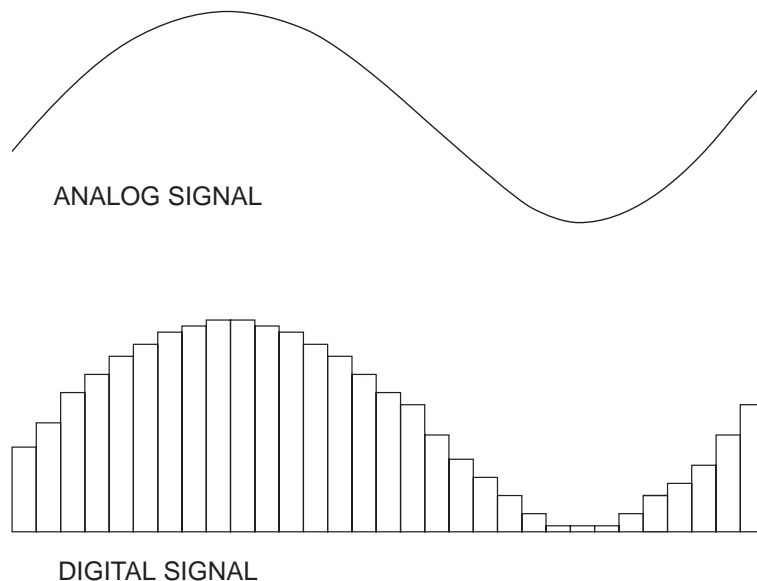

1.2 Several points to consider when working with digital signals

The minimum noise introduced by quantizing is 1 bit (1 level), so the higher the number of bits, the lower the inherent noise, and the higher the resolution.

Since A/D and D/A conversions create artifacts, it is important not to convert back and forth. In a “mixed” outfit, the video should be digitized, and *all* the digital processing done before converting back to analog.

“Multi-media” systems usually quantize the video to 8 bits (i.e. $2^8 = 256$) levels. Some “levels” are dedicated to special codes (SAV, EAV – similar to syncs in analog video), leaving 220 quantization levels (~3mV steps) for the luminance signals. Audio is usually quantized to 16 bits for multi-media systems.

Broadcast systems usually use 10-bit video, and 20- to 24- bit audio.

The advantages of working in a digital domain are obvious – a digital signal may be transported very easily, and saved and retrieved reliably with no generation losses.

The transmission of a digital video signal is reliable up to a certain length of cable. Beyond this length, the signal is destroyed. This phenomenon is known as the “cliff-effect”. To avoid the “crash” at the cliff, an “equalizer and reclocker” should be inserted at a distance less than the “cliff” length. From this point it is again possible to drive a cable up to the “cliff” length. This is similar to the “repeater” analogy for analog signals. (Note: the term “equalizer” is usually dropped, and the “equalizer and reclocker” is often referred to simply as a “reclocker”).

“Equalization” is a process of amplifying the input signal to overcome losses on the cable. For digital signals, this is possible, since the correct amplitude of the signal is known!

“Reclocking” is a process of “cleaning up” the signal in the time-domain, i.e., removing the jitter which was introduced as a result of the long cable. To do this, the timing source must be recovered from the signal, and the signal is regenerated with stable timing.

A graphic representation of the timing and amplitude distortions is shown in an “eye diagram”, as below:

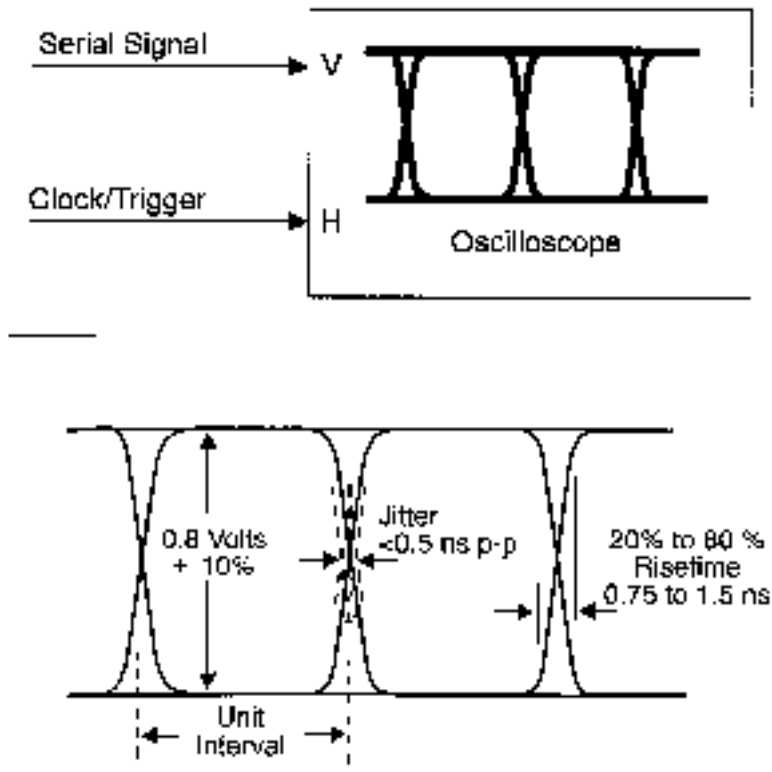

Figure 1: Digital “eye” Diagram

Increase in jitter and decrease in amplitude cause the eye to “close”. It is clear that jitter of more than $\pm 50\%$ would result in an irretrievable signal (cliff effect).

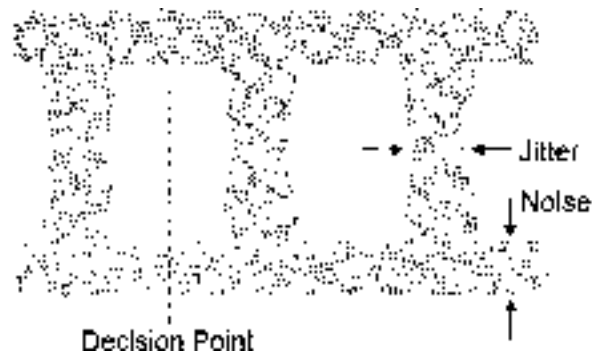

Figure 2: The Digital “eye” after accumulating noise and jitter

1.3 SDI Standards

Today, “uncompressed” digital video usually refers to digital component video (the ITU-R BT.601 standard). This is based on a sampling of component video. The sampling scheme stipulates one luminance (Y) sample for each pair of color-difference (R-Y and B-Y) samples.

Luminance sampling is done at 13.5MS/s (mega-samples per second), and each color-difference is sampled at 6.75MS/s. This is also known as 4:2:2 (Y is sampled at $4f_{sc}$ (more or less!), and the color differences at $2f_{sc}$).

The 8 or 10 bits of data are serialized to produce a single stream of bits (SMPTE-259 standard) at 270MS/s for 10 bits ($10 \times (13.5 + 6.75 + 6.75) = 270$). This is known as “Serial Component Video”, and is usually referred to as SDI.

“Serial Composite Video” is (true) $4f_{sc}$ sampling of composite video – PAL at ~ 177 MS/s, and NTSC at ~ 143 MS/s. This standard is hardly used, except in some older installations in the USA.

The “Digital Widescreen” standard was launched in the early 90’s. This is a digital version of Pal Plus (16:9 or Letterbox aspect ratio), and it works at 360MS/s.

1.4 Factors Affecting Quality of Results

There are many factors affecting the quality of signals transmitted from a source to an acceptor. The following examples illustrate the effect on analog video and audio. For digital signals, the interference would effectively decrease “cliff” length.

Connection cables

Low quality cables are susceptible to interference; they degrade signal quality due to poor matching and cause elevated noise levels. They should therefore be of the best quality.

Sockets and connectors of the sources and acceptors

So often ignored, they should be of highest quality, since "Zero ohm" connection resistance is the objective. Sockets and connectors also must match the required impedance (75ohm in video). Cheap, low quality connectors tend to rust, thus causing breaks in the signal path.

Amplifying circuitry

Must have quality performance when the desired result is high linearity, low distortion and low noise operation.

Distance between sources and acceptors

Plays a major role in the final result. For long distances (over 15 meters) between sources and acceptors, special measures should be taken in order to avoid cable losses. These include using higher quality cables or adding line amplifiers.

Interference from neighboring electrical appliances

These can have an adverse effect on signal quality. Balanced audio lines are less prone to interference, but unbalanced audio should be installed far from any mains power cables, electric motors, transmitters, etc. even when the cables are shielded.



2 SPECIFICATIONS

	6104	SD-7108	SD-7208	SD-7816	SD-7816B
Function	1:4 SDI Distributor	1:8 SDI Distributor / Deserializer	Serializer, 1:8 SDI Distributor	1:16 or 2x1:8 AES/EBU Distributor	1:16 or 2x1:8 AES/EBU Distributor
Inputs	1 SMPTE-259M Serial Video, 75 ohms on a BNC	1 SMPTE-259M Serial Video, 75 ohms on a BNC	Parallel Digital Video on DB25F connector, ECL levels	Digital Audio, 110 ohm on detachable terminal blocks	Digital Audio, 75 ohm on BNCs
Outputs	4 reclocked SMPTE-259M Serial Video, 75 ohms on BNCs.	8 reclocked SMPTE-259M Serial Video, 75 ohms on BNCs, with adjustable level	8 reclocked SMPTE-259M Serial Video, 75 ohms on BNCs, with adjustable level	16 reclocked digital audio, 110 ohms on detachable terminal blocks	16 reclocked digital audio, 75 ohms on BNCs
Resolution	8 or 10-bits, automatic	8 or 10-bits, automatic	8 or 10-bits, automatic	32-96 kHz sampling frequencies	32-96 kHz sampling frequencies
Standards	143Mb/s (4fsc NTSC) 177Mb/s (4fsc PAL) 270Mb/s (4:2:2 Component) 360Mb/s (4:2:2 Widescreen)	143Mb/s (4fsc NTSC) 177Mb/s (4fsc PAL) 270Mb/s (4:2:2 Component) 360Mb/s (4:2:2 Widescreen)	143Mb/s (4fsc NTSC) 177Mb/s (4fsc PAL) 270Mb/s (4:2:2 Component) 360Mb/s (4:2:2 Widescreen)	AES/EBU, IEC 958, S/PDIF and EIAJ CP340/1201	AES/EBU, IEC 958, S/PDIF and EIAJ CP340/1201
Equalization & reclocking	Automatic up to 30 dB of cable loss	Automatic up to 30 dB of cable loss	Automatic reclocker	Automatic up to 24 dB of cable loss @ 48 kHz	Automatic up to 24 dB of cable loss @ 48 kHz
Control	NA	Output level	Output level	Mode selection, Equalization level	Mode selection, Equalization level
Display	Power ON LED	Operating Standard LEDs	Signal lock LED	Error and DATA existence LEDs for each input channel	Error and DATA existence LEDs for each input channel
Dimensions	12cm X 7.5cm X 2.5cm (4.7" X 3" X 1", W,D,H)	19" 1U, rack mountable	19" 1U, rack mountable	19" 1U, rack mountable	19" 1U, rack mountable
Weight	0.3 kg (0.67 lbs.) Approx.	2.5 kg (5.5 lbs.) Approx	2.5 kg (5.5 lbs.) Approx	2.6 kg (5.7 lbs.) Approx.	2.6 kg (5.7 lbs.) Approx.
Power Source	12 VDC, 250 mA.	230 VAC (115 VAC, U.S.A) 14 VA	230 VAC (115 VAC, U.S.A) 10 VA	230 VAC (115 VAC, U.S.A) 10 VA	230 VAC (115 VAC, U.S.A) 10 VA



3 HOW DO I GET STARTED?

The fastest way to get started is to take your time and do everything right the first time. Taking 15 minutes to read the manual may save you a few hours later. You don't even have to read the whole manual. If a section doesn't apply to you, you don't have to spend your time reading it.

4 UNPACKING AND CONTENTS

The items contained in your Kramer SDI / Digital Audio Distributor package are listed below. Please save the original box and packaging materials for possible future shipment of the accessory.

- **SDI / Digital Audio Distributor**
- **Kramer Concise Product Catalog**
- **Power cord (12 VDC wall transformer/ power supply for the 6104)**
- **This User Manual**
- **Rubber Feet**

5 OPTIONAL ACCESSORIES

The following accessories, which are available from Kramer, can enhance implementation of your distributor. For information regarding cables and additional accessories, contact your Kramer dealer.

SD-7308 – for switching between SDI sources: The machine is a multi-standard, adjustment-free 8x1 switcher for SDI (serial digital) video signals. It accepts up to eight SDI inputs, provides necessary buffering and reclocking, and routes the selected source to four identical SDI outputs using BNC connectors. It provides automatic equalization for losses typical with long runs of 75-ohm co-axial cable. Depending on the cable and video standard, cable length of several hundred meters is possible. Standard recognition is automatic and the machine switches during the vertical interval according to the SMPTE RP-168 standard. A rear-panel output level control is provided to optimize signal level. The input select function of the SD-7308 can be controlled by front panel buttons and by RS-232 commands transmitted by a touch-screen control system, personal computer, or other control system. When no signal exists on a selected input, the LED in the appropriate button flashes. The SD-7308 automatically recognizes the word length for both 10-bit and 8-bit video.

SD-7388 - an adjustment-free, 8x8 matrix switcher for SDI (serial digital) video signals. It is a true matrix allowing any input to be routed to any or all outputs simultaneously. It provides automatic equalization for losses on a 75-ohm co-axial cable, and reclocks each output to provide 8 low-jitter serial digital outputs. Video standard recognition is automatic, and the **SD-7388** switches during the vertical interval. The **SD-7388** accepts either analog or serial video as the external source for its vertical trigger, and any output can be assigned as the sync source. The **SD-7388** can be controlled by front panel buttons, RS-232 and RS-485. It is fully compatible with both 10-bit and 8-bit video, automatically recognizing word length.

SD-7401 - a multi-standard, adjustment-free digital to analog converter designed to accept an SDI (4:4:2 serial digital video) input, and provide analog outputs in four common signal formats. The SDI input is equalized and reclocked, and converted to composite video, S-video (Y/C) and component video (RGsB or Y, R-Y, B-Y) outputs simultaneously. The SD-7401 also has an internal 75% color bar generator, whose timing is based on the SDI input. The SD-7401 encodes 525 line signals to NTSC-M and 625 lines to PAL-B. Versions designed for other standards such as SECAM, PAL-M, and NTSC 4.43 may be available by special request. When encoding NTSC, the unit may be programmed with or without a 7.5 IRE setup (pedestal).

6 SDI AND DIGITAL AUDIO DISTRIBUTORS

This section describes all the controls and connections of your distributor. Understanding the controls and connections helps you realize the full power of your machine.

6.1 Getting to Know Your 6104 Distributor

The Kramer 6104 is an adjustment-free, equalized, reclocking, multi-standard *Serial Video Distribution Amplifier*. The machine provides automatic equalization for losses on the 75-ohm co-axial cable (up to 100s of meters of cable - depending on the cable and the video standard), and reclocks the output to provide 4 low-jitter, serial digital outputs. Standard recognition is automatic, with 4f_{sc} PAL, 4f_{sc} NTSC, Component 4:2:2, and 16:9 (wide-screen) standards being recognized. The machine operates for both 10-bit and 8-bit video, automatically recognizing the word length.

The 6104 is part of the new Kramer DIGITOOOLS family of compact, high quality, and cost-effective solutions for a variety of applications.

Panel features of the 6104 are described in Figure 3 and Table 1.

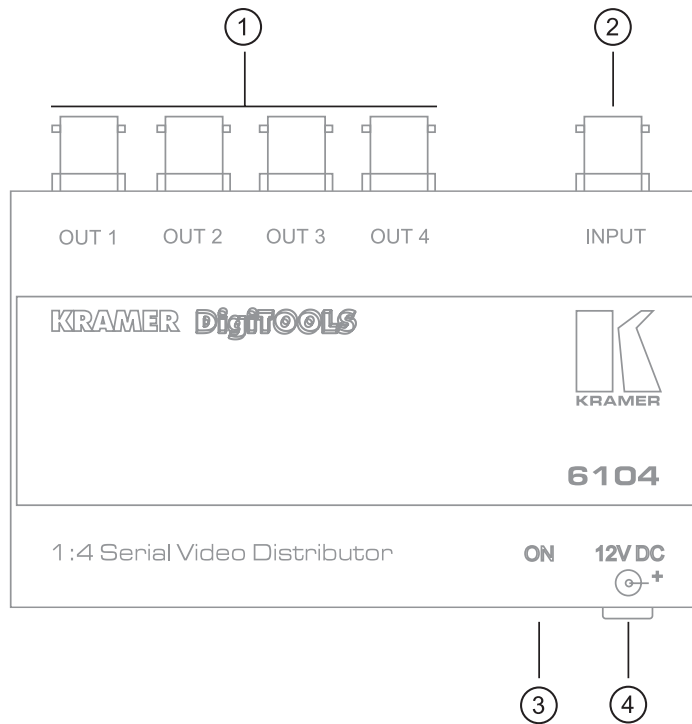

Figure 3: 6104 Front/Rear Panel Features

Table 1: 6104 Front/Rear Panel Features

	Feature	Function
1.	OUT 1-4	4 BNCs for connecting the SDI acceptors
2.	INPUT	SDI input on a BNC connector
3.	ON LED	Indicates that the machine is properly powered
4.	12 VDC	12 Volts DC feed to the machine



6.2 Getting to Know Your SD-7108 Distributor / Deserializer

The Kramer **SD-7108** is an adjustment-free, equalized, reclocking, multi-standard *Serial Video Distribution Amplifier*. In addition, a parallel ECL reclocked output is also provided.

The machine provides automatic equalization for losses on the 75-ohm co-axial cable (up to 100s of meters of cable - depending on the cable and the video standard), and reclocks the output to provide 8 low-jitter, serial digital outputs. Standard recognition is automatic, and front-panel LEDs indicate the detected standard. $4f_{sc}$ PAL, $4f_{sc}$ NTSC, Component 4:2:2, and 16:9 (wide-screen) standards are all recognized. The user may adjust the serial video output level. The *CARRIER* LED indicates the detection of a signal at the input, and the *SYNC* LED shows that horizontal synchronization has been detected. The machine operates for both 10-bit and 8-bit video, automatically recognizing the word length.

Panel features of the **SD-7108** are described in Figure 4 and Table 2.

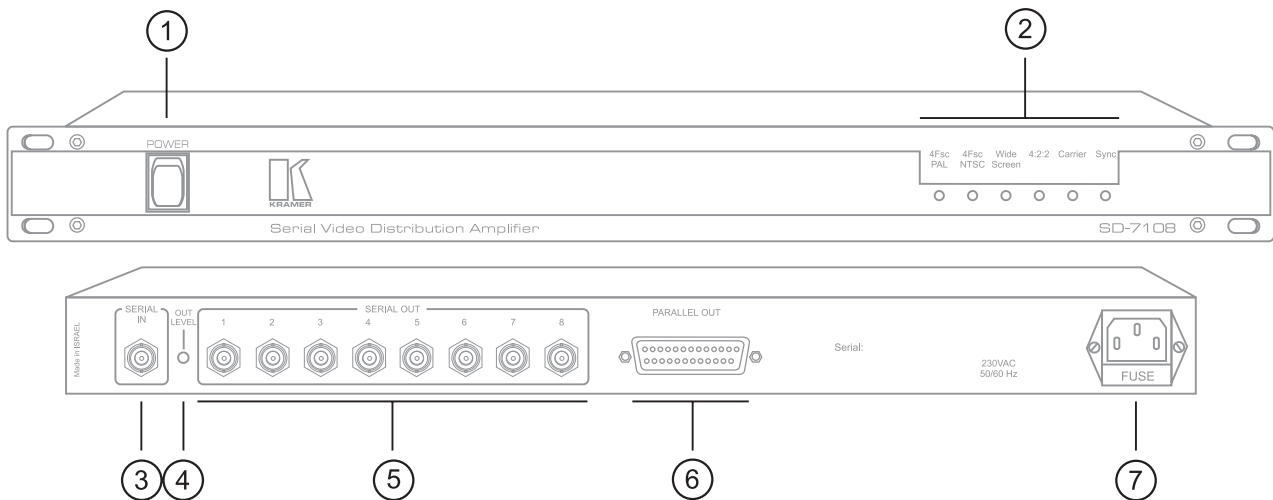

Figure 4: SD-7108 Front/Rear Panel Features

Table 2: SD-7108 Front/Rear Panel Features

	Feature	Function
1.	POWER	Power ON/Off Switch, illuminates when toggled.
2.	LED INDICATORS	LED status indicators
3.	SERIAL IN	SDI input BNC connector
4.	OUT LEVEL	Output level adjustment trimmer
5.	SERIAL OUT	8 SDI outputs on BNCs
6.	PARALLEL OUT	Parallel Digital output on DB-25F connector
7.	POWER SOCKET	A fused socket for connecting the mains power cord

6.3 Getting to Know Your SD-7208 Serializer / Distributor

The Kramer **SD-7208** is an adjustment-free, reclocking, multi-standard *Serializer/SDI Distribution Amplifier*.

The machine embeds the clock and parallel data into an NRZI serial stream according to the SMPTE 259M standard and reclocks the output to provide 8 low-jitter, serial digital outputs. Standard recognition is automatic. A front panel LED indicates locking to the incoming signal. The user may adjust the serial video output level. The machine operates for both 10-bit and 8-bit video, automatically recognizing the word length.

Panel features of the **SD-7208** are described in Figure 5 and Table 3.

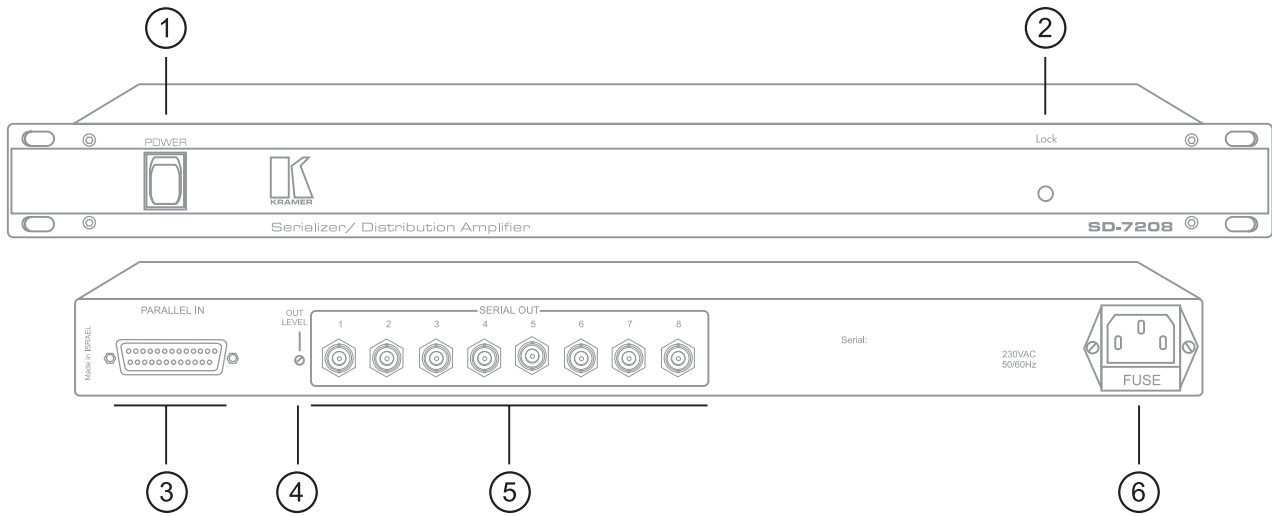

Figure 5: SD-7208 Front/Rear Panel Features

Table 3: SD-7208 Front/Rear Panel Features

	Feature	Function
1.	POWER	Power ON/Off Switch, illuminates when toggled.
2.	LOCK	Signal LOCK indicator LED
3.	PARALLEL IN	Parallel Digital Video input socket on a DB25F connector
4.	OUT LEVEL	Output level adjustment trimmer
5.	SERIAL OUT	8 SDI outputs on BNCs
6.	POWER SOCKET	A fused socket for connecting the mains power cord



6.4 Getting to Know Your SD-7816 Digital Audio Distributor

The Kramer SD-7816 is a high performance, dual mode, distribution amplifier for digital audio signals. The machine can be set to operate as a single-channel 1:16 or as a two-channel 1:8 unit. Several digital formats are supported including AES/EBU, IEC 958, S/PDIF and EIAJ CP340/1201 professional and consumer formats with sampling frequencies up to 96 kHz.

The machine provides 2 inputs, equalized to compensate for losses on twisted pair cables. Reclocking at each input provides 16 low-jitter digital audio outputs. The SD-7816 uses 110-ohm twisted pair cable on detachable terminal block connectors. All inputs and outputs are transformer coupled. The front panel LEDs display the selected setup, the presence of digital audio signals, and the detection of errors in the data stream.

Panel features of the **SD-7816** are described in Figure 6 and Table 4.

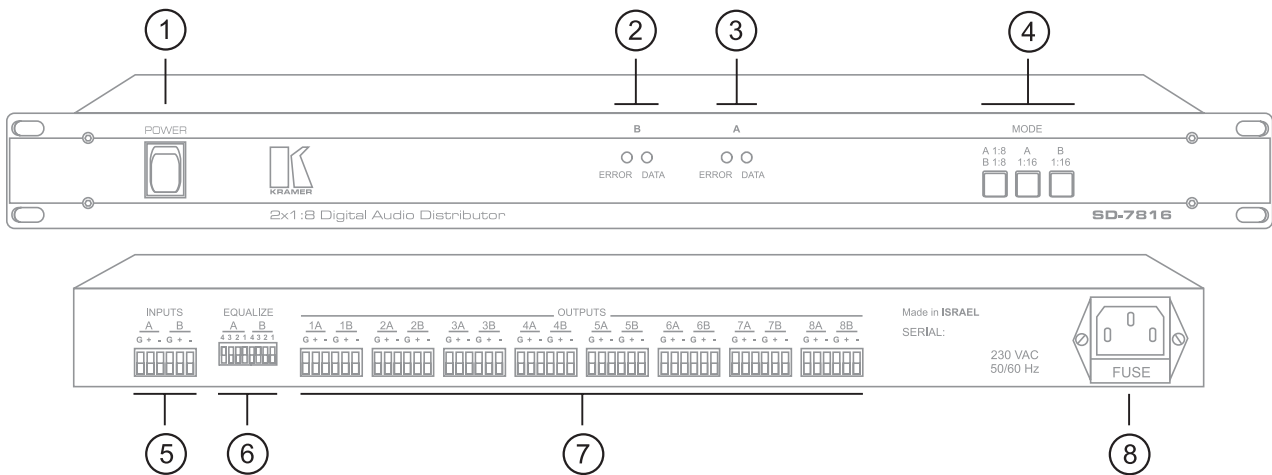

Figure 6: SD-7816 Front/Rear Panel Features

Table 4: SD-7816 Front/Rear Panel Features

	Feature	Function
1.	POWER	Power ON/Off Switch, illuminates when toggled.
2.	ERROR/DATA	Channel B status LEDs
3.	ERROR/DATA	Channel A status LEDs
4.	MODE	Mode select illuminated buttons (2x1:8 or 1:16 operation)
5.	INPUTS	2 differential Digital Audio inputs (110Ω)
6.	EQUALIZE	Equalization control dip-switches for the inputs
7.	OUTPUTS	16 Digital differential Audio outputs on detachable terminal blocks
6.	POWER SOCKET	A fused socket for connecting the mains power cord

6.5 Getting to Know Your SD-7816B Digital Audio Distributor

The Kramer **SD-7816B** is a high performance, dual mode, distribution amplifier for digital audio signals. The machine can be set to operate as a single-channel 1:16 or as a two-channel 1:8 unit. Several digital formats are supported including AES/EBU, IEC 958, S/PDIF and EIAJ CP340/1201 professional and consumer formats with sampling frequencies up to 96 kHz.

The machine provides 2 inputs equalized to compensate for losses on 75-ohm cables. Reclocking at each input provides 16 low-jitter digital audio outputs. The **SD-7816B** is designed for 75-ohm coaxial cables on BNC connectors.

All inputs and outputs are transformer coupled. The front panel LEDs display the selected setup, the presence of digital audio signals, and the detection of errors in the data stream.

Panel features of the **SD-7816B** are described in Figure 7 and Table 5.

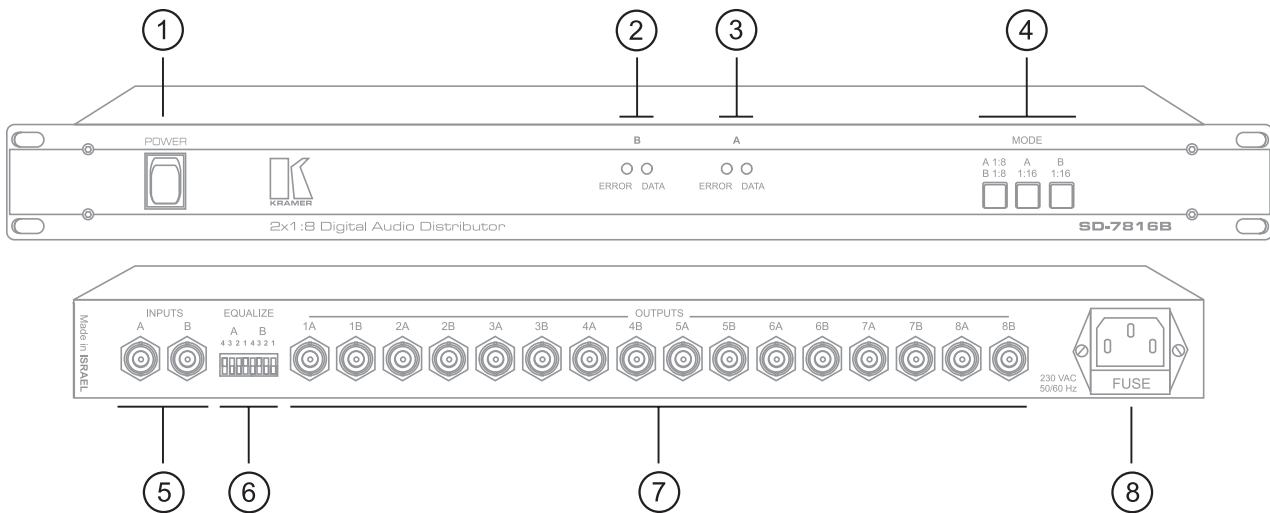

Figure 7: SD-7816B Front/Rear Panel Features

Table 5: SD-7816B Front/Rear Panel Features

	Feature	Function
1.	POWER	Power ON/Off Switch, illuminates when toggled.
2.	ERROR/DATA	Channel B status LEDs
3.	ERROR/DATA	Channel A status LEDs
4.	MODE	Mode select illuminated buttons (2x1:8 or 1:16 operation)
5.	INPUTS	2 single-ended digital audio inputs on BNCs (75Ω)
6.	EQUALIZE	Equalization control dip-switches for the inputs
7.	OUTPUTS	16 Digital single-ended Audio outputs on BNCs
8.	POWER SOCKET	A fused socket for connecting the mains power cord



7 INSTALLATION

8 CONNECTING TO DIGITAL VIDEO DEVICES

Digital video sources and output devices may be connected to the SDI distributors through the BNC type connectors on the back panel. SDI signals are very high frequency carrying signals, and are sensitive to cable quality and length. SDI signals suffer from the “cliff effect” - where the signal might look good after traveling a certain cable length, but when the line is extended with a few inches more - the signal might crash completely, without any warning. Keep the length of the cables at the absolute minimum required!

The machines described in this manual have built in provisions to minimize signal loss and distortions. The SDI inputs have built-in cable equalization circuitries to compensate for high frequency cable losses, as well as “time-base correction” - reclocking circuitries, which eliminate signal jitter accumulated along the cables. The reclocking circuitry regenerates the signals, eliminating signal instability and potential “cliff-effects”. With the built in equalization and reclocking circuitries, the distributors can be operated using cable lengths of hundreds of meters, provided high quality cables are used.

9 CONNECTING TO DIGITAL AUDIO DEVICES

Digital audio sources and output devices may be connected to the Digital Audio Distributors through the detachable terminal block connectors or the BNC type connectors on the back panel. Digital Audio signals have high frequency components, and are thus sensitive to cable quality and length, similar to the SDI signals. Keep the length of the cables at the absolute minimum required! The machines described in this manual have built in provisions to minimize signal loss and distortions. They have built-in cable equalization circuitries to compensate for high frequency cable losses, as well as “time-base correction” - reclocking circuitries, which eliminate signal jitter accumulated along the cables. The reclocking circuitry regenerates the signals clock pulses, eliminating signal instability and potential “cliff-effects”. The **SD-7816** should be used if the digital audio system uses differential (balanced, 110Ω) signals. The **SD-7816B** should be used if the system uses single-ended (unbalanced, 75Ω) signals.

10 TURNING ON THE MACHINE

NOTES

- 1) The machine should only be turned on after all connections are completed and all source devices have been turned on. Do not attempt to connect or disconnect any video signal to the machine while it is turned on.
 - 2) The socket-outlet should be near the equipment and should be easily accessible. To fully disconnect equipment, remove the power supply adapter from the mains socket.
- 1) Connect the machine's mains socket to the wall socket using the power cord (provided with the machine).
 - 2) Operate the source and the acceptors.

10.1 Operation of the SDI Distributors

- ⊗ Connect an SDI source to the BNC input socket of the **6104** or **SD-7108** distributor.
- ⊗ Connect a Parallel digital video source to the DB25 input socket of the **SD-7208**.
- ⊗ Connect up to four (**6104**), or eight (**SD-7108**, **SD-7208**), SDI acceptors to the output sockets of the distributor.
- ⊗ Connect, if required, a Parallel digital video acceptor to the PARALLEL OUT socket of the **SD-7108**.
- ⊗ Adjust, only if required, the SDI output levels (**SD-7108**, **SD-7208**) using an insulated screwdriver. Bear in mind the machines are factory pre-adjusted for 1:1 transparency, and unnecessarily trimming the output level will upset this transparency.

10.2 Operation of the Digital Audio Distributors

For AES/EBU twisted pair connections (as defined by AES3-1992 standard) the **SD-7816** DA should be used. The signal is bi-phase coded, transformer coupled and transmitted in a balanced format on shielded twisted pair wires. The signal level may be 2 to 7 volts peak to peak with a source impedance of 110 ohms. The interconnecting cable should exhibit nominal 110 ohms characteristic impedance. When connecting the source and the acceptors, special attention should be paid to the polarity of the connections.

Measure the level of the input signal using an oscilloscope, (excluding overshoots and undershoots) as shown in figure 8. Using this value, set the DIP-switches according to Table 6. (Table 6 is based on the graph in figure 9 - "Professional format: 110 ohm, Balanced").

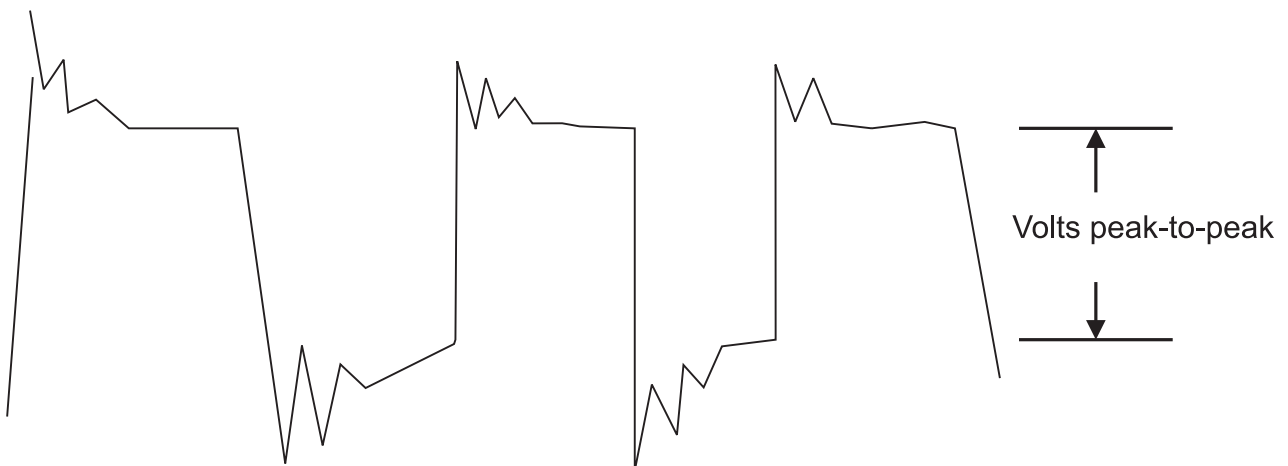

Figure 8: Signal peak-to-peak measurement

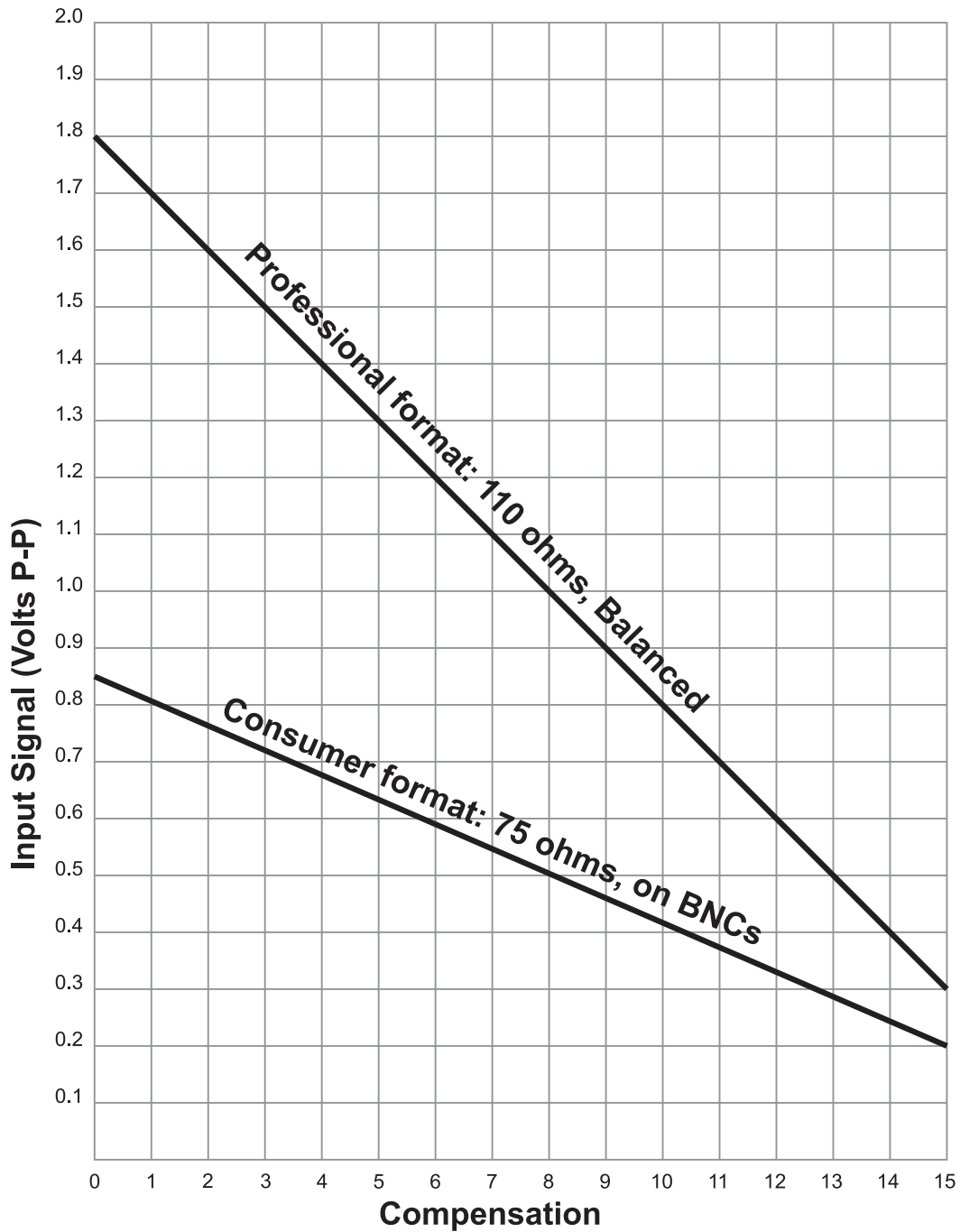

Figure 9: Compensation level

The AES and SMPTE committees established the standard interface for transmission of AES/EBU data on **coaxial** cable, sometimes referred to as AES3-ID. For this type of interface, the **SD-7816B** should be used. The signal is bi-phase coded, transformer coupled and transmitted over a coaxial cable in a single ended format. The signal level is 1.0 volts peak to peak with a source impedance of 75 ohms. The interconnecting cable should also exhibit a nominal 75 ohms characteristic impedance. After all the connections have been made, turn on the source signals units and the **SD-7816B** and measure, using an oscilloscope, the signal level - directly on the input connectors of the **SD-7816B** as described above. Using this value, set the DIP-switches according to Table 6. (Table 6 is based on the graph in figure 9 - “Consumer format – 75 ohms, on BNCs”).



Professional format: 110 ohm, Balanced					Consumer format: 75 ohms, on BNCs				
Measured value, Volts (p-p)	DIP SWITCH SETTING				Measured value, Volts (p-p)	DIP SWITCH SETTING			
	4	3	2	1		4	3	2	1
1.8v and above	OFF	OFF	OFF	OFF	0.9v and above	OFF	OFF	OFF	OFF
1.7V	OFF	OFF	OFF	ON	0.82V	OFF	OFF	OFF	ON
1.6v	OFF	OFF	ON	OFF	0.77V	OFF	OFF	ON	OFF
1.5V	OFF	OFF	ON	ON	0.72V	OFF	OFF	ON	ON
1.4V	OFF	ON	OFF	OFF	0.68V	OFF	ON	OFF	OFF
1.3V	OFF	ON	OFF	ON	0.64V	OFF	ON	OFF	ON
1.2V	OFF	ON	ON	OFF	0.60V	OFF	ON	ON	OFF
1.1V	OFF	ON	ON	ON	0.55V	OFF	ON	ON	ON
1.0V	ON	OFF	OFF	OFF	0.50V	ON	OFF	OFF	OFF
0.9V	ON	OFF	OFF	ON	0.46V	ON	OFF	OFF	ON
0.8V	ON	OFF	ON	OFF	0.41V	ON	OFF	ON	OFF
0.7V	ON	OFF	ON	ON	0.37V	ON	OFF	ON	ON
0.6V	ON	ON	OFF	OFF	0.33V	ON	ON	OFF	OFF
0.5V	ON	ON	OFF	ON	0.29V	ON	ON	OFF	ON
0.4V	ON	ON	ON	OFF	0.24V	ON	ON	ON	OFF
0.3V	ON	ON	ON	ON	0.20V	ON	ON	ON	ON

Table 6: Dip-Switch settings for signal level compensation

10.2.1 PROGRAMMING

The mode of operation (programming) is selected by activating one of the touch buttons marked **A:8/B:8**, **A:16**, **B:16**.

The programming buttons illuminate when pressed and function as follows:

A:8/B:8 – splits input A to outputs 1A – 8A and input B to outputs 1B – 8B respectively.

A:16 – splits input A to all outputs 1A – 8A and 1B – 8B

B:16 – splits input B to all outputs 1A – 8A and 1B – 8B

10.2.2 INDICATION

Each channel has two status LEDs. The GREEN one indicates the presence of data and the RED one indicates an ERROR within the digital audio signal. When a valid digital audio signal is detected, the corresponding GREEN LED is lit. The RED LED may light up when there is no signal on the corresponding input (GREEN LED off). When the RED LED is lit together with the GREEN LED, it is an indication that the signal at the input is either a non-standard signal or it has errors. For normal operation, the GREEN LED is lit and RED LED is unlit.

The built-in “watch dog” circuitry checks each and every frame of the digital audio signal. If an ERROR appears in a frame, the RED LED is illuminated for about half a second.

11 TAKING CARE OF YOUR MACHINE

Do not locate your machine in an environment where it is susceptible to dust or moisture. Both of these may damage the electronics, and cause erratic operation or failure. Do not locate your machine where temperature and humidity may be excessive. Doing so may also damage the electronics, and cause erratic operation or failure of your machine. Do not clean your machine with abrasives or strong cleaners. Doing so may remove or damage the finish, or may allow moisture to build up. Take care not to allow dust or particles to build up inside unused or open connectors.



12 TROUBLESHOOTING

NOTES

1. Please note that if the output signal is disturbed or interrupted by very strong external electromagnetic interference, it should return and stabilize when such interference ends. If not, disconnect power from the machine and reconnect again to reset the machine.
2. If the following recommended actions still do not result in satisfactory operation, please consult your KRAMER Dealer.

12.1 Power and Indicators

Problem	Remedy
No Power	<ol style="list-style-type: none">1. For the SD-7108, SD-7208, SD-7816 and SD-7816B, confirm that the rocker switch is in the “ON” position, and that the switch is illuminated.2. For the SD-7108, SD-7208, SD-7816 and SD-7816B, confirm that power connections are secured at the machine and at the receptacle. Make sure the mains receptacle is active. If still there is no power, remove power cord from AC outlet and then, using a flat head screwdriver, remove the fuse holder located directly below the power connector on your machine. Confirm that the fuse is good by looking for the wire connected between the ends of the fuse. If the wire is broken, replace the fuse with another, with the same rating.3. For the 6104 – check for proper DC polarity, and if needed, carefully remove the cover of the machine and check the on-board fuse. Replace the fuse with an identical-value fuse if necessary.

12.2 SDI and Digital Audio Signals

Problem	Remedy
No video or audio at the output device.	<ol style="list-style-type: none">1. Confirm that your source and output devices are turned on and connected properly. The input of your machine should be of an identical signal format or standard as the output of your source. Signals at the output of your machine should be of an identical signal format or standard as at the input of your display or acceptor.2. Confirm that any other device in the signal path has the proper input and/or output selected.3. Confirm that the maximum cable length was not exceeded. Disappearance of the SDI or the Digital Audio signals may be a result of the “cliff effect”.



LIMITED WARRANTY

Kramer Electronics (hereafter Kramer) warrants this product free from defects in material and workmanship under the following terms.

HOW LONG IS THE WARRANTY

Labor and parts are warranted for three years from the date of the first customer purchase.

WHO IS PROTECTED

Only the first purchase customer may enforce this warranty.

WHAT IS COVERED AND WHAT IS NOT COVERED

Except as below, this warranty covers all defects in material or workmanship in this product.

The following are not covered by the warranty:

- 1) Any product which is not distributed by Kramer or which is not purchased from an authorized Kramer dealer. If you are uncertain as to whether a dealer is authorized, please contact Kramer at one of the agents listed in the web site www.kramerelectronics.com.
- 2) Any product, on which the serial number has been defaced, modified or removed.
- 3) Damage, deterioration or malfunction resulting from:
 - a) Accident, misuse, abuse, neglect, fire, water, lightning or other acts of nature.
 - b) Unauthorized product modification, or failure to follow instructions supplied with the product.
 - c) Repair or attempted repair by anyone not authorized by Kramer.
 - d) Any shipment of the product (claims must be presented to the carrier).
 - e) Removal or installation of the product.
 - f) Any other cause, which does not relate to a product defect.
 - g) Cartons, equipment enclosures, cables or accessories used in conjunction with the product.

WHAT WE WILL PAY FOR AND WHAT WE WILL NOT PAY FOR

We will pay labor and material expenses for covered items. We will not pay for the following:

- 1) Removal or installations charges.
- 2) Costs of initial technical adjustments (set-up), including adjustment of user controls or programming. These costs are the responsibility of the Kramer dealer from whom the product was purchased.
- 3) Shipping charges.

HOW YOU CAN GET WARRANTY SERVICE

- 1) To obtain service on you product, you must take or ship it prepaid to any authorized Kramer service center.
- 2) Whenever warranty service is required, the original dated invoice (or a copy) must be presented as proof of warranty coverage, and should be included in any shipment of the product. Please also include in any mailing a contact name, company, address, and a description of the problem(s).
- 3) For the name of the nearest Kramer authorized service center, consult your authorized dealer.



LIMITATION OF IMPLIED WARRANTIES

All implied warranties, including warranties of merchantability and fitness for a particular purpose, are limited in duration to the length of this warranty.

EXCLUSION OF DAMAGES

Kramer's liability for any defective products is limited to the repair or replacement of the product at our option. Kramer shall not be liable for:

- 1) Damage to other property caused by defects in this product, damages based upon inconvenience, loss of use of the product, loss of time, commercial loss; or:
- 2) Any other damages, whether incidental, consequential or otherwise. Some countries may not allow limitations on how long an implied warranty lasts and/or do not allow the exclusion or limitation of incidental or consequential damages, so the above limitations and exclusions may not apply to you.

This warranty gives you specific legal rights, and you may have other rights, which vary from place to place.

NOTE: All products returned to Kramer for service must have prior approval. This may be obtained from your dealer.

NOTICE

This equipment has been tested to determine compliance with the requirements of:

- | | |
|-----------|---|
| EN-50081: | "Electromagnetic compatibility (EMC);
generic emission standard.
Part 1: Residential, commercial and light industry" |
| EN-50082: | "Electromagnetic compatibility (EMC) generic immunity standard.
Part 1: Residential, commercial and light industry environment". |
| CFR-47 | FCC Rules and Regulations:
Part 15- "Radio frequency devices:
Subpart B- Unintentional radiators |

CAUTION

- Servicing of the above mentioned machines is only allowed to a Kramer authorized technician or Engineer. Any user who makes changes or modifications to the unit without the express approval of the manufacturer will void user authority to operate the equipment.
- Use the DC power supply (provided) to supply power to the machine and controllers.
- Please use recommended interconnect cables to connect the machine to controllers and other components.



**The list of Kramer distributors appears on our web site:
www.kramerelectronics.com
From the web site it is also possible to e-mail factory headquarters.
We welcome your questions, comments and feedback.**

KRAMER ELECTRONICS, LTD.

3 Am VeOlamo Street. Jerusalem 95463, Israel Tel: (972-2)-654-4000. Fax: (972-2)-653-5369
E-mail: kramerel@netvision.net.il