

Kramer Electronics, Ltd.

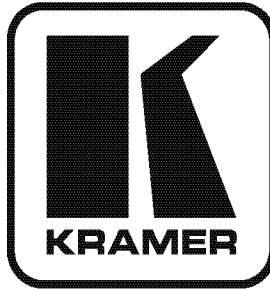

USER MANUAL

Model:

VM-12HDCP

1:12 DVI Distributor

Contents

1	Introduction	1
2	Getting Started	1
2.1	Quick Start	1
3	Overview	3
3.1	About HDCP	3
3.2	Defining EDID	4
3.3	Recommendations for Best Performance	4
4	Your VM-12HDCP 1:12 DVI Distributor	4
5	Installing the VM-12HDCP on a Rack	7
6	Connecting a VM-12HDCP 1:12 DVI Distributor	8
7	Acquiring EDID	9
7.1	The Simple Operation State	9
7.2	The Normal Operation State	9
7.2.1	Acquiring the EDID from a Selected Output	9
7.2.2	Restoring the Default EDID	10
7.2.3	Acquiring the Auto EDID	10
8	Technical Specifications	10

Figures

Figure 1:	VM-12HDCP 1:12 DVI Distributor	5
Figure 2:	Connecting a VM-12HDCP 1:12 DVI Distributor	8

Tables

Table 1:	VM-12HDCP 1:12 DVI Distributor Features	6
Table 2:	Technical Specifications of the VM-12HDCP 1:12 DVI Distributor	10

1 Introduction

Welcome to Kramer Electronics! Since 1981, Kramer Electronics has been providing a world of unique, creative, and affordable solutions to the vast range of problems that confront the video, audio, presentation, and broadcasting professional on a daily basis. In recent years, we have redesigned and upgraded most of our line, making the best even better! Our 500-plus different models now appear in eight groups¹ that are clearly defined by function.

Congratulations on purchasing your Kramer **VM-12HD**CP 1:12 DVI Distributor. The **VM-12HD**CP is ideal for:

- Multiple screen applications
- Rental and staging

Each package includes the following items:

- **VM-12HD**CP 1:12 DVI Distributor
- Power cord²
- This user manual³

2 Getting Started

We recommend that you:

- Unpack the equipment carefully and save the original box and packaging materials for possible future shipment
- Review the contents of this user manual
- Use Kramer high performance high resolution cables⁴

2.1 Quick Start

This quick start chart summarizes the basic setup and operation steps.

1 GROUP 1: Distribution Amplifiers; GROUP 2: Video and Audio Switchers, Matrix Switchers and Controllers; GROUP 3: Video, Audio, VGA/XGA Processors; GROUP 4: Interfaces and Sync Processors; GROUP 5: Twisted Pair Interfaces; GROUP 6: Accessories and Rack Adapters; GROUP 7: Scan Converters and Sealers; and GROUP 8: Cables and Connectors

2 We recommend that you use only the power cord that is supplied with this machine

3 Download up-to-date Kramer user manuals from our Web site at <http://www.kramerelectronics.com>

4 The complete list of Kramer cables is on our Web site at <http://www.kramerelectronics.com>

Step 1: Mount the machine - see section 5

Mount the machine in a rack or stick the 4 rubber feet to the underside

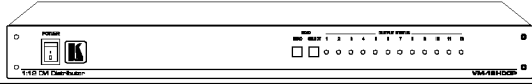

Step 2: Connect the input and outputs - see section 6

- 1 Connect the Input
- 2 Connect the outputs

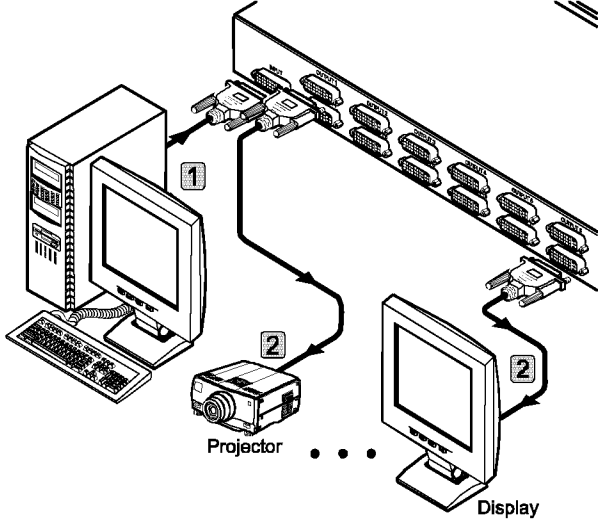

Step 3: Turn the power ON

Step 4: Acquire EDID - see section 7

SET THE OPERATION STATE

To access the Normal operation state, turn the machine ON while pressing the SELECT button

To access the Simple operation state, turn the machine ON while pressing the READ button

Acquire the EDID from:

- A connected output
- Several connected outputs
- The default EDID

The default EDID is sent to the input automatically

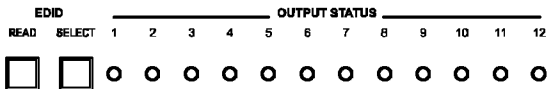

3 Overview

The Kramer **VM-12HDCP** is an HDCP¹ (High-Bandwidth Digital Content Protection) compatible 1:12 distribution amplifier for DVI-D (Digital) signals. Since high-resolution DVI signals are very sensitive to cable quality and to PCB layout, the **VM-12HDCP** uses a uniquely designed PCB which includes all buffering, conditioning and amplifying circuitry to provide 12 high-level output signals.

In particular, the **VM-12HDCP**:

- Distributes signals having resolutions up to UXGA, including all HDTV formats
- Has a bandwidth of 1.65Gbps
- Supports the DDWG DVI 1.0 standard
- Consists of a built-in re-clocking block that re-generates the DVI signal, so that several units may be cascaded
- Can read and store, in non-volatile memory, the EDID² block from one or more outputs, so it can then provide the EDID information to the DVI source even if the display device is not connected
- Stores a default EDID for fast and efficient connection of the unit³
- Has 13 DVI-I connectors, which are compatible with all types of DVI cables
- Is a cost-effective solution for distributing the TMDS signals used for DVI, and uses state-of-the-art line drivers on each of the 12 outputs

The **VM-12HDCP** fits in one vertical space of a standard 19" professional rack enclosure (1U).

3.1 About HDCP

The High-Bandwidth Digital Content Protection (HDCP) standard⁴, protects digital video and audio signals transmitted over DVI or HDMI connections between two HDCP-enabled devices to eliminate the reproduction of copyrighted material. To protect copyright holders (such as movie studios) from having their programs copied and shared, the HDCP standard provides for the secure, encrypted transmission of digital signals.

1 Note that Kramer Electronics Limited is an HDCP Licensee, see <http://www.digital-cp.com/list/>

2 EDID is Extended Display Identification Data

3 The default EDID feature lets you connect the VM-12HDCP without having to connect a display to the output

4 Developed by Intel

3.2 Defining EDID

The Extended Display Identification Data (EDID¹) is a data-structure, provided by a display, to describe its capabilities to the source. The EDID enables the **VM-12HDCP** to “know” what kind of monitor is connected to the output. The EDID includes the manufacturer’s name, the product type, the timing data supported by the display, the display size, luminance data and (for digital displays only) the pixel mapping data.

3.3 Recommendations for Best Performance

Achieving the best performance means:

- Connecting only good quality connection cables, thus avoiding interference, deterioration in signal quality due to poor matching, and elevated noise levels (often associated with low quality cables)
- Avoiding interference from neighboring electrical appliances and positioning your **VM-12HDCP** away from moisture, excessive sunlight and dust

4 Your VM-12HDCP 1:12 DVI Distributor

Figure 1 and Table 1 define the **VM-12HDCP 1:12 DVI Distributor**:

¹ Defined by a standard published by the Video Electronics Standards Association (VESA)

Your VM-12HDCP 1:12 DVI Distributor

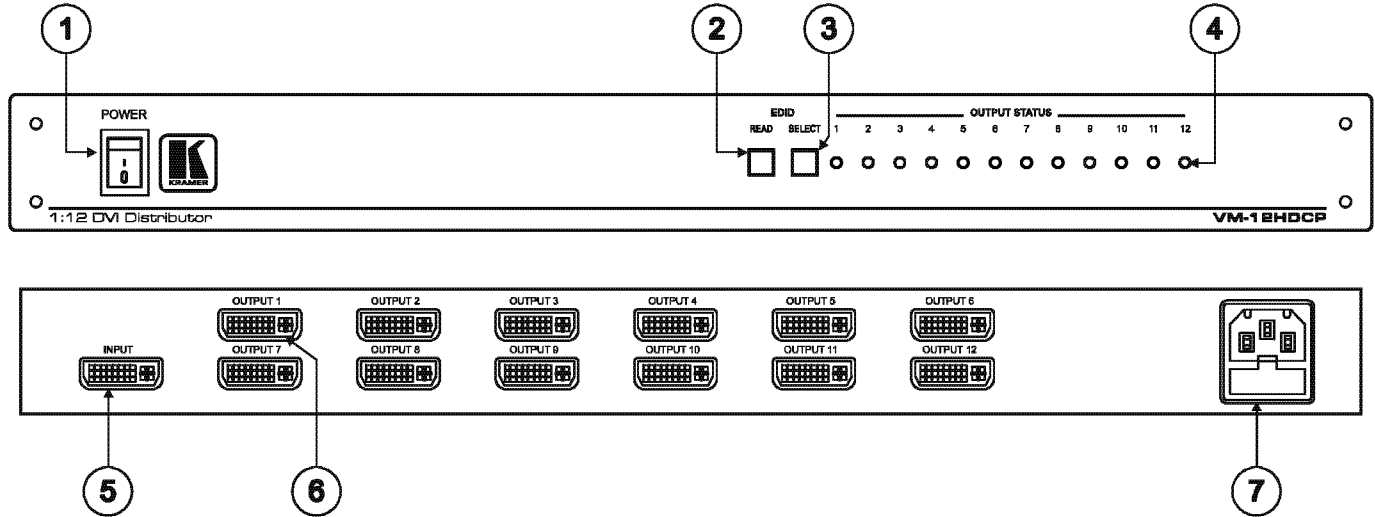

Figure 1: VM-12HDCP 1:12 DVI Distributor

Table 1: VM-12HDCP 1:12 DVI Distributor Features

#	Feature	Function
1	POWER Switch	Illuminated switch for turning the unit ON or OFF
2	EDID	READ Button
3		SELECT Button
4	OUTPUT STATUS LEDs (from 1 to 12)	LEDs light when an output(s) is connected and active; LEDs blink when selecting EDID (see section 7)
5	INPUT DVI Connector	Connect to the DVI source
6	OUTPUT DVI Connectors	Connect to the DVI acceptors (from 1 to 12)
7	Power Connector with Fuse	AC connector enabling power supply to the unit

5 Installing the VM-12HDCP on a Rack

This section describes what to do before installing on a rack and how to rack mount.

Before Installing on a Rack

Before installing on a rack, be sure that the environment is within the recommended range:	
Operating temperature range	+5° to +45° C (41° to 113° F)
Operating humidity range	10 to 90% RHL, non-condensing
Storage temperature range	-20° to +70° C (-4° to 158° F)
Storage humidity range	5 to 95% RHL, non-condensing



CAUTION!!

When installing on a 19" rack, avoid hazards by taking care that:

1. It is located within the recommended environmental conditions, as the operating ambient temperature of a closed or multi unit rack assembly may exceed the room ambient temperature.
2. Once rack mounted, enough air will still flow around the machine.
3. The machine is placed straight in the correct horizontal position.
4. You do not overload the circuit(s). When connecting the machine to the supply circuit, overloading the circuits might have a detrimental effect on overcurrent protection and supply wiring. Refer to the appropriate nameplate ratings for information. For example, for fuse replacement, see the value printed on the product label.
5. The machine is earthed (grounded) in a reliable way and is connected only to an electricity socket with grounding. Pay particular attention to situations where electricity is supplied indirectly (when the power cord is not plugged directly into the socket in the wall), for example, when using an extension cable or a power strip, and that you use only the power cord that is supplied with the machine.

How to Rack Mount

To rack-mount a machine:

1. Attach both ear brackets to the machine. To do so, remove the screws from each side of the machine (3 on each side), and replace those screws through the ear brackets.

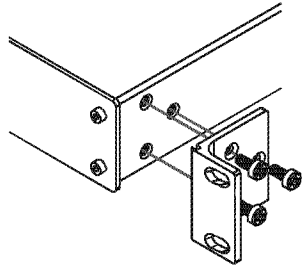

2. Place the ears of the machine against the rack rails, and insert the proper screws (not provided) through each of the four holes in the rack ears.

Note that:

- In some models, the front panel may feature built-in rack ears
- Detachable rack ears can be removed for desktop use
- Always mount the machine in the rack before you attach any cables or connect the machine to the power
- If you are using a Kramer rack adapter kit (for a machine that is not 19"), see the Rack Adapters user manual for installation instructions (you can download it at: <http://www.kramerelectronics.com>)

6 Connecting a VM-12HDCP 1:12 DVI Distributor

To connect the **VM-12HDCP** as illustrated in the example in Figure 2, do the following¹:

1. Connect a DVI source (for example, a computer) to the INPUT connector.
2. Connect up to 12 OUTPUT connectors² to up to 12 DVI acceptors. For example, the:
 - OUTPUT 1 connector to DVI acceptor 1 (for example, a projector)
 - OUTPUT 12 connector to DVI acceptor 12 (for example, a display)
3. Connect the power cord to the mains electricity (not shown in Figure 2).

To use the **VM-12HDCP**, do the following:

1. Turn ON the POWER.
2. Acquire the EDID (see section 7).

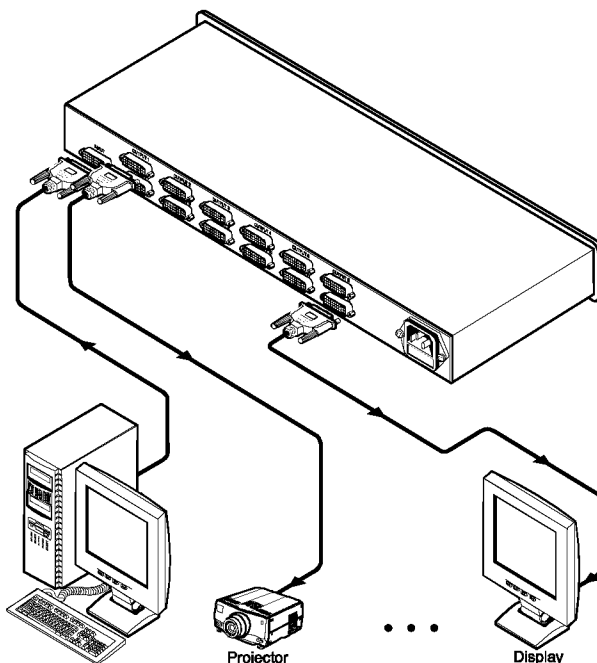

Figure 2: Connecting a VM-12HDCP 1:12 DVI Distributor

1 Switch OFF the power on each device before connecting it to your VM-12HDCP. After connecting your VM-12HDCP, switch on its power and then switch on the power on each device

2 Not all the outputs need to be connected

7 Acquiring EDID

The **VM-12HDCP** initially operates with the default EDID. This means that you can turn ON the power before connecting any of the acceptors or the source.

This section describes the two EDID operation states:

- Simple (see section 7.1)
- Normal (see section 7.2)

7.1 The Simple Operation State

In the Simple operation state, the READ and SELECT front panel buttons are disabled, and the default EDID is passed directly to the input.

To enter the Simple Operation State, turn the machine ON while pressing the READ button.
LEDS 3 and 4 blink three times

7.2 The Normal Operation State

In the Normal operation state, you can toggle between the following working modes:

- Sending the EDID from a selected output to the input (see section 7.2.1)
- Sending the default EDID to the input (see section 7.2.2)
- Sending the auto¹ EDID to the input (see section 7.2.3)

To enter the Normal Operation State, turn the machine ON while pressing the SELECT button.
LEDS 1 and 2 blink three times

7.2.1 Acquiring the EDID from a Selected Output

To select an EDID from a selected output, do the following:

1. Press the SELECT button, as required, to reach the desired output, which blinks.
2. Press the READ button.

The EDID of the selected output is stored in the non-volatile memory when the READ button no longer illuminates as well as the selected output LED.

¹ The auto EDID is an adjusted calculation of the EDIDs of all the connected outputs

7.2.2 Restoring the Default EDID

To restore the default EDID, do the following:

1. Press the SELECT button several times until the OUTPUT LEDs blink simultaneously.
2. Press the READ button.
The READ button illuminates.
The default EDID is stored in the non-volatile memory when the READ button no longer illuminates as well as the output LEDs.

7.2.3 Acquiring the Auto EDID

To acquire the Auto EDID, do the following:

1. Press the SELECT button several times until the OUTPUT LEDs blink in sequence.
2. Press the READ button.
The READ button illuminates.
The auto EDID is stored in the non-volatile memory when the READ button no longer illuminates as well as the output 1 LED.

8 Technical Specifications

Table 2 includes the technical specifications:

Table 2: Technical Specifications¹ of the VM-12HDCP 1:12 DVI Distributor

INPUT:	1 DVI, 1.2Vpp on a DVI Molex 24pin female connector; DDC signal 5Vpp (TTL)
OUTPUTS:	12 DVI, 1.2Vpp on DVI Molex 24pin female connectors; DDC signal 5Vpp (TTL)
BANDWIDTH:	1.65Gbps
CONTROLS:	SELECT and READ buttons for selecting and storing EDID information
POWER SOURCE:	100-240 VAC, 50/60Hz 11VA
DIMENSIONS:	19-inch (W), 7-inch (D), 1U (H)
WEIGHT:	2.5 kg. (5.5 lbs.) approx.
ACCESSORIES:	Power cord
OPTIONS:	Kramer DVI cables ²

¹ Specifications are subject to change without notice

² The complete list of Kramer cables is on our Web site at <http://www.kramerelectronics.com>

LIMITED WARRANTY

Kramer Electronics (hereafter *Kramer*) warrants this product free from defects in material and workmanship under the following terms.

HOW LONG IS THE WARRANTY

Labor and parts are warranted for seven years from the date of the first customer purchase.

WHO IS PROTECTED?

Only the first purchase customer may enforce this warranty.

WHAT IS COVERED AND WHAT IS NOT COVERED

Except as below, this warranty covers all defects in material or workmanship in this product. The following are not covered by the warranty:

1. Any product which is not distributed by Kramer, or which is not purchased from an authorized Kramer dealer. If you are uncertain as to whether a dealer is authorized, please contact Kramer at one of the agents listed in the Web site www.kramerelectronics.com.
2. Any product, on which the serial number has been defaced, modified or removed, or on which the WARRANTY VOID IF TAMPERED sticker has been torn, reattached, removed or otherwise interfered with.
3. Damage, deterioration or malfunction resulting from:
 - i) Accident, misuse, abuse, neglect, fire, water, lightning or other acts of nature
 - ii) Product modification, or failure to follow instructions supplied with the product
 - iii) Repair or attempted repair by anyone not authorized by Kramer
 - iv) Any shipment of the product (claims must be presented to the carrier)
 - v) Removal or installation of the product
 - vi) Any other cause, which does not relate to a product defect
 - vii) Cartons, equipment enclosures, cables or accessories used in conjunction with the product

WHAT WE WILL PAY FOR AND WHAT WE WILL NOT PAY FOR

We will pay labor and material expenses for covered items. We will not pay for the following:

1. Removal or installations charges.
2. Costs of initial technical adjustments (set-up), including adjustment of user controls or programming. These costs are the responsibility of the Kramer dealer from whom the product was purchased.
3. Shipping charges.

HOW YOU CAN GET WARRANTY SERVICE

1. To obtain service on you product, you must take or ship it prepaid to any authorized Kramer service center.
2. Whenever warranty service is required, the original dated invoice (or a copy) must be presented as proof of warranty coverage, and should be included in any shipment of the product. Please also include in any mailing a contact name, company, address, and a description of the problem(s).
3. For the name of the nearest Kramer authorized service center, consult your authorized dealer.

LIMITATION OF IMPLIED WARRANTIES

All implied warranties, including warranties of merchantability and fitness for a particular purpose, are limited in duration to the length of this warranty.

EXCLUSION OF DAMAGES

The liability of Kramer for any effective products is limited to the repair or replacement of the product at our option. Kramer shall not be liable for:

1. Damage to other property caused by defects in this product, damages based upon inconvenience, loss of use of the product, loss of time, commercial loss; or:
2. Any other damages, whether incidental, consequential or otherwise. Some countries may not allow limitations on how long an implied warranty lasts and/or do not allow the exclusion or limitation of incidental or consequential damages, so the above limitations and exclusions may not apply to you.

This warranty gives you specific legal rights, and you may also have other rights, which vary from place to place.

NOTE: All products returned to Kramer for service must have prior approval. This may be obtained from your dealer.

This equipment has been tested to determine compliance with the requirements of:

- EN-50081: "Electromagnetic compatibility (EMC); generic emission standard.
Part 1: Residential, commercial and light industry"
- EN-50082: "Electromagnetic compatibility (EMC) generic immunity standard.
Part 1: Residential, commercial and light industry environment".
- CFR-47: FCC Rules and Regulations:
Part 15: "Radio frequency devices
Subpart B Unintentional radiators"

CAUTION!

- Servicing the machines can only be done by an authorized Kramer technician. Any user who makes changes or modifications to the unit without the expressed approval of the manufacturer will void user authority to operate the equipment.
- Use the supplied DC power supply to feed power to the machine.
- Please use recommended interconnection cables to connect the machine to other components.





For the latest information on our products and a list of Kramer distributors, visit our Web site: www.kramerelectronics.com, where updates to this user manual may be found. We welcome your questions, comments and feedback.

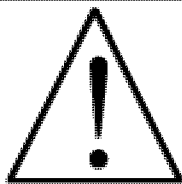

Caution

Safety Warning:

Disconnect the unit from the power supply before opening/servicing.



Kramer Electronics, Ltd.

Web site: www.kramerelectronics.com

E-mail: info@kramerel.com

P/N: 2900-000368 REV 1