

Crestron **Adagio™ AES**  
Entertainment System

---

Operations Guide



This document was prepared and written by the Technical Documentation department at:



Crestron Electronics, Inc.  
15 Volvo Drive  
Rockleigh, NJ 07647  
1-888-CRESTRON

## Important Safety Instructions

- Read these instructions.
- Keep these instructions.
- Heed all warnings.
- Follow all instructions.
- Do not use this apparatus near water.
- Clean only with dry cloth.
- Do not block any ventilation openings. Install in accordance with the manufacturer's instructions.
- Do not install near any heat sources such as radiators, heat registers, stoves, or other apparatus (including amplifiers) that produce heat.
- Do not defeat the safety purpose of the polarized or grounding-type plug. A polarized plug has two blades with one wider than the other. A grounding-type plug has two blades and a third grounding prong. The wide blade or the third prong are provided for your safety. If the provided plug does not fit into your outlet, consult an electrician for replacement of the obsolete outlet.
- Protect the power cord from being walked on or pinched particularly at plugs, convenience receptacles, and the point where they exit from the apparatus.
- Only use attachments/accessories specified by the manufacturer.
- Unplug this apparatus during lightning storms or when unused for long periods of time.
- Refer all servicing to qualified service personnel. Servicing is required when the apparatus has been damaged in any way, such as power-supply cord or plug is damaged, liquid has been spilled or objects have fallen into the apparatus, the apparatus has been exposed to rain or moisture, does not operate normally, or has been dropped.
- Disconnect power prior to connecting or disconnecting equipment.
- Do not install in direct sunlight.
- The apparatus must be installed in a way that the power cord can be removed either from the wall outlet or from the device itself in order to disconnect the mains power.
- Prevent foreign objects from entering the device.

### WARNING:

TO REDUCE THE RISK OF FIRE OR ELECTRIC SHOCK, DO NOT EXPOSE THIS APPARATUS TO RAIN OR MOISTURE. THE APPARATUS SHALL NOT BE EXPOSED TO DRIPPING OR SPLASHING. OBJECTS FILLED WITH LIQUIDS, SUCH AS VASES, SHOULD NOT BE PLACED ON THE APPARATUS.

### WARNING:

TO PREVENT ELECTRIC SHOCK, DO NOT REMOVE COVER. THERE ARE NO USER SERVICEABLE PARTS INSIDE. ONLY QUALIFIED SERVICE PERSONNEL SHOULD PERFORM SERVICE.

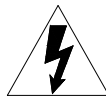

The lightning flash with arrowhead symbol, within an equilateral triangle, is intended to alert the user to the presence of uninsulated "dangerous voltage" within the product's enclosure that may be of sufficient magnitude to constitute a risk of electric shock to persons.

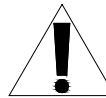

The exclamation point within an equilateral triangle is intended to alert the user to the presence of important operating and maintenance (servicing) instructions in the literature accompanying the appliance.

### WARNING:

THIS IS AN APPARATUS WITH CLASS I CONSTRUCTION. IT SHALL BE CONNECTED TO AN ELECTRICAL OUTLET WITH AN EARTHING GROUND TERMINAL.

### IMPORTANT:

The AES can be used with Class 2 output wiring.

# Contents

<b>Entertainment System: Adagio AES</b>	<b>1</b>
Introduction .....	1
Features and Functions .....	1
Multi-Room Audio .....	2
High-End Performance.....	2
Enhanced Front Panel Control .....	2
Preset Groups .....	2
Versatile Room Controls.....	2
Satellite Radio and MP3 Audio Servers.....	2
2-Series Ethernet Control System .....	3
Home Automation and Integration.....	3
Applications.....	3
Specifications .....	4
Physical Description.....	8
Industry Compliance .....	16
Setup.....	17
Network Wiring.....	17
Hardware Hookup .....	17
Configuration.....	24
Configure the AES for Operation.....	24
Configure Sources .....	32
Configure Rooms .....	32
Configure Preset Groups .....	36
Operation .....	37
Source Mode.....	37
Controlling a Tuner .....	37
Controlling an iPod .....	51
Controlling an Adagio Audio Server (AAS).....	53
Route a Source .....	58
Room Mode.....	59
Recall a Preset Group .....	62
Turn off the System.....	62
Programming Software.....	63
Earliest Version Software Requirements for the PC .....	63
Programming with Adagio Composer .....	64
Programming with Crestron SystemBuilder.....	64
Programming with SIMPL Windows .....	64
Programming with VisionTools Pro-e.....	65
Switching Programs.....	65
Saving Settings .....	66
Example Program .....	66
Uploading and Upgrading.....	67
Establishing Communication.....	67
Programs and Firmware .....	68
Problem Solving .....	70
Troubleshooting.....	70

Check Network Wiring..... 71  
Reference Documents..... 72  
Further Inquiries ..... 72  
Future Updates ..... 72  
Software License Agreement..... 73  
Return and Warranty Policies ..... 75  
Merchandise Returns / Repair Service ..... 75  
CRESTRON Limited Warranty..... 75

# Entertainment System: Adagio AES

---

## Introduction

### Features and Functions

- Whole-house audio distribution system
- Out-of-the-box functionality (no programming required):
  - ⇒ Audio distribution for six rooms at 45 watts per channel; expandable to 12 rooms when used with Adagio Audio Expander (AAE)
  - ⇒ Control from front panel or any combination of six (up to 12 if used with AAE) APAD LCD controllers or C2N-DBF12 12-button room keypads
  - ⇒ Built-in support for (2) optional ATC tuner cards, (1) Interface for Apple iPod® (CEN-IDOC), (1) AAE and (1) Adagio Audio Server (AAS)
- 45 watts per channel for six rooms, expandable to 24 rooms with additional Adagio Audio Expanders
- Enhanced front panel provides control of whole-house audio
- Room Grouping function allows easy routing of one source to multiple rooms at once
- Control audio functions from the built-in LCD-driven front panel, 12-button room keypads, or APAD LCD controllers. Other control devices can be used with additional programming
- Accepts up to three (optional) tuner cards for XM®<sup>1</sup> Satellite Radio, SIRIUS®<sup>2</sup> Satellite Radio, or AM/FM radio
- Plug-and-play support for Adagio Audio Servers (AAS-1, AAS-2, AAS-4) and Interface for Apple iPod (CEN-IDOC)
- 2-Series Ethernet control system — programmable to support Crestron® touchpanels, wireless remotes, lighting dimmers, thermostats, and more!

1. Hardware and required basic monthly subscription sold separately. Premium Channel available at additional monthly cost. Installation costs and other fees and taxes, including a one-time activation fee may apply. Subscription fee is consumer only. All fees and programming subject to change. Subscriptions subject to Customer Agreement available at [xmradio.com](http://xmradio.com). Only available in the 48 contiguous United States. ©2007 XM Satellite Radio Inc. All rights reserved. All other trademarks are the property of their respective owners.
2. © SIRIUS Satellite Radio Inc. “SIRIUS” and the SIRIUS dog logo are registered trademarks of SIRIUS Satellite Radio Inc.

### ***Multi-Room Audio***

The AES supports up to six sets of stereo room speakers, allowing listeners in each room to listen selectively to any of 10 different stereo sources. Its integrated multi-channel power amplifier delivers a robust 45 watts per channel to all rooms. Without requiring any programming, the AES can easily be expanded to support a total of 12 rooms by adding an AAE Audio Expander. Or, as many as 24 rooms can be handled using three AAEs with simple setup provided by Crestron Adagio Composer software.

### ***High-End Performance***

An advanced Class G amplifier topology produces the great sound of a classic Class AB design with near-digital efficiency. A massive MOH-core toroidal power transformer directs pure, continuous power to each channel, achieving exceptional dynamic range and low distortion sound quality in every room. Gentle power-up is achieved through a "soft-start" inrush current limiting circuit, and quick-response output protection on each channel prevents failure caused by speaker line faults and overheating.

### ***Enhanced Front Panel Control***

With its large backlit LCD display, room and group select buttons, four softkeys and dual rotary encoders, the AES front panel provides a very powerful, yet friendly user interface for controlling audio to a houseful of speakers. Custom naming of rooms, groups, and sources is facilitated on the LCD display, and also on the custom label strip using Crestron Engraver software.

### ***Preset Groups***

The "Group" feature makes it simple to combine speakers in adjacent rooms, or switch into whole-house party mode, by letting the user link any number of rooms to function as one. Grouping lets you easily route one source to multiple rooms at once without the sync problems common to streaming-based systems. Up to six groups can be defined using the front panel preset group buttons.

### ***Versatile Room Controls***

A choice of basic 12-button keypads or the advanced APAD Wall Mount LCD Controller enables versatile control of the AES in every room. A keypad provides the essential controls for adjusting volume, selecting sources, and toggling up and down through tracks and radio channels. For more elegant control, the APAD actually extends the many functions of the AES front panel to each room, providing true feedback for display of audio sources, radio stations, CD titles, artists, and tracks by name, plus audio settings and many other parameters.

### ***Satellite Radio and MP3 Audio Servers***

Up to three dual radio tuner cards can be installed in the AES to enable combinations of up to six AM/FM, XM and SIRIUS Satellite Radio tuners, letting listeners in different rooms each enjoy their own choice of music, news, sports and talk. With satellite's digital signal, plus RDS/RBDS data on the FM signal, the AES enables the display of the full radio station name and other detailed information about the song or program that is selected. The AES comes with one tuner card included.

In addition to radio, ten line-level inputs are provided (Inputs 1-6 are shared with the tuner card slots) to accommodate external audio sources including Crestron's AAS Audio Server and CEN-IDOC Interface for Apple iPod®. Plug-and-play

compatibility with the AAS and CEN-IDOC delivers instant access to an entire collection of music from any room in the house with fully bidirectional communications for browsing by album, artist, and song title.

### 2-Series Ethernet Control System

Adagio brings Crestron's industry-leading Total Home Technology to homes of any size and budget. At the heart of the AES is the 2-Series control engine. With both Cresnet® and Ethernet connectivity, plus custom programmability using Crestron SystemBuilder™ software, the AES allows customization using Crestron's entire line of touchpanels, wireless remotes, and hundreds of other devices. The built-in Web server with native e-Control®2 XPanel support enables full remote control over IP from computers and PDA devices, as well as remote diagnostics and updates. Built-in IR, RS-232, relay and digital input ports are included to interface the AES with non-Crestron devices ranging from CD changers to security systems.

### Home Automation and Integration

More than just an audio distribution system, the AES can actually grow as part of a complete home automation solution supporting all of Crestron's Cresnet and infiNET™ controllable dimmers, shade controllers, thermostats, and so much more.

### Applications

The following diagram shows an AES as the centerpiece of an Adagio system using out-of-the-box functionality.

*AES as the Centerpiece of an Adagio System*

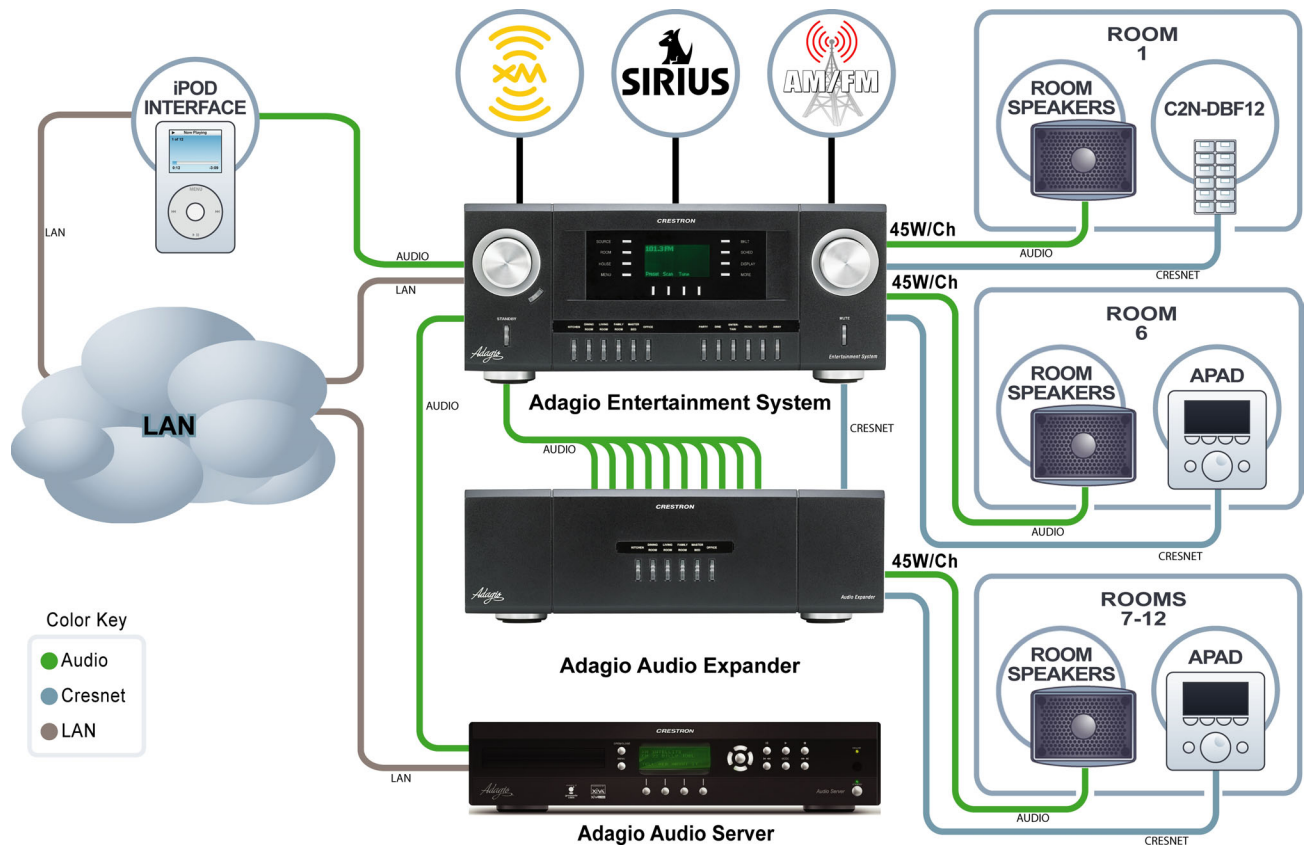

Available models are:

- AES: AES with ATC-AMFM2 Tuner Card
- AES-XM: AES with ATC-AMFMXM Tuner Card
- AES-SR: AES with ATC-AMFMSR Tuner Card (available soon)
- AESI: AES for International (230 VAC) use with ATC-AMFM2 Tuner Card

Out of the box, the AES can support one AAS (Adagio Audio Server), one AAE (Adagio Audio Expander) for control of up to 12 zones, one CEN-IDOC (Interface for Apple iPod®), and a combination of up to 12 C2N-DBF12 (12-button keypads) or APAD controllers for local control of each zone.

With custom programming (via Adagio Composer, Crestron SystemBuilder™, or SIMPL™ Windows®) and additional AAEs, the AES can control up to 24 zones of audio. Additional APADS, C2N-DBF12s, CEN-IDOCs and AAS devices can also be added as well as other Crestron peripherals.

## Specifications

Specifications for the AES are listed in the following table.

### *AES Specifications*

SPECIFICATION	DETAILS
Processor CPU Processing Speed	32-bit Freescale ColdFire® Microprocessor 66 MIPS (Dhrystone 2.1 Benchmark)
Memory	8MB Flash, 32MB SDRAM, 256KB NVRAM
Operating System	Real-time, preemptive, multitasking kernel, multi-threaded, FAT32 file system with long names; supports SIMPL Windows and SIMPL+®
Ethernet	10/100BaseT, static IP or DHCP/DNS, SSL, autonegotiating, full duplex TCP/IP, UDP/IP, SMTP, SNMP, built-in Web server and e-mail client; supports Crestron e-Control®2 XPanel and RoomView® applications
Audio Specifications (Typical of six room outputs)	
Controls	Volume, Balance, Bass, Treble, Loudness, Mute, Mono, Input Compensation
Preamplifier Output	(6) unbalanced line-level audio outputs; Selectable for variable or fixed level;
Frequency Response	20Hz to 20kHz ±0.2dB
Volume Range	-80dB to +20dB, 1dB steps
Bass Range (100Hz)	±12dB @100Hz, 2dB steps
Treble Range (10kHz)	±12dB @10kHz, 2dB steps
Total Harmonic Distortion (THD)	< 0.05%

*(Continued on following page)*



*AES Specifications (Continued)*

SPECIFICATION	DETAILS
Audio Specifications (Continued)	
Signal-to-Noise Ratio (SNR)	> 100dB
Stereo Separation	>80dB
Mute	-100dB (electronic), -120dB (relay)
Maximum Output	2.5 V <sub>rms</sub>
Output Impedance:	100 Ohms
Amplifier Output	
Power	45 Watts into 8 Ohms 60 Watts into 4 Ohms
Frequency Response	20Hz to 20kHz ±0.75dB
Signal-to-Noise Ratio (SNR)	100dB
Total Harmonic Distortion (THD)	0.05%
Stereo Separation	> 75dB
Inputs	
Audio	(10) unbalanced stereo line-level audio inputs with parallel loop-thrus; connect to outputs of sources, with loop-thru to AAE; Inputs 1 through 6 reserved for optional tuner cards (if installed)
Maximum Input	3.2 V <sub>rms</sub> (flat)
Input Impedance	47k Ohms
Input Compensation	±10dB
Tuner Card Slots	(3) Reserved for optional: <ul style="list-style-type: none"> <li>• <b>ATC-AMFM2</b> Adagio Dual AM/FM Tuner Card</li> <li>• <b>ATC-AMFMXM</b> Adagio AM/FM and XM Satellite Radio Tuner Card</li> <li>• <b>ATC-AMFMSR</b> Adagio AM/FM and SIRIUS Satellite Radio Tuner Card</li> </ul>
Infrared	(1) mini-phone jack; For connection of the CNXRMIRD IR detector (sold separately); Allows IR wireless control from third-party universal remotes using RC-5 IR commands
Digital	(4) digital inputs; Rated for 0-24V DC, referenced to GND;
Input Impedance	2.2k ohms pulled up to 5V DC
Logic Threshold	2.5V DC nominal
Outputs	
Infrared/Serial	(8) mini-phone jack, IR/Serial port;
IR output	Up to 1.2 MHz

*(Continued on following page)*

*AES Specifications (Continued)*

SPECIFICATION	DETAILS
Outputs (continued) Serial output	One-way serial TTL/RS-232 (0-5V) up to 9600 baud
Relay Rating	(4) Normally open, isolated relays; 1A, 30V AC/DC; MOV arc suppression across contacts
Communication Cresnet®	(6) Cresnet Master ports, provide data and power for C2N-DBF12 keypads and APAD devices  (2) Cresnet Master ports, paralleled with six Cresnet ports previously described, provide data to connected Adagio Audio Expanders (AAE)
Serial	(2) DB9, male, bidirectional RS-232 ports; Up to 115.2k baud, hardware and software handshaking support for communication with serial devices
Console	(1) RJ-11 female, bidirectional RS-232 computer console port for connection to PC (1) USB 1.1 (Type B female) computer console port for connection to PC
Ethernet	(1) RJ-45 port for Ethernet communications
Power Internal Power Supply AES/AES-XM/AES-SR AESI Available Cresnet Power Heat Dissipation* 8-ohm impedance 4-ohm impedance	7 Amps, 120 Volts AC @ 60Hz 3.5 Amps, 230 Volts AC @ 50Hz 20 Watts (0.83 Amps @ 24 Volts DC)  650 BTU/hr 750 BTU/hr
LCD Display	Green LCD dot matrix, 128 x 64 resolution, adjustable LED backlight
Environmental Temperature Humidity	41° to 104°F (5° to 40°C) 10% to 90% RH (non-condensing)
Enclosure	Black metal with molded ABS/PC front panel
Dimensions Height Width Depth	7.39 in (18.78 cm) 17.16 in (43.58 cm) 18.60 in (47.24 cm)
Weight	43 lb (19.5 kg)

\* BTU/hr ratings made while all channels loaded to 1/8 full power with specified impedance.

*(Continued on following page)*

*AES Specifications (Continued)*

SPECIFICATION	DETAILS
Available Models AES AES-XM AES-SR AESI	AES with ATC-AMFM2 Dual AM/FM Tuner Card AES with ATC-AMFMXM AM/FM and XM Satellite Radio Tuner Card AES with ATC-AMFMSR AM/FM and SIRIUS Satellite Radio Tuner Card AES for International (230 VAC) use with ATC-AMFM2 Dual AM/FM Tuner Card
Available Accessories: APAD ATC-AMFM2 ATC-AMFMXM ATC-AMFMSR AAE AAS CEN-IDOC C2N-DBF12 CNXRMIRD STIRP CNSP-XX C2N-TXM-C50	Wall Mount LCD Controller Adagio Dual AM/FM Tuner Card Adagio AM/FM and XM Satellite Radio Tuner Card Adagio AM/FM and SIRIUS® Satellite Radio Tuner Card Adagio Audio Expander Adagio Audio Server Interface for Apple iPod® 12-Button Decorator Keypad IR Receiver IR Probe Custom Serial Interface Cable XM Antenna Extension Cable

### Physical Description

This section provides information on the connections, controls, and indicators available on your AES.

*AES Physical View (Front)*



*AES Physical View (Rear), Shown with ATC-AMFM2 Adagio AM/FM Dual Tuner Card and ATC-AMFMXM Adagio AM/FM and XM Satellite Radio Tuner Card*



*AES Overall Dimensions*

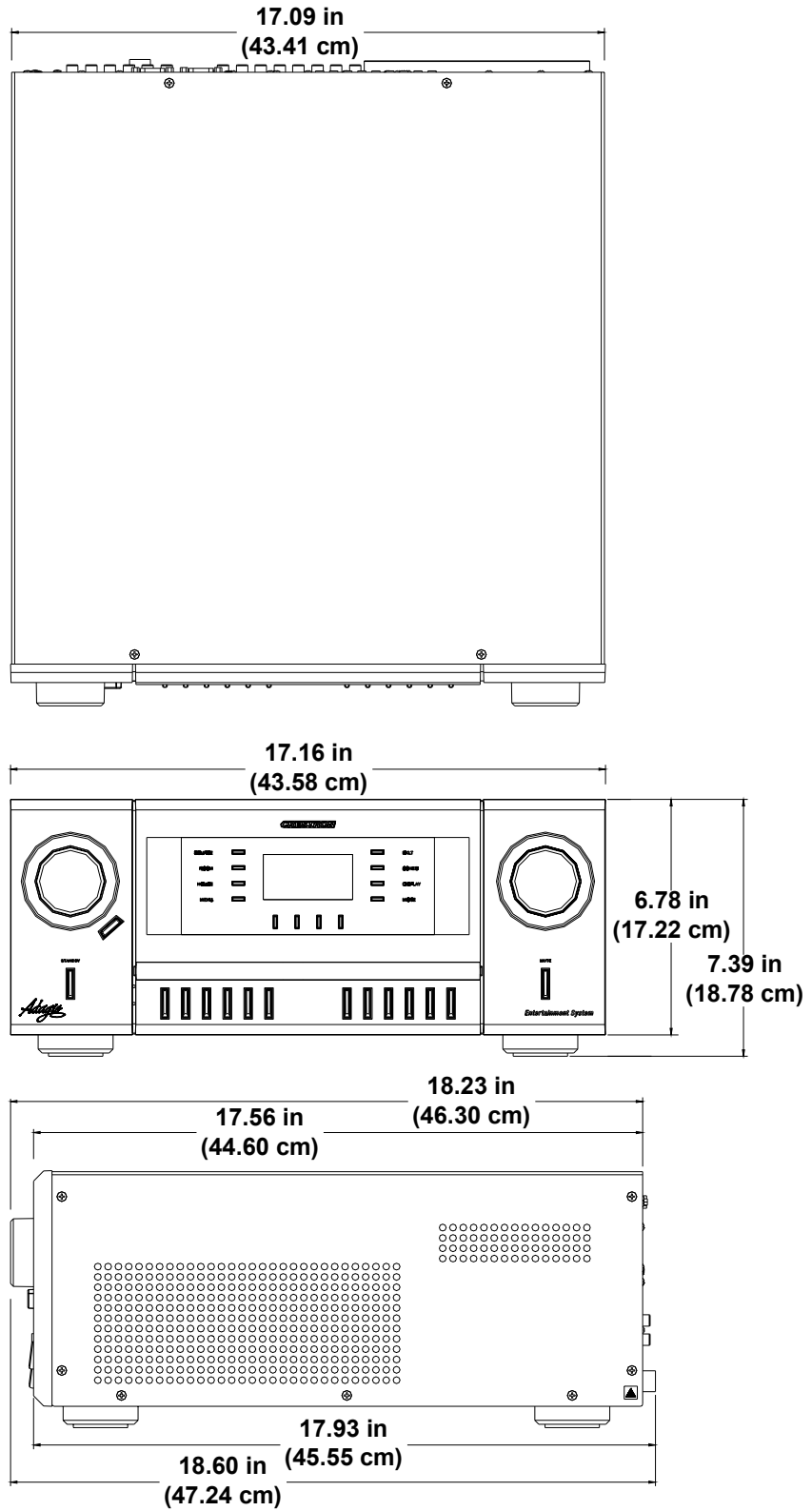

**NOTE:** Cable connections can extend the overall depth of the AES by approximately two to three inches.

AES Buttons and Ports

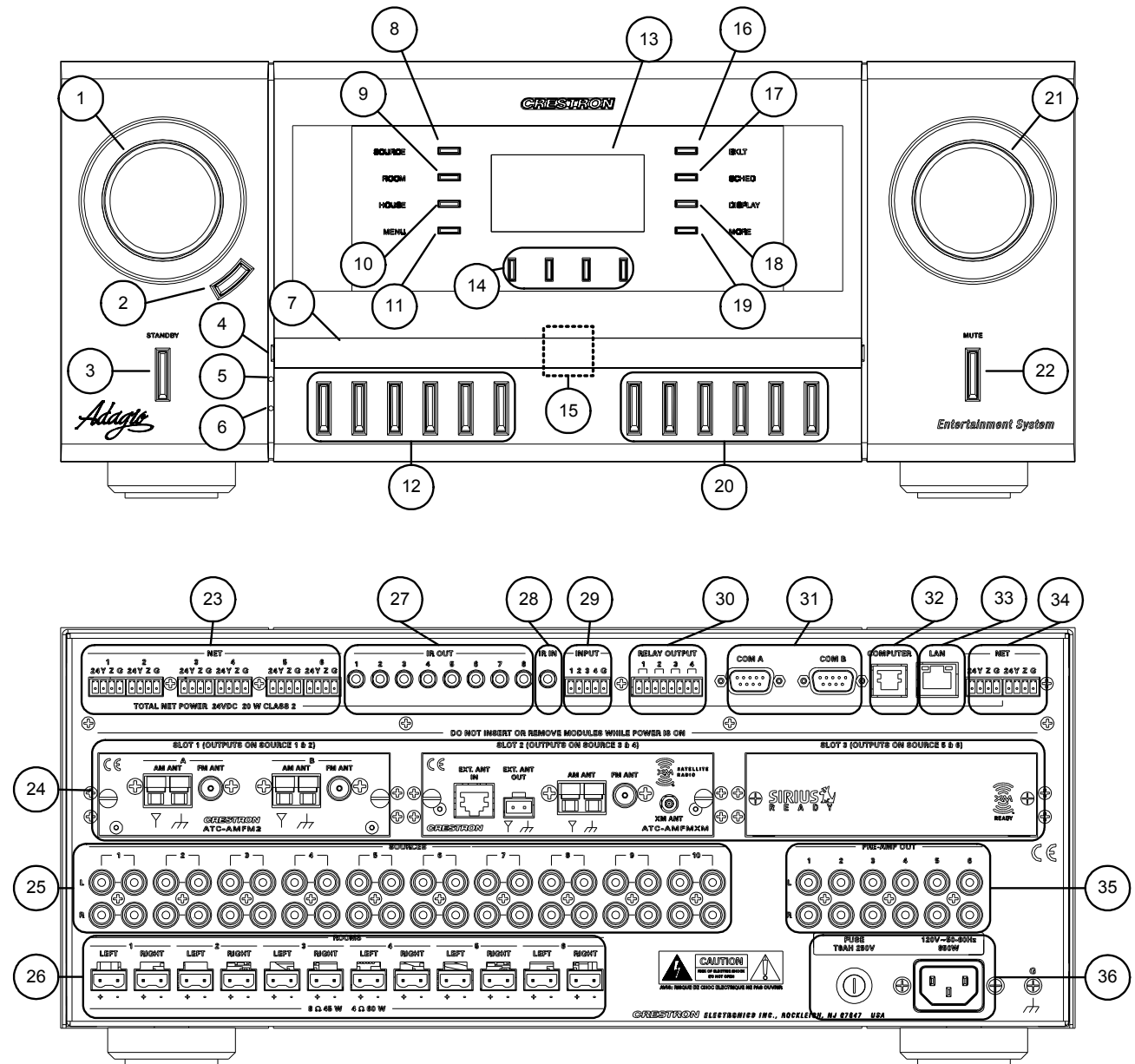



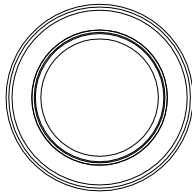





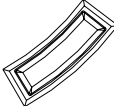

Connectors, Controls, & Indicators

#	CONNECTORS, CONTROLS, & INDICATORS	DESCRIPTION
1		Used to select rooms, sources, and radio stations (when using tuner).











(Continued on following page)

*Connectors, Controls, & Indicators (Continued)*

#	CONNECTORS, CONTROLS, & INDICATORS	DESCRIPTION
2	<p>ENTER BUTTON</p> 	The ENTER button confirms changes made to AES settings.
3	<p>STANDBY BUTTON</p> <p>STANDBY</p> 	The STANDBY button places the unit in <i>Standby</i> . The button is lit when the AES is in use. When in <i>Standby</i> , the button will not be lit, all switching connections are broken, and all of the amplifier and pre-amplifier outputs are powered off. Turning on a room turns on the AES.
4	LABEL ACCESS	A notch in the front panel allows removal of the label cover (and access to the USB port, # 15) with a flat-head screwdriver.
5	<p>HARDWARE RESET</p> 	Recessed below the front panel. Press this button to initiate a system hardware reset. This has the same effect as disconnecting and reconnecting power.
6	<p>SOFTWARE RESET</p> 	Recessed below the front panel. Press this button while the system is running to restart the program without rebooting the processor. Hold during reboot to bypass the custom program and run the built-in out-of-the-box functionality.
7	LABEL STRIP COVER	Covers the engraved label strip and the USB port (#15).
8	<p>SOURCE BUTTON</p> <p>SOURCE</p> 	The SOURCE button places the AES in the <i>Source</i> mode.
9	<p>ROOM BUTTON</p> <p>ROOM</p> 	The ROOM button places the AES in the <i>Room</i> mode.
10	<p>HOUSE BUTTON</p> <p>HOUSE</p> 	Functions controlled by the HOUSE button are determined in a custom program created by SystemBuilder.
11	<p>MENU BUTTON</p> <p>MENU</p> 	The MENU button returns the display (#13) to the previous screen.
12	<p>ROOM BUTTONS</p> 	Room buttons select and indicate the room(s) controlled by the AES. Room buttons also indicate rooms contained in a room group.
13	LIQUID CRYSTAL DISPLAY	The Liquid Crystal Display (LCD) shows system information such as audio controls, tuner controls, and room controls.
14	<p>SOFT BUTTONS</p> 	Function of soft buttons are dependent on operation of AES.

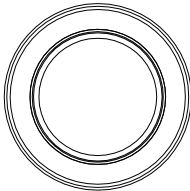
*(Continued on following page)*

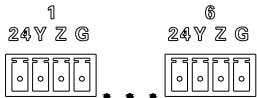





Connectors, Controls, & Indicators (Continued)

#	CONNECTORS, CONTROLS, & INDICATORS	DESCRIPTION
15	<p>USB PORT</p> 	Hidden behind the label cover is a USB port for PC communications. Requires a standard PC-to-USB-device cable (included).
16	<p>BKLT</p> 	The BKLT button adjusts the display and key backlighting to one of 3 levels (high, medium, low).
17	<p>SCHED</p> 	The SCHED button places the AES in the <i>Schedule</i> mode which is programmed in SystemBuilder.
18	<p>DISPLAY</p> 	The DISPLAY button toggles the information shown on the display (i.e. artist and/or song title).
19	<p>MORE</p> 	The MORE button displays additional controls for the SOFT BUTTONS (if available).
20	<p>PRESET GROUP BUTTONS</p> 	Used to select preset groups.
21	<p>VOLUME CONTROL KNOB</p> 	Turn clockwise to raise the volume of a room; turn counterclockwise to lower the volume of a room. Turning the volume control slowly will adjust the volume level in fine increments while turning the volume control quickly will adjust the volume level in larger increments. Volume level is displayed on the LCD. Operates in <i>Room</i> mode only.
22	<p>MUTE BUTTON</p> 	The MUTE button is used to mute or unmute the currently selected room. When lit, the selected room is muted.
23	<p>NET 1-6</p> 	(6) Four-pin terminal blocks provide home run Cresnet® connections to distribute power and Cresnet data to rooms for keypads and/or APADs. Four-pin terminal block interface connectors are included for each port.
24	<p>CARD SLOTS 1-3 (SLOT 1 SHOWN WITH ATC-AMFM2 INSTALLED)</p> 	(3) Slots for optional ATC-AMFM2, ATC-AMFMXM, and ATC-AMFMSR tuner cards. A card installed in slot 1 will drive source input ports 1 and 2. A card installed in slot 2 will drive source input ports 3 and 4. A card installed in slot 3 will drive source input ports 5 and 6. Any input sources driven by a tuner card cannot be connected to other input devices.

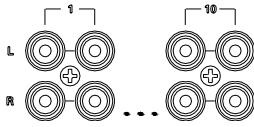
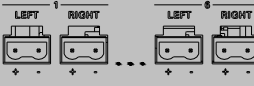
(Continued on following page)

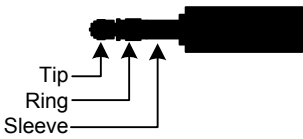

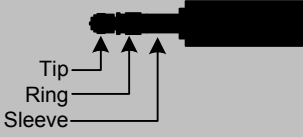

Connectors, Controls, & Indicators (Continued)

#	CONNECTORS, CONTROLS, & INDICATORS	DESCRIPTION
25	<p style="text-align: center;">SOURCES</p> 	<p>(10) Sets of unbalanced, line-level audio inputs with loop through output. Inputs 1 through 6 are driven by tuner cards installed in slots 1 through 3 (#24) and cannot be used by external sources when tuner cards are installed. Refer to “Adagio Tuner Cards” on page 20 for information on which input ports are reserved for which card slot.</p>
26	<p style="text-align: center;">ROOMS</p> 	<p>(6) Sets of speaker-level, mono/stereo outputs provide 45 watts per channel into 8-ohm impedance speakers (60 watts into 4-ohm impedance speakers). Two-pin terminal block interface connectors which accept up to 12 AWG (4.0 mm<sup>2</sup>) speaker wire are included for each speaker terminal.</p>
27	<p style="text-align: center;">IR OUT</p> <p style="text-align: center;">IR OUT</p> 	<p>(8) 3.5 mm tip-ring-sleeve (TRS) mini-phone ports enable serial communication in a variety of formats including infrared and one-way RS-232; Use Crestron Infrared Emitter Probe (part number STIRP, sold separately) for controlling infrared devices. For information on other serial control cables, contact Crestron.</p>  <p>Tip: IR Data Out Ring: No Connection Sleeve: Ground</p>
28	<p style="text-align: center;">IR IN</p> <p style="text-align: center;">IR IN</p> 	<p>(1) 3.5 mm TRS mini-phone port allows IR wireless control from third-party universal remotes (via Crestron IR Receiver CNXRMIRD) using RC-5 IR commands.</p>  <p>Tip: IR Data In Ring: +5 VDC Sleeve: Ground</p>
29	<p style="text-align: center;">INPUT</p> <p style="text-align: center;">— INPUT —</p> 	<p>(4) Digital inputs. Connect to 24 VDC (max) logic output or contact closure from external devices. A five-pin terminal block interface connector is included.</p>

(Continued on following page)

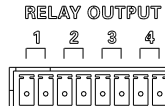
Connectors, Controls, & Indicators (Continued)

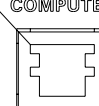
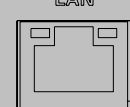
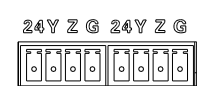
#	CONNECTORS, CONTROLS, & INDICATORS	DESCRIPTION																														
30	<p>RELAY OUTPUT</p> 	<p>(4) Normally open isolated relays; rated to 1A, 30V (AC/DC) with MOV arc suppression across contacts for control of “real world” loads. An eight-pin terminal block interface connector is included.</p>																														
31	<p>COM A &amp; COM B</p> 	<p>(2) DB9, male, bidirectional RS-232 ports; Up to 115.2k baud with hardware and software handshaking support for communication with serial devices. Can also be used for modem communications. The following table lists the pin assignments of the serial ports.</p> <table border="1"> <thead> <tr> <th>PIN</th> <th>DIRECTION</th> <th>DESCRIPTION</th> </tr> </thead> <tbody> <tr> <td>1</td> <td>To AES</td> <td>(DCD) Data Carrier Detect</td> </tr> <tr> <td>2</td> <td>To AES</td> <td>(RXD) Receive Data</td> </tr> <tr> <td>3</td> <td>From AES</td> <td>(TXD) Transmit Data</td> </tr> <tr> <td>4</td> <td>From AES</td> <td>(DTR) Data Terminal Ready</td> </tr> <tr> <td>5</td> <td>Common</td> <td>(GND) Ground</td> </tr> <tr> <td>6</td> <td>To AES</td> <td>(DSR) Data Set Ready</td> </tr> <tr> <td>7</td> <td>From AES</td> <td>(RTS) Request To Send</td> </tr> <tr> <td>8</td> <td>To AES</td> <td>(CTS) Clear To Send</td> </tr> <tr> <td>9</td> <td>To AES</td> <td>(RI) Ring Indicator</td> </tr> </tbody> </table>	PIN	DIRECTION	DESCRIPTION	1	To AES	(DCD) Data Carrier Detect	2	To AES	(RXD) Receive Data	3	From AES	(TXD) Transmit Data	4	From AES	(DTR) Data Terminal Ready	5	Common	(GND) Ground	6	To AES	(DSR) Data Set Ready	7	From AES	(RTS) Request To Send	8	To AES	(CTS) Clear To Send	9	To AES	(RI) Ring Indicator
PIN	DIRECTION	DESCRIPTION																														
1	To AES	(DCD) Data Carrier Detect																														
2	To AES	(RXD) Receive Data																														
3	From AES	(TXD) Transmit Data																														
4	From AES	(DTR) Data Terminal Ready																														
5	Common	(GND) Ground																														
6	To AES	(DSR) Data Set Ready																														
7	From AES	(RTS) Request To Send																														
8	To AES	(CTS) Clear To Send																														
9	To AES	(RI) Ring Indicator																														
32	<p>COMPUTER</p> <p>PIN 1 — COMPUTER</p> 	<p>One 6-pin RJ-11 female, computer console port. Use with included serial cable.</p> <p>Pin 1: CTS Pin 2: GND Pin 3: RXD Pin 4: TXD Pin 5: RTS Pin 6: N/C (Not connected)</p>																														
33	<p>LAN</p> 	<p>One 8-wire, RJ-45 female connector with two LED indicators. The green LED indicates link status while the yellow LED indicates Ethernet activity. The port supports 10BaseT/100BaseTX Ethernet communications.</p>																														
34	<p>NET</p> 	<p>(2) Four-pin terminal block connectors provide Cresnet connections to AAE devices. A four-pin terminal block interface connector is included for each port.</p>																														

(Continued on following page)

Connectors, Controls, & Indicators (Continued)

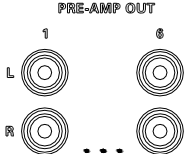
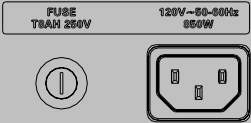
#	CONNECTORS, CONTROLS, & INDICATORS	DESCRIPTION
35	<p>PRE-AMP OUT</p> 	<p>(6) Unbalanced, line-level audio output ports associated with each room (RCA connector). Each port has selectable electronic volume, tone, balance and loudness control.</p>
36	<p>POWER INPUT</p> 	<p>Fuse terminal and power connector.</p> <p>The AES requires a T8AH-type fuse rated at 250 Volts<sup>1</sup>. The AES requires 120 VAC, 50-60 Hz, 7 Amps.</p> <p>The AESI requires a T4AH-type fuse rated at 250 Volts<sup>1</sup>. The AESI requires 230 VAC, 50-60 Hz, 3.5 Amps<sup>2</sup>.</p>

1. Refer to “Fuse Replacement” on page 21 for additional details.
2. Refer to “Hardware Hookup”, which begins on page 17 for additional cord details.

## Industry Compliance

This product is Listed to applicable UL Standards and requirements by Underwriters Laboratories Inc.

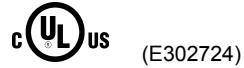

As of the date of manufacture, the AES has been tested and found to comply with specifications for CE marking and standards per EMC and Radiocommunications Compliance Labelling.



---

**NOTE:** This device complies with part 15 of the FCC rules. Operation is subject to the following two conditions: (1) this device may not cause harmful interference, and (2) this device must accept any interference received, including interference that may cause undesired operation.

This equipment has been tested and found to comply with the limits for a Class B digital device, pursuant to part 15 of the FCC Rules. These limits are designed to provide reasonable protection against harmful interference in a residential installation. This equipment generates, uses and can radiate radio frequency energy and, if not installed and used in accordance with the instructions, may cause harmful interference to radio communications. However, there is no guarantee that interference will not occur in a particular installation. If this equipment does cause harmful interference to radio or television reception, which can be determined by turning the equipment off and on, the user is encouraged to try to correct the interference by one or more of the following measures:

- Reorient or relocate the receiving antenna.
  - Increase the separation between the equipment and receiver.
  - Connect the equipment into an outlet on a circuit different from that to which the receiver is connected.
  - Consult the dealer or an experienced radio/TV technician for help.
-

---

## Setup

### Network Wiring

When wiring the AAE Adagio Audio Expander, APAD controller, or C2N-DBF12 keypad to the AES, consider the following:

- Use Crestron Certified Wire.
- Use Crestron power supplies for Crestron equipment.
- Provide sufficient power to the system.

---

**CAUTION:** Insufficient power can lead to unpredictable results or damage to the equipment. Please use the Crestron Power Calculator to help calculate how much power is needed for the system

(<http://www.crestron.com/calculators>).

---

- For larger networks, Use a Cresnet Hub/Repeater (CNXHUB) to maintain signal quality

For more details, refer to “Check Network Wiring” on page 71.

### Hardware Hookup

#### Ventilation

The AES should be used in a well-ventilated area. Do not block any ventilation openings. The venting holes should not be obstructed under any circumstances. If the AES is hot to the touch, consider using forced air ventilation and/or incrementing the spacing between units.

To prevent overheating, do not operate this product in an area that exceeds the environmental temperature range listed in the table of specifications. Consideration must be given if installed in a closed or multi-unit rack assembly since the operating ambient temperature of the rack environment may be greater than the room ambient. Contact with thermal insulating materials should be avoided on all sides of the unit.

#### Out-of-the-box Connections

---

**WARNING:** To prevent injury and / or equipment damage due to electric shock, disconnect power from the AES prior to making any wiring connections.

---

When using the out-of-the-box functionality, the AES can support up to two tuner cards, one AAE, one CEN-IDOC, one AAS-1/-2/-4, and any combination of six APAD or C2N-DBF12 control devices (plus an additional six on the AAE if connected). Observe the following when connecting hardware to the AES.

- Tuner Cards (Optional): Tuner cards must be installed in slots 1 and 2. In the out-of-the-box configuration, a card cannot be installed in slot 3. Source input ports 1 and 2 are unavailable for other sources when a tuner card is installed in slot 1. Source input ports 3 and 4 are unavailable for other sources when a tuner card is installed in slot 2. For information on connecting antennas to a tuner card, refer to the respective tuner card’s guide.

---

**NOTE:** If the AES is powered down and the tuner card(s) are changed, the previously saved source names will be assigned to the new card when the

AES is powered. For example, if an ATC-AMFMXM card has been replaced with an ATC-AMFMSR card, the AES will retain the source names (i.e. AM, FM, XM, or custom) that were assigned to the ATC-AMFMXM card. To have the AES recognize the new cards and use the default source names (S1 AM/FM, S1 XM, etc.), restore the default settings as described on page 31.

---

- CEN-IDOC (Optional): The audio output of the CEN-IDOC must be connected to source input port 5 on the AES when using the out-of-the-box configuration. The CEN-IDOC and AES must be connected to the same DHCP router.
- AAS Devices (Optional): Source input ports 7 through 10 are reserved for the different variations of the AAS. The AAS and AES must be connected to the same DHCP router.
  - ⇒ AAS-1: The audio output of the AAS-1 must be connected to source input port 7.
  - ⇒ AAS-2: Audio output A of the AAS-2 must be connected to source input port 7 and audio output B must be connected to source input port 8.
  - ⇒ AAS-4: Audio output A of the AAS-4 must be connected to source input port 7. Audio output B must be connected to source input port 8. Audio output C must be connected to source input port 9, and audio output D must be connected to source input port 10.
- Control Devices (Optional): Any combination of six APADs or C2N-DBF12 devices can be connected to any of the six NET ports on the rear of the AES. If an AAE is connected, six more APADs or C2N-DBF12 devices can be connected.
- AAE (Optional): One AAE can be connected to the AES' loop-through ports.

---

**NOTE:** The AAE must be set to its default Net ID value (31). For information on setting the AAE's Net ID, refer to the latest version of the AAE guide (Doc. 6460) which is available from the Crestron website.

---

The connections shown in the following diagram must be made for the AES to properly control and switch connected devices when using the out-of-the-box functionality.

---

**CAUTION:** Speakers must be rated to full available output.

**CAUTION:** Do not bridge speaker outputs.

**CAUTION:** All tuner cards should be securely installed in the AES.

**CAUTION:** Devices such as the AAS and the AAE must be fully grounded to the AES. Additionally, any other source devices should be grounded to the AES as well.

**NOTE:** The AES can only be powered by the included power cord. Power cannot be supplied from network devices that are connected to the mini-terminal block connectors.

---

**NOTE:** The AESI (International version) requires a power cord that is harmonized to the country's national and local electrical code. Each inner wire in the cord should be at least 16 AWG or (1.5 mm<sup>2</sup>) and rated for at least 500V. The temperature rating of the cord should be at least 60°C. The cord length should be 1.5 meters to 2 meters.

*Hardware Connections for Out-of-the-Box Functionality (Shown with Tuner Cards in Slots 1 & 2)*

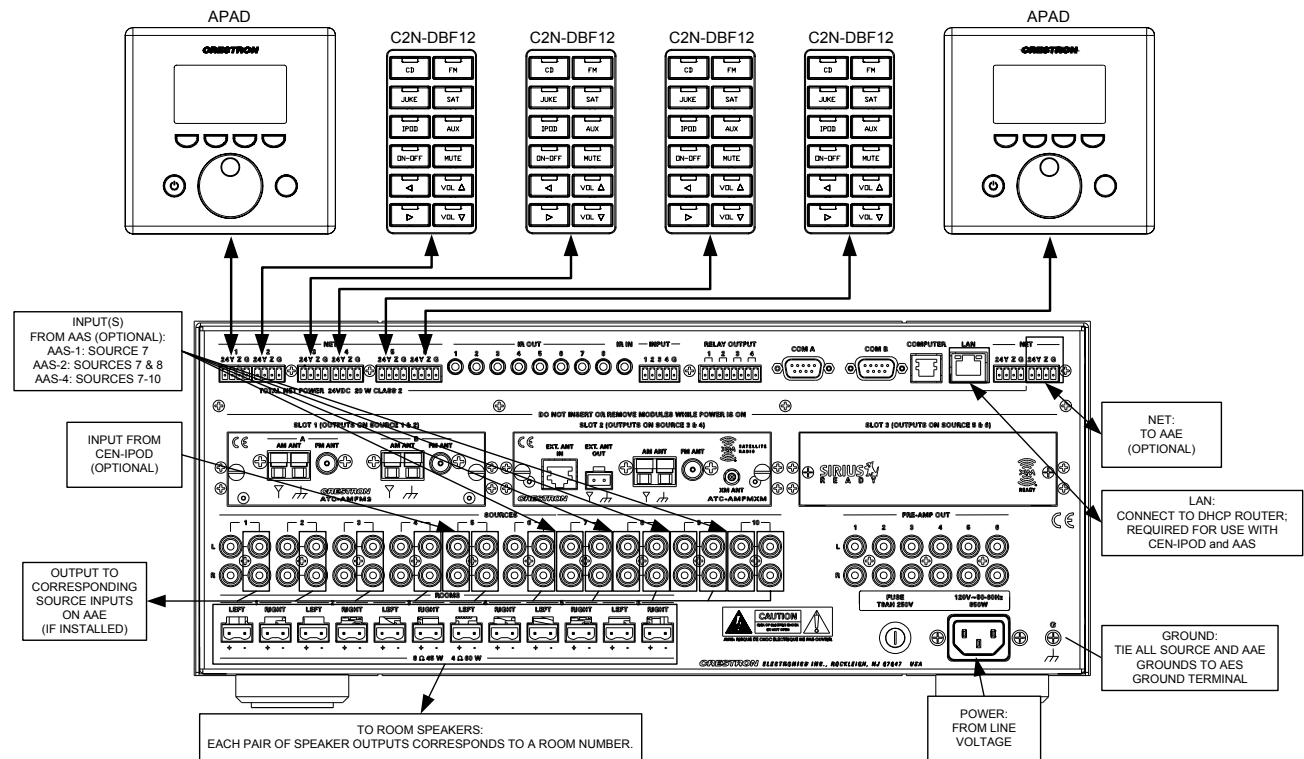

**Custom Program Connections**

Refer to the following when not using the out-of-the-box functionality:

**WARNING:** To prevent injury and / or equipment damage due to electric shock, disconnect power from the AES prior to making any wiring connections.

Make the necessary connections as called out in the illustration that follows this paragraph. Refer to “Network Wiring” on page 17 before attaching the 4-position terminal block connectors. Apply power after all connections have been made.

**CAUTION:** Speakers must be rated to full available output.

**CAUTION:** Do not bridge speaker outputs.

**CAUTION:** All tuner cards should be securely installed in the AES.

**CAUTION:** Devices such as the AAS and the AAE must be fully grounded to the AES. Additionally, any other source devices should be grounded to the AES as well.

**NOTE:** The AES can only be powered by the included power cord. Power cannot be supplied from network devices that are connected to the mini-terminal block connectors.

**NOTE:** The AESI (International version) requires a power cord that is harmonized to the country's national and local electrical code. Each inner wire in the cord should be at least 16 AWG (or 1.5 mm<sup>2</sup>) and rated for at least 500V. The temperature rating of the cord should be at least 60°C. The cord length should be 1.5 meters to 2 meters.

**Custom Program Connections for the AES (Shown with Tuner Cards in Slots 1 & 2)**

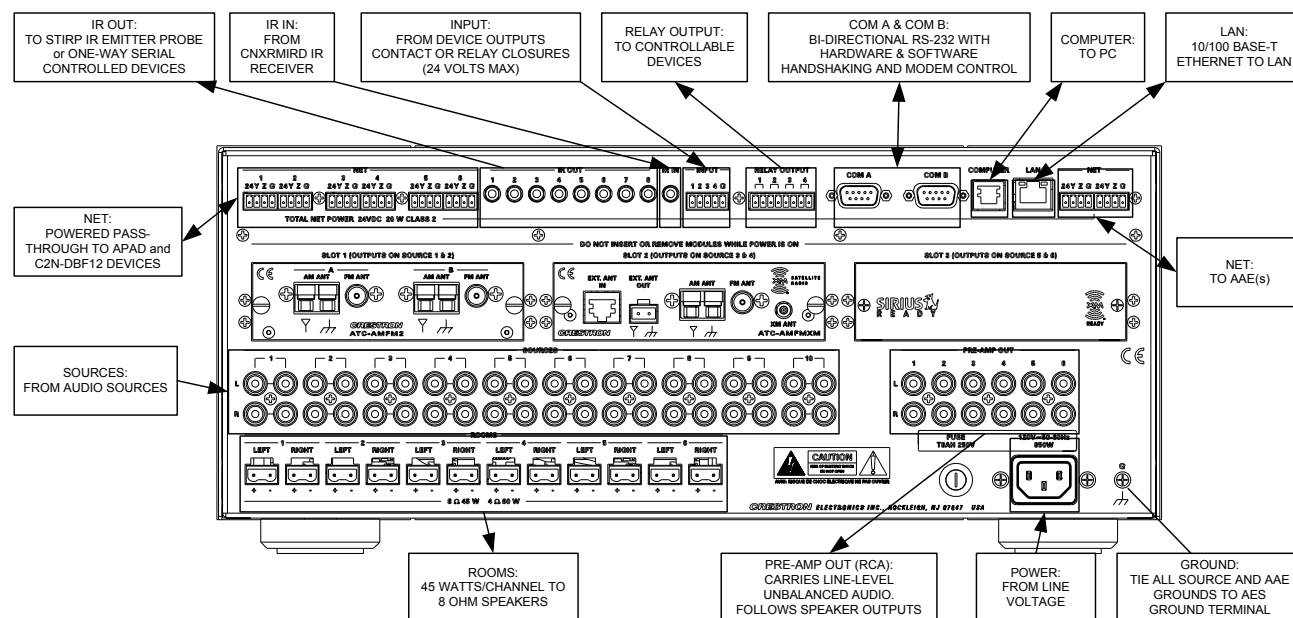

**NOTE:** A USB port is concealed behind the label cover on the front panel. The USB port is used to connect with a PC and provides a console connection to the AES.

**Adagio Tuner Cards**

If optional Adagio tuner cards are installed, refer to the latest version of the respective tuner card's Installation Guide for information on connecting the required antenna(s).

**WARNING:** Tuner cards must not be installed or removed when the AES is connected to AC power. Failure to disconnect AC power prior to installing or removing tuning cards may damage the AES or the tuner card(s).

**NOTE:** If using the AES' out-of-the-box functionality, only two tuner cards can be installed. The tuner cards must be installed in slots 1 and 2.

Source input ports 1 and 2 are unavailable for other sources when a tuner card is installed in slot 1. Source input ports 3 and 4 are unavailable for other sources when a tuner card is installed in slot 2. Source input ports 5 and 6 are unavailable for other sources when a tuner card is installed in slot 3.

When tuner cards are installed in an AES that is connected to an AAE, loop-through output ports 1 through 6 on the AES are connected to source input ports 1 through 6 on the AAE.



**AES Control Devices**

Any combination of six AES control devices such as the APAD or the C2N-DBF12 can be simultaneously connected to the powered NET ports located on the upper-left side of the rear panel. Refer to the following diagram and “Network Wiring” on page 17 for wiring information when connecting either APAD devices or C2N-DBF12 keypads.

**AES with Control Devices**

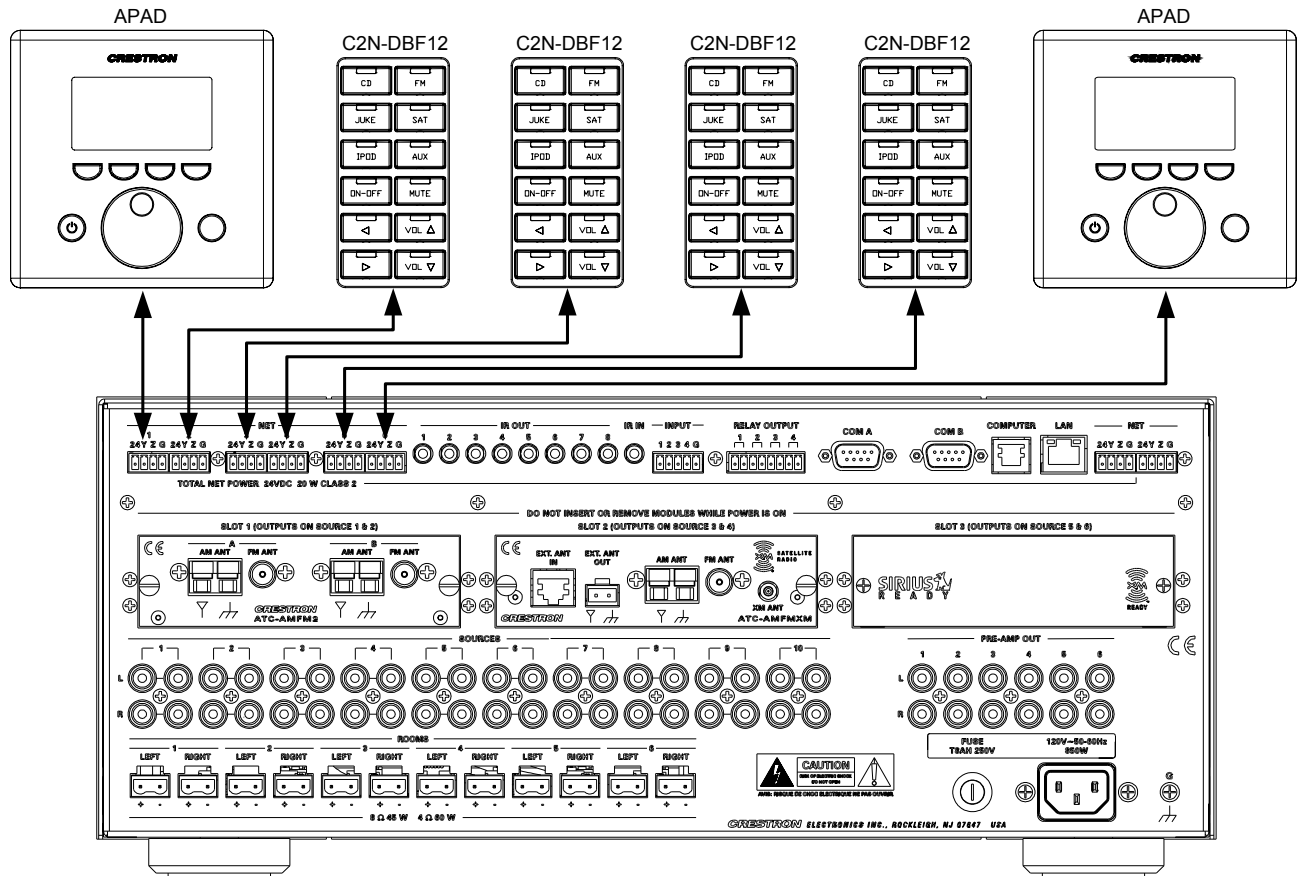

**Fuse Replacement**

If the AES does not power up when it is plugged into an AC outlet, the fuse may need to be replaced. The fuse holder is located on bottom-right of the rear panel (next to the power cord connector). To replace the fuse:

- Press **STANDBY** to place the unit in *Standby*.
- Disconnect power to the AES.
- Use a flat-head screwdriver to push in the fuse holder.
- While pushing in the fuse holder, turn screwdriver counterclockwise until the fuse holder pops out.
- Remove the fuse from the fuse holder and insert a new fuse.

**CAUTION:** Only use the specified type of fuse when replacing a blown fuse. Failure to do so may cause damage to the AES.

AES MODEL	REQUIRED FUSE TYPE
AES (US & Canada)	T8AH (¼" x 1¼", 250V, 8A, time-lag, high-rupture rated)
AESI (International/230VAC)	T4AH (5mm x 20mm, 250V, 4A, time-lag, high-rupture rated)

- Insert the fuse holder into the AES.
- Push in the fuse holder with a flat head screwdriver. While pushing in the fuse holder, turn the screwdriver clockwise until the fuse holder sinks in.
- Push in the fuse holder a little further and turn the screwdriver clockwise until the fuse holder locks in place.
- Connect power to the AES.

### Room & Preset Group Button Labels

Use Adagio Composer or Crestron Engraver software to create and print custom labels on overhead transparency film for the AES' room buttons and preset group buttons.

**NOTE:** When printing custom labels, some experimentation may be required for optimum results.

Custom-engraved labels can also be ordered from Crestron. Contact Crestron for more information.

To remove the label:

1. Remove the label cover with a small, flat-head screwdriver. The label cover is magnetically attached to the front panel of the Adagio component. The label strip will be exposed.
2. Insert the screwdriver behind the label strip as shown in the diagram below.



3. Continue sliding the screwdriver behind the label strip until the top of the label strip slides out as shown below.



4. Continue sliding the screwdriver until the entire top of the label strip is visible. Remove the label strip by pulling the top of the label strip up from the Adagio component as shown in the following picture.

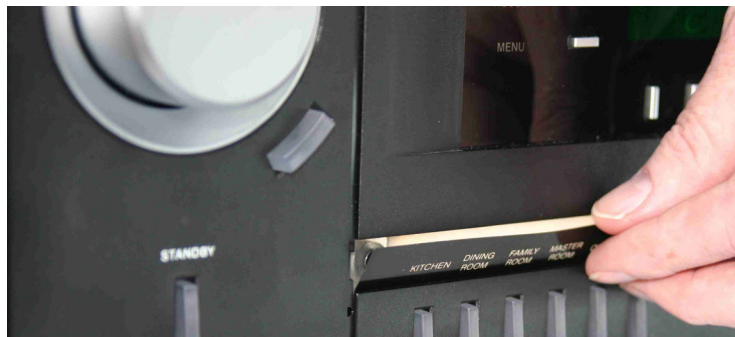

To install the new label:

- Engraved Label Cover: Place the engraved label cover over the label area of the Adagio component until the label cover's integrated magnets snap the label cover into place.
- Printed Label: Place the bottom of the label strip into the Adagio component. Bend the label strip and position the top of the label strip into the Adagio component. Replace the label cover over the new label strip.

---

**NOTE:** Observe proper orientation so the letters are right-side up.

---

## Configuration

After making all hardware connections to the AES, the system must be configured for operation.

Configuring the system is broken down into four processes:

- Configure the AES for Operation
- Configure Sources
- Configure Rooms
- Configure Preset Groups

### Configure the AES for Operation

The AES must be configured for operation prior to configuring sources, rooms, or groups. Use the Installer Tools to configure the AES for operation.

**NOTE:** If a custom program was created with Adagio Composer or SystemBuilder, the following is not required.

#### Open Installer Tools

- Press and hold the **ROOM** and **SOURCE** buttons for 10 seconds to open the Installer Tools menu.

#### Installer Tools Menu

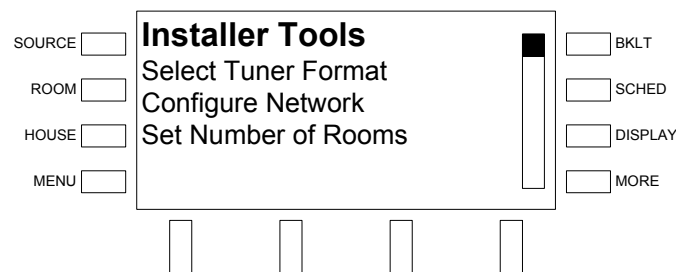

- Scroll through the list of available options using the selection knob. The selected option will be underlined. Available options are:
  - ⇒ Select Tuner Format – Specifies the North American or European tuning format when using a tuner card.
  - ⇒ Configure Network – Configures the AES to communicate with devices that are connected to the AES over Ethernet.
  - ⇒ Set Number of Rooms – Sets the number of rooms to be controlled by the AES.
  - ⇒ Name Rooms – Allows custom naming of rooms controlled by the AES.
  - ⇒ Name Sources – Allows custom naming of audio sources connected to the AES.
  - ⇒ Hide Sources – Allows sources to be removed from the source list.
  - ⇒ Identify Keypads – Registers APAD devices and C2N-DBF12 keypads that are connected to the system.

- ⇒ Load APADs – Programs all connected APAD devices to work with the AES.
- ⇒ Configure Keypads – Configures the source assignments of the top six buttons of every C2N-DBF12 keypad that is connected to the system.
- ⇒ Restore Defaults – Restores default settings.
- ⇒ About – Provides information about the AES such as IP data, firmware version, and program information.

To configure the selected option, press the **ENTER** button.

To exit Installer Tools and save changes to the AES' configuration, press the **MENU** button.

**Select Tuner Format**

Select the tuning format to specify the tuning method used by an installed AM/FM tuner. When using the North American tuner format, the tuner will tune FM frequencies in 100 kHz steps and AM frequencies in 10 kHz steps. When using the European tuner format, the tuner will tune FM frequencies in 50 kHz steps and AM frequencies in 9 kHz steps.

- Open Installer Tools as described on page 24, select **Select Tuner Format**, and press the **ENTER** button

*Select Tuner Format Menu*

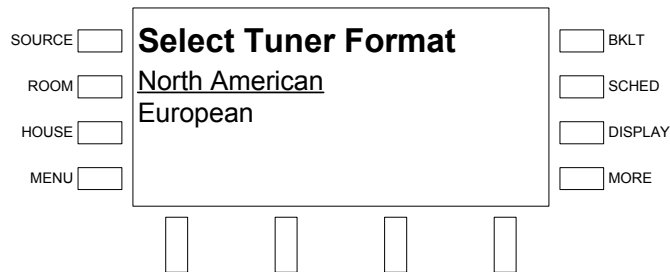

- Use the selection knob to select a tuner format. To cancel and return to the Installer Tools menu, press the **MENU** button.
- To confirm, press the **ENTER** button and return to the Installer Tools menu.

**Configure the Network**

The AES must be configured to recognize devices that communicate over Ethernet (i.e. AAS, CEN-IDOC).

- Open Installer Tools as described on page 24, select **Configure Network**, and press the **ENTER** button.

*Configure Network*

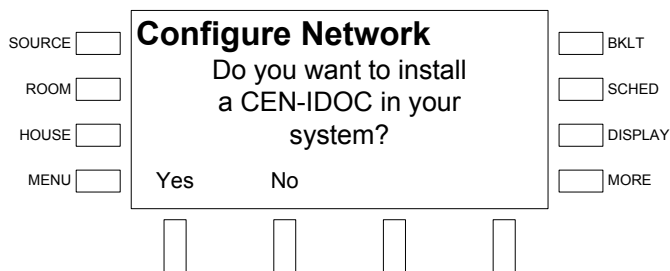

- To install a CEN-IDOC, press the soft button labeled **Yes** and follow the instructions onscreen. Otherwise, press the soft button labeled **No**. The name of the CEN-IDOC will be used in place of “Source 5” in the list of sources.
- To install an AAS, press the soft button labeled **Yes** and follow the instructions onscreen. Otherwise, press the soft button labeled **No**. The source names will be renamed as follows:
  - ⇒ Source 7 becomes “Server 1”<sup>1,2</sup>
  - ⇒ Source 8 becomes “Server 2”<sup>1,2</sup>
  - ⇒ Source 9 becomes “Server 3”<sup>2</sup>
  - ⇒ Source 10 becomes “Server 4”<sup>2</sup>

1: AAS-2 model  
2: AAS-4 model

---

**NOTE:** When installing an AAS, only one AAS can be present on the network.

---

- Press **MENU** to return to the Installer Tools menu.

**Set the Number of Rooms**

Set the number of rooms so the AES does not display unused rooms during configuration and operation.

- Open Installer Tools as described on page 24, select **Set Number of Rooms**, and press the **ENTER** button.

*Set the Number of Rooms*

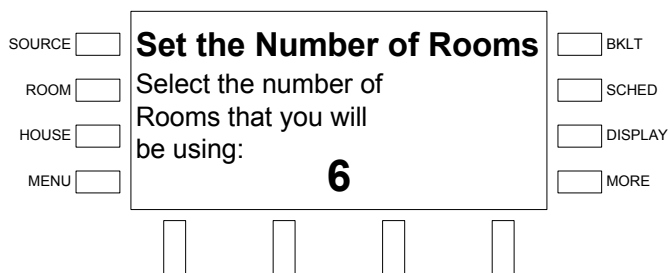

- Use the selection knob to select the number of rooms. To cancel and return to the Installer Tools menu, press **MENU**.
- To confirm, press the **ENTER** button and return to the Installer Tools menu.

**Name Rooms**

This screen allows you to customize the name of each room displayed on the LCD.

- Open Installer Tools as described on page 24, select **Name Rooms**, and press the **ENTER** button.

*Name Rooms*

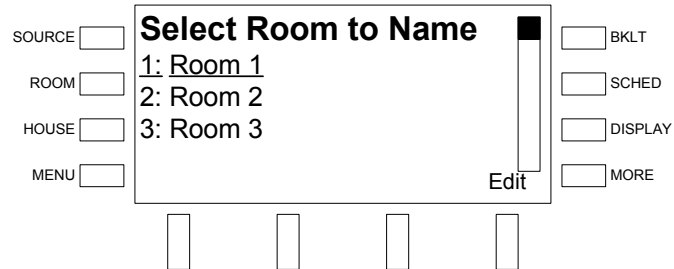

- Turn the selection knob to select the room to be named and press the soft button labeled **Edit** (or press the **ENTER** button). To cancel and return to the Installer Tools menu, press **MENU**.
- To use one of the factory-installed names, turn the selection knob clockwise or counterclockwise to display the desired room name and press **ENTER**.
- To enter a custom name, turn the selection knob until **[Custom Name]** is displayed and press **ENTER**.

*Edit Room Name*

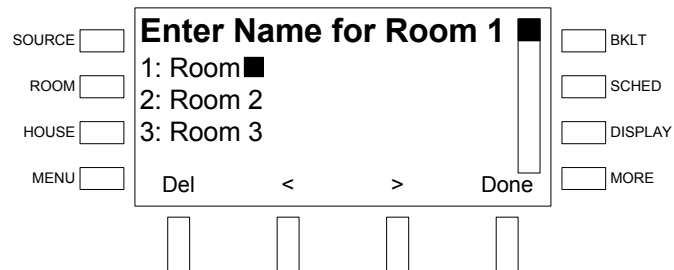

⇒ Select letters (upper and lower-case), numbers, or other characters by turning the selection knob until the desired letter, number, or other character is displayed on the LCD. Move the cursor to another position by pressing the soft buttons labeled **<** and **>**. To delete a character, press the soft button marked **Del**.

---

**NOTE:** The maximum length for any room name is 16 characters.

---

- ⇒ After entering the new room name, press **Done** to save the name and return to the list of room names.
- If all of the rooms have been named/renamed, press **MENU** to return to the Installer Tools menu.

**Name Sources**

This screen allows you to customize the name of each source displayed on the LCD.

- Open Installer Tools as described on page 24, select **Name Sources**, and press the **ENTER** button.

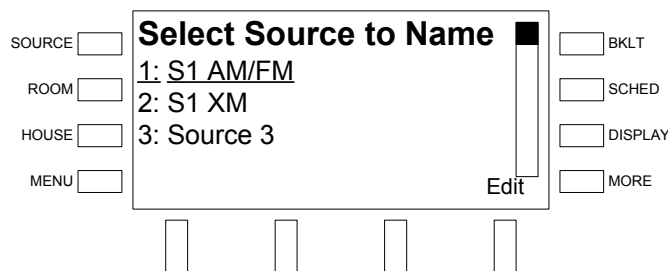
**Name Sources**

- Turn the selection knob to select the source to be named and press the soft button labeled **Edit** (or press the **ENTER** button). To cancel and return to the Installer Tools menu, press **MENU**.
- To use one of the factory-installed names, turn the selection knob clockwise or counterclockwise to display the desired source name and press **ENTER**.
- To enter a custom name, turn the selection knob until [**Custom Name**] is displayed and press **ENTER**.

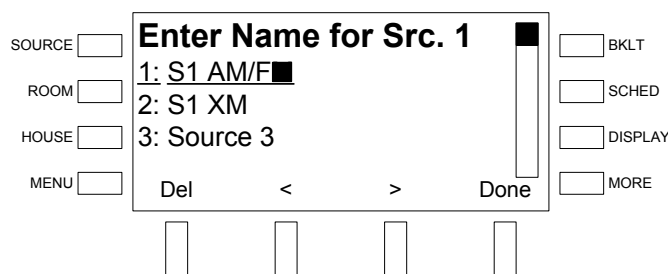
**Edit Source Name**

- ⇒ Select letters (upper and lower-case), numbers, or other characters by turning the selection knob until the desired letter, number, or other character is displayed on the LCD. Move the cursor to another position by pressing the soft buttons labeled **<** and **>**. To delete a character, press the soft button marked **Del**.

---

**NOTE:** The maximum length for any source name is 16 characters.

---

- ⇒ After entering the new source name, press **Done** to save the name and return to the list of sources.
- If all of the sources have been named/renamed, press **MENU** to return to the Installer Tools menu.

**Hide Sources**

This screen allows you to hide sources from the list of available sources. This screen also allows you to reveal sources that were previously hidden.

- Open Installer Tools as described on page 24, select **Hide Sources**, and press the **ENTER** button.



*Hide Sources*

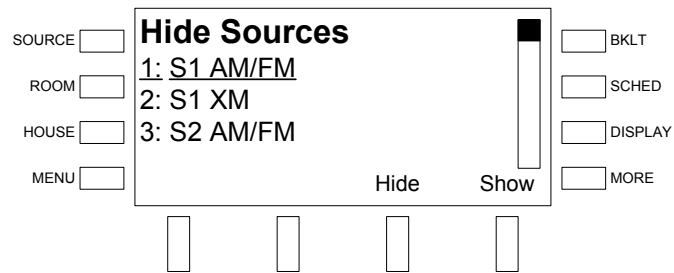

- To hide a source, turn the selection knob to select the source to be hidden and press the soft button labeled **Hide**. Hidden sources are indicated with an asterisk (\*). After all of the sources to be hidden are designated as such, press **MENU** to return to the Installer Tools menu.
- To make a source visible, turn the selection knob to select the source to be made visible and press the soft button labeled **Show**. After all of the sources to be shown are designated as such, press **MENU** to return to the Installer Tools menu.

**Identify Keypads**

This screen allows you to identify keypads and APAD devices that are connected to the AES.

- Open Installer Tools as described on page 24, select **Identify Keypads**, and press the **ENTER** button.

**NOTE:** Any attached AAE will automatically be identified by the AES during this step.

*Identify Keypads Warning*

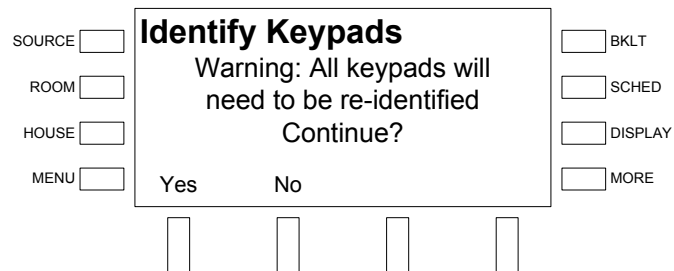

- Press the soft button labeled **Yes** to proceed and clear previously stored keypad identification data or press **No** to cancel.

*Select Keypad Type*

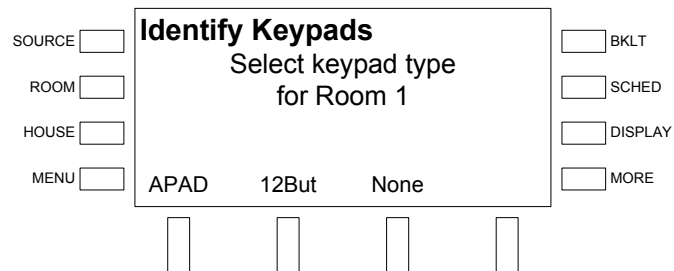

- Press the appropriate soft button to select the control device type (APAD or keypad) for the first room controlled by the AES (Room Output 1). If there is no control device for that room, press the soft button labeled **None**.
- Follow the onscreen instructions for identifying the device. After identifying the device, the AES will prompt for the next room's control device.

---

**NOTE:** If a device is not identified within two minutes, the AES will indicate that the keypad was not found. Try again by pressing the soft button labeled **Yes** or cancel the process by selecting the soft button labeled **Abort**.

---

- Repeat the procedure until control devices for all of the specified rooms (refer to page 26) have been identified.

**Load APADs**

APAD devices may need to be programmed to work with the AES. If a connected APAD does not display controls for the AES, perform the following:

- Open Installer Tools as described on page 24, select **Load APADs**, and press the **ENTER** button.

*Load APADs Warning*

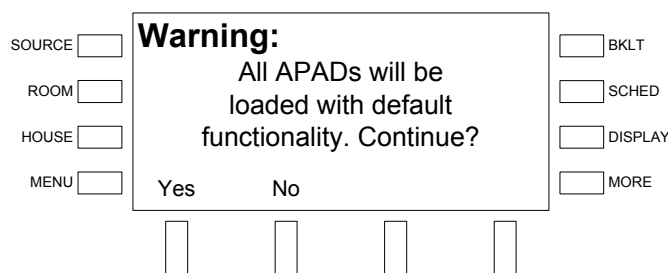

- Press the soft button labeled **Yes** to proceed and load the required files to connected APADs or press **No** to cancel.

**Configure Keypads**

This screen allows you to assign sources to the top six keys of a C2N-DBF12 keypad. The source assignment is applied to every C2N-DBF12 keypad that is connected to the system. The functions of the bottom six keys cannot be changed when using the out-of-the-box program.

- Open Installer Tools as described on page 24, select **Configure Keypads**, and press the **ENTER** button.

*Select Button To Map*

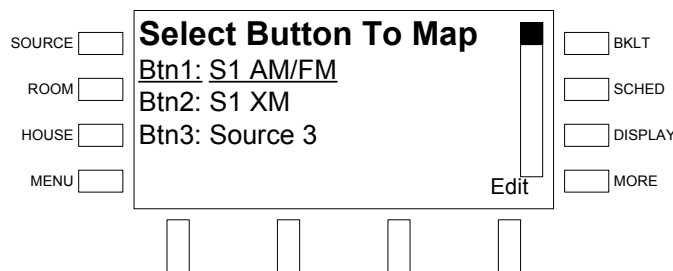

- Turn the selection knob to select the button to be mapped and press the **ENTER** button or the soft button labeled **Edit**. To cancel and return to the Installer Tools menu, press **MENU**.

**Select Source for Button and Button Layout**

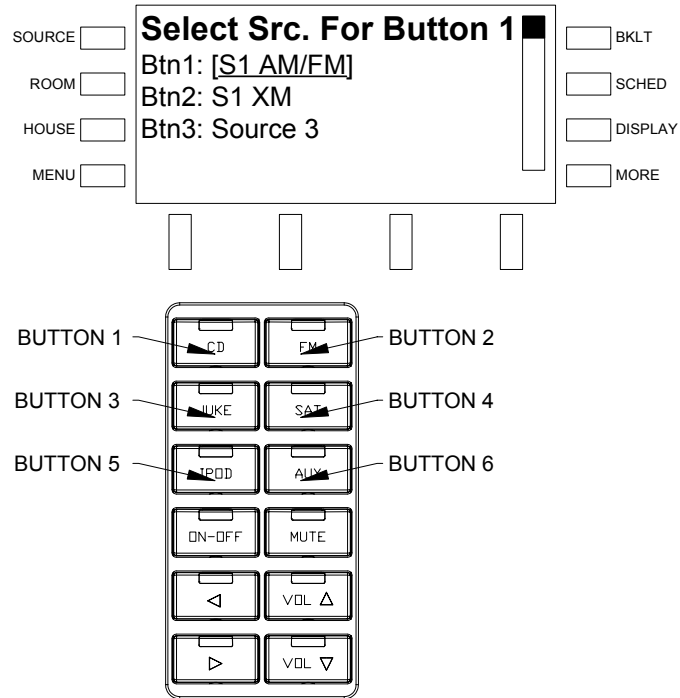

- Select the source for the button by turning the selection knob until the desired source is displayed on the LCD. If a button is not to be used, select **Not Used**.
- After selecting the source, press the **ENTER** button to save the assignment and return to the list of buttons. If all of the buttons have been assigned/reassigned, press **MENU** to return to the Installer Tools menu.

**Restore Default Settings**

The AES can be restored to its default factory settings from the front panel. All settings that have been made with Installer Tools, as well as room and source audio settings will be reset to their factory defaults.

- Open Installer Tools as described on page 24, select **Restore Defaults**, and press the **ENTER** button.

**Restore Defaults Warning**

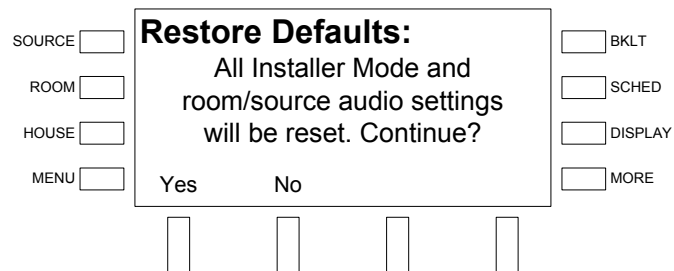

- Press the soft button labeled **Yes** to proceed and restore the default settings or press **No** to cancel.

**About**

This screen allows you to view information about the AES.

- Open Installer Tools as described on page 24, select **About**, and press the **ENTER** button. The IP address, IP mask, and Hostname of the AES are displayed on the LCD.

*About*

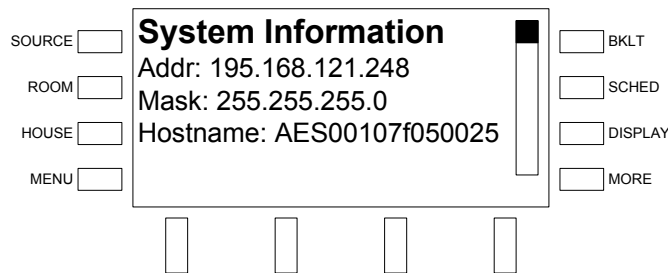

- Turn the selection knob to display additional information.

## Configure Sources

The gain of each source can be customized from the AES control panel.

**Adjust the Gain of a Source**

To adjust a source's gain:

- Select a source to adjust by pressing **SOURCE** and using the selection knob to select a source.
- Press and hold the **SOURCE** and **MORE** buttons at the same time to open the Gain control. The soft button labels will change to show the available control option.

*Source Setup Menu*

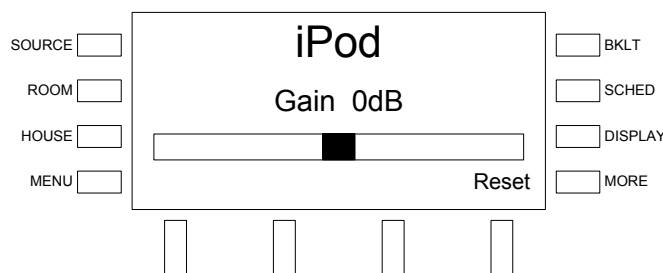

- Adjust the gain level with the selection knob. Turn clockwise to raise the gain level or counterclockwise to lower the gain level. Press the soft button labeled **Reset** to set the gain level to 0dB.
- Press **MENU** to exit.

## Configure Rooms

The sound quality, minimum volume, maximum volume and startup volume settings, of each room can be customized from the AES control panel.

*Access the Room Setup Mode*

- Select a room to configure by pressing a room button. Alternatively, press **ROOM** and select the room with the selection knob.
- Press the **ROOM** and **MORE** buttons at the same time to open the Room Setup menu. The soft button labels will change to show the available control options.

*Room Setup Menu*

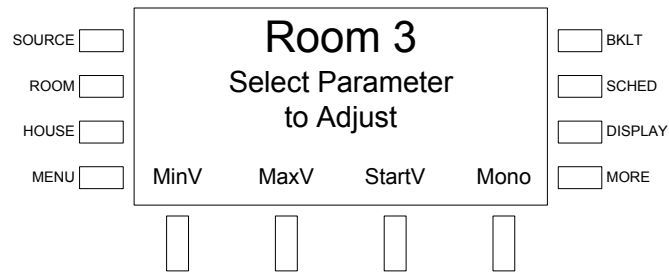

Parameters that can be adjusted include:

- ⇒ Minimum Volume
- ⇒ Maximum Volume
- ⇒ Startup Volume
- ⇒ Mono/Stereo

*Adjust the Minimum Volume*

The minimum volume establishes the lowest volume level setting for a room. The minimum volume settings of each room can be adjusted independently.

- Access the Room Setup mode as described on page 33.
- Press the soft button labeled **MinV** to open the Minimum Volume control.

*Minimum Volume Control*

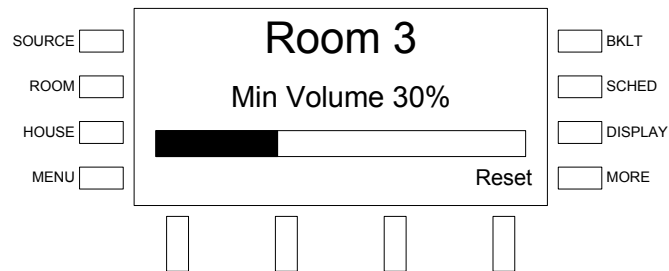

- Adjust the minimum volume with the selection knob. Turn clockwise to raise the minimum volume or counterclockwise to lower the minimum volume. The highest minimum volume setting is 30%. Press the soft button labeled **Reset** to set the volume level to 0%.

---

**NOTE:** Other rooms can be adjusted by pressing a different room button.

---

- Press **MENU** to return to the Room Setup menu.

**Adjust the Maximum Volume**

The maximum volume establishes the highest volume level setting for a room. The maximum volume settings of each room can be adjusted independently.

- Access the Room Setup mode as described on page 33.
- Press the soft button labeled **MaxV** to open the Maximum Volume control.

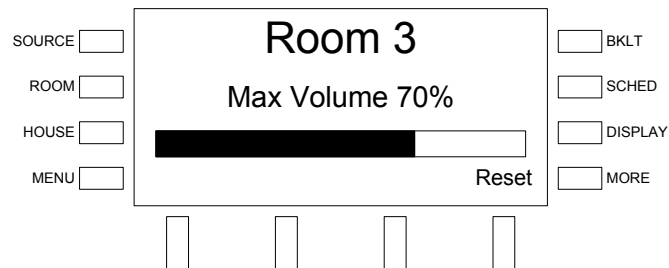
**Maximum Volume Control**

- Adjust the maximum volume with the selection knob. Turn clockwise to raise the maximum volume or counterclockwise to lower the maximum volume. The lowest maximum volume setting is 70%. Press the soft button labeled **Reset** to set the volume level to 100%.

---

**NOTE:** Other rooms can be adjusted by pressing a different room button.

---

- Press **MENU** to return to the Room Setup menu.

**Adjust the Startup Volume**

The startup volume establishes the volume level setting for a room when a room is turned on. The startup volume settings of each room can be adjusted independently.

- Access the Room Setup mode as described on page 33.
- Press the soft button labeled **StartV** to open the Startup Volume control.

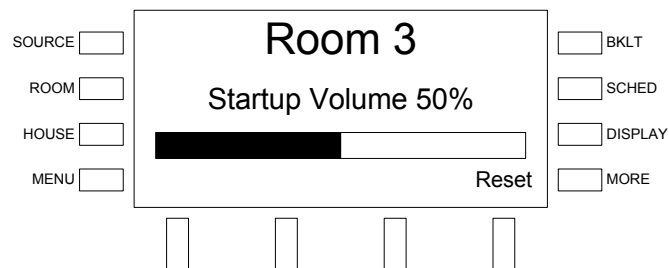
**Startup Volume Control**

- Adjust the startup volume with the selection knob. Turn clockwise to raise the startup volume or counterclockwise to lower the startup volume. The maximum startup volume setting is 50%. Press the soft button labeled **Reset** to set the volume level to 30%.

---

**NOTE:** Other rooms can be adjusted by pressing a different room button.

---

- Press **MENU** to return to the Room Setup menu.

**Set Mono or Stereo Mode**

The audio sent to the speakers in each room can be set for either stereo or mono. When set to stereo, the audio signal is separated into left and right channels for distribution to left and right speakers. When set to mono, the audio signal is combined into one signal for use in larger rooms where stereo separation is not practical. The mono/stereo settings of each room can be adjusted independently.

- Access the Room Setup mode as described on page 33.
- Press the soft button labeled **Mono** to open the Stereo/Mono control.

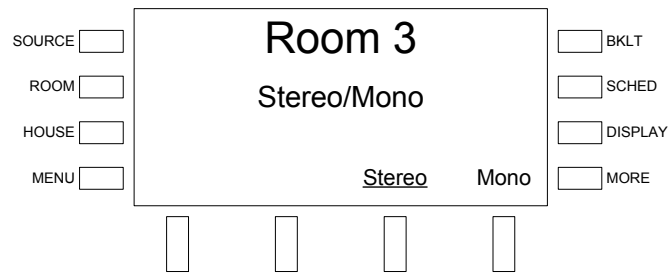
**Stereo/Mono Control**

- The selected mode is underlined on the lower-right side of the LCD. Press the soft button labeled **Stereo** to select the stereo mode. Press the soft button labeled **Mono** to select the mono mode.

---

**NOTE:** Other rooms can be adjusted by pressing a different room button.

---

- Press **MENU** to return to the Room Setup menu.

## Configure Preset Groups

Preset groups can be created to group speakers in adjacent rooms with a specified source, or switch into a whole-house “party” mode, by letting the user link a source with any number of rooms. Changing the source in any one room changes the source in all of the rooms in the preset group.

### Edit a Preset Group

To edit a preset group:

- Press and hold a preset group button for approximately five seconds to view the Edit Group controls shown below. The selected preset group button will flash.

#### Edit Group Controls

- Select the rooms in the preset group by pressing the corresponding room buttons on the AES or AAE (if connected). Each room button’s LED will turn on. Press again to remove the room from the preset group. The room button’s LED will turn off.
- Select a source for the preset group by pressing the soft button labeled **Source**. Turn the selection knob clockwise or counterclockwise until the desired source is displayed on the LCD.
- Press the soft button labeled **Name** to change the name of the preset group. The group name controls will be displayed. Select letters (upper and lower-case) by turning the selection knob until the desired letter is displayed. Move the cursor to another position by pressing the soft buttons labeled ◀ and ▶. To delete a character, press the soft button marked **Del**.

---

**NOTE:** The maximum length for any preset group name is 16 characters.

---

#### Edit Group Name Controls

- After editing the preset group, press **Done** to save the changes and return to the previous operating mode.



## Operation

Prior to using this section, refer to the QuickStart Guide (Doc. 6457) that is included with the AES.

For instructions on using the APAD and the C2N-DBF12 with the AES refer to the latest version of the Out-Of-The-Box Functionality Guide (Doc. 6493).

Operating the AES is broken down into three modes:

- *Source Mode*
- *Room Mode*
- Turn Off the System

### Source Mode

*Source mode* is used to select and control sources that are connected to the AES. A selected source can also be routed to any room or rooms connected to the AES or a connected AAE.

#### Select a Source

To select a source:

- Press **Source** to put the AES in *Source mode*. The current controlled source is displayed on the LCD.

#### Source Mode

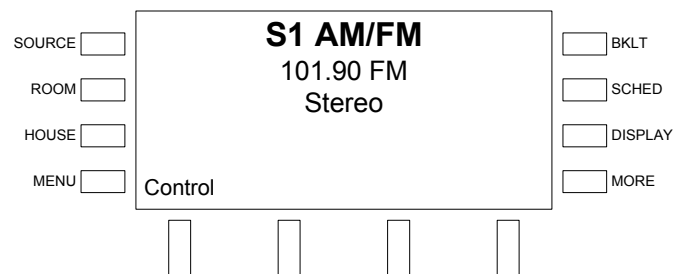

- Turn the selection knob until the desired source is displayed on the LCD. Rooms that are connected to the displayed source are indicated on the room buttons.
- Press the **ENTER** button (or the soft button labeled **Control** if it is a device that can be controlled by the AES) to select and control the source.

When using the out-of-the-box functionality, the AES can control tuner cards installed in slots 1 and 2, an iPod connected to a CEN-IDOC, and an AAS (when connected).

### Controlling a Tuner

A tuner card installed in either slot one or two can be controlled by the AES front panel.

The following assumes that a tuner card has been installed in slot one or two (or both) as described in the tuner card's guide.

*Find the Tuner Controls*

- Place the AES in the *Source* mode (see “Select a Source” on page 37).
- Turn the selection knob to the desired tuner source (sources 1 and 2 for a tuner card installed in slot one, sources 3 and 4 for a tuner card installed in slot two). The frequency/channel and other information will be displayed.

**FM Radio Source**



**XM Radio Source**

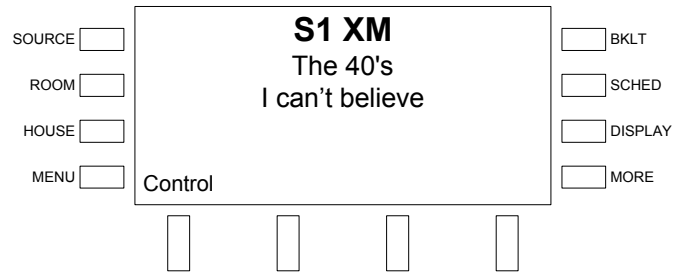

**SIRIUS Radio Source**

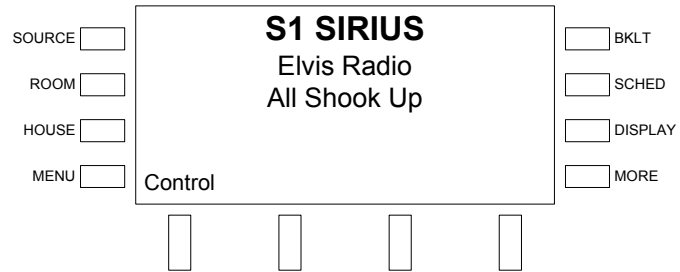

- Press the soft button labeled **Control** or press **ENTER** to open the tuner controls.

**Control the AM/FM Tuner**

The AM/FM tuner controls allow access to the AM/FM tuner functions. The tuner controls can recall and store presets, tune and scan stations on the frequency band, or change frequency bands (AM or FM).

*AM/FM Controls*

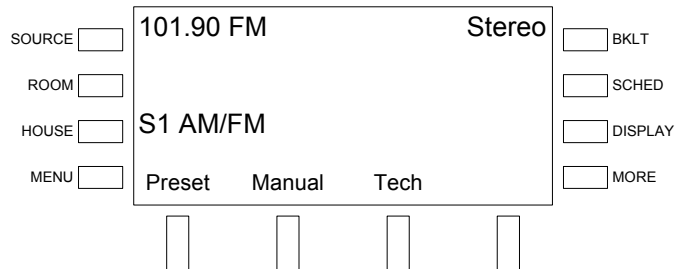

- Presets:  
Use presets to recall and store favorite stations.

⇒ To recall a preset:

- ❖ Press the soft button labeled **Preset**.

*Preset Controls*

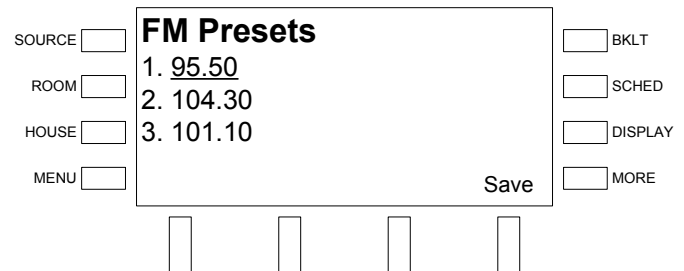

- ❖ Select a preset location with the selection knob and press the **ENTER** button.

⇒ To store a preset:

- ❖ Tune the desired station using the *Manual* tuning mode.
- ❖ Press the soft button labeled **Preset**.

*Preset Controls*

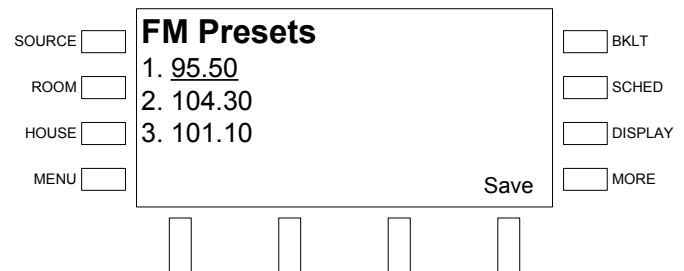

- ❖ Select a preset location with the selection knob and press the soft button labeled **Save**.

**Replace Preset Prompt**

- ❖ Press the soft button labeled **OK** to confirm or the soft button labeled **Cancel** to cancel.

- **Manual Mode:**

Press the soft button labeled **Manual** to operate in the *Manual* mode.

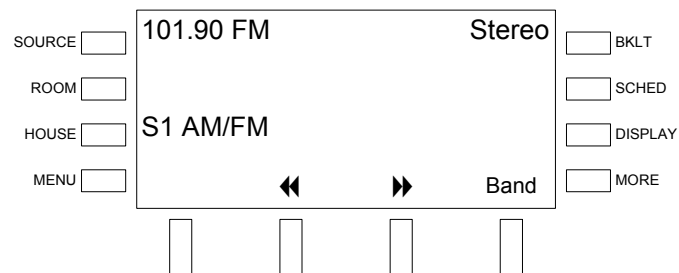
**Manual Mode**

When operating in *Manual* mode, the tuner can be manually tuned or it can scan each clear frequency for five seconds before seeking the next clear frequency. When in *Manual* mode, the frequency band can also be changed.

- ⇒ **Manual Tuning**

Turn the selection knob clockwise to manually increase the frequency; or turn counterclockwise to manually decrease the frequency.

- ⇒ **Scanning:**

- ❖ Press the soft button labeled **▶▶** to start a scan that increases in frequency; or press the soft button labeled **◀◀** to start a scan that decreases in frequency to the next clear frequency.

- ❖ Stop the scan by pressing either of the scan control buttons. The scan automatically stops when the tuner reaches the frequency where the scan originally started.

- ⇒ **Band selection:**

To switch between the AM and FM frequency band, press the soft button labeled **Band**.

- **Signal Strength:**

To view the signal strength of the tuned frequency:

- ⇒ Press the soft button labeled **Tech** to view the signal strength.

**Signal Strength (FM Shown)**

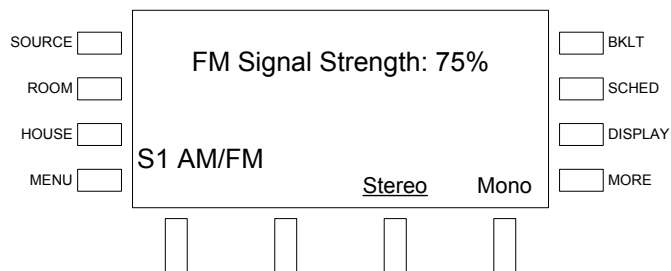

⇒ To return to the tuner controls, press the **MENU** button.

**Control the XM Tuner**

The XM tuner controls allow access to XM tuner functions such as presets, categories, and channels, as well as viewing radio signal strength.

**XM Radio Controls**

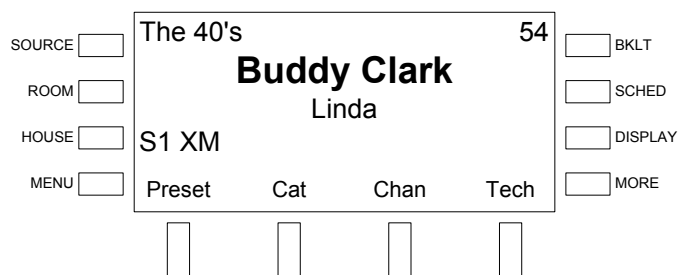

- Presets:  
Use presets to quickly recall favorite stations.

⇒ To recall a preset:

- ❖ Press the soft button labeled **Preset**.

**Preset Controls**

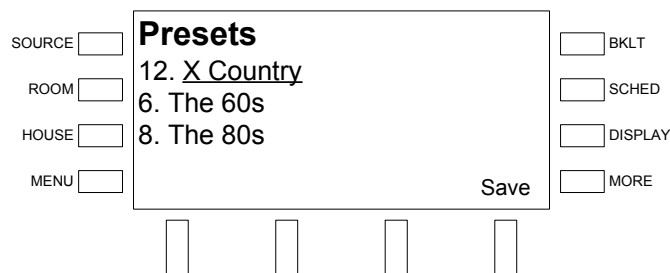

- ❖ Select a preset location with the selection knob and press the **ENTER** button.

⇒ To store a preset:

- ❖ Tune the desired station using the *Category* or *Channel* modes.
- ❖ Press the soft button labeled **Preset**.

**Preset Controls**

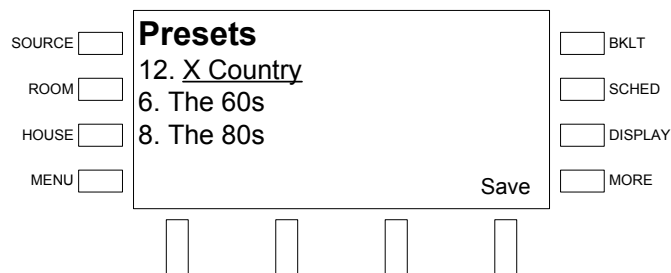

- ❖ Select a preset location with the selection knob and press the soft button labeled **Save**.

**Replace Preset Prompt**



- ❖ Press the soft button labeled **OK** to confirm or the soft button labeled **Cancel** to cancel.

- **Category Mode:**  
The *Category* mode lets you select a channel based on a category.
  - ⇒ Press the soft button labeled **Cat** to view available channel categories:

**Category Controls**

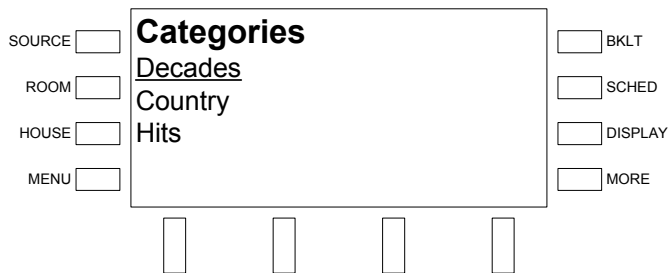

- ⇒ Turn the selection knob to view the list of available categories.
- ⇒ Press the **ENTER** button to select a category.
- ⇒ Turn the selection knob to view the list of channels in the category.
- ⇒ Press the **ENTER** button to select a channel.

- **Channel Mode:**  
The *Channel* mode lets you select a channel based on the channel name.
  - ⇒ Press the soft button labeled **Chan** to view available channels.

**Channel Controls**

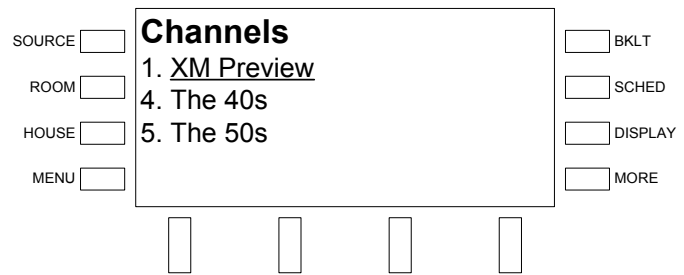

⇒ Turn the selection knob to view the list of available channels.

---

**NOTE:** Channel 0 displays the radio ID which is required for subscription to the XM radio service.

---

⇒ Press the **ENTER** button to select a channel.

- **Technical Section:**  
The technical section displays repeater and satellite signal strength in graphic form as well as the radio ID.

⇒ Press the soft button labeled **Tech** to view technical information about the XM receiver.

**Technical Information**

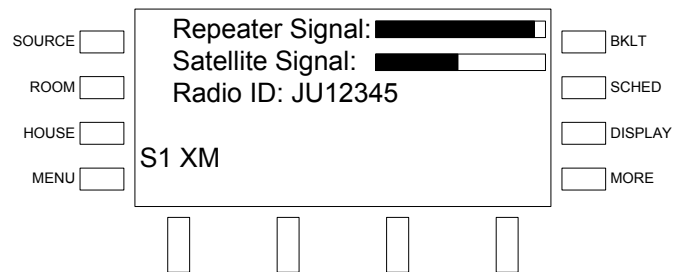

⇒ Press the **MENU** button to return to the XM Radio controls.

**Control the SIRIUS Tuner**

The SIRIUS tuner controls allow access to SIRIUS tuner functions such as presets, categories, and channels, as well as viewing radio signal strength.

**SIRIUS Radio Controls**

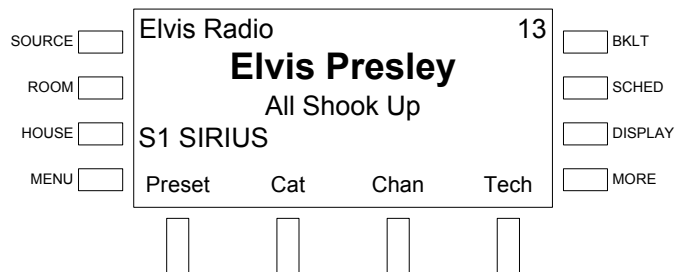

- **Presets:**  
Use presets to quickly recall favorite stations.

⇒ To recall a preset, press the soft button labeled **Preset**.

**Preset Controls**

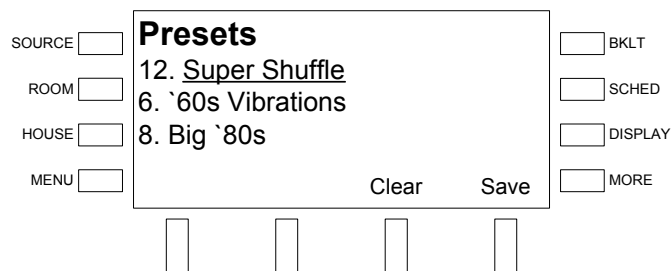

- ⇒ Select a preset location with the selection knob and press the **ENTER** button. If the channel is locked, you will be prompted to enter a Personal Identification Number (PIN).

**Enter PIN**

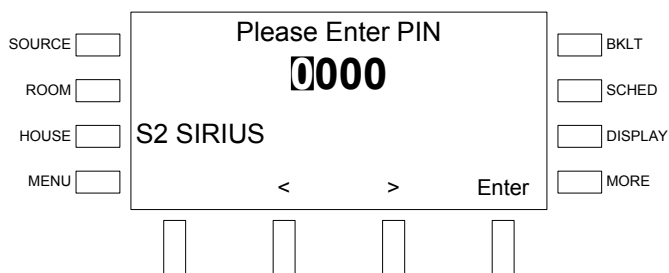

- ❖ Enter the first digit of the PIN (the factory default is 1234) by turning the selection knob clockwise or counterclockwise until the desired digit is displayed.
- ❖ Press the soft buttons labeled < or > to move the cursor to the previous or next digit and enter the rest of the PIN.
- ❖ When the PIN is displayed, press the soft button labeled **ENTER** to unlock the channel.

- ⇒ To store a preset:

- ❖ Tune the desired station using the *Category* or *Channel* modes.
- ❖ Press the soft button labeled **Preset**.

**Preset Controls**

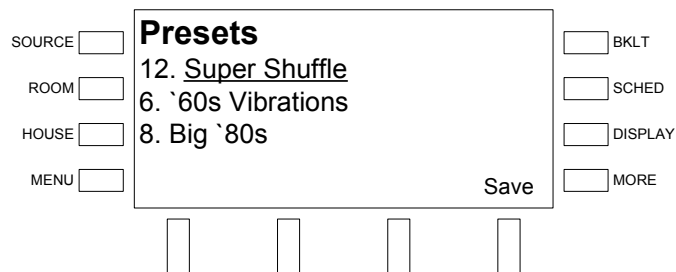

- ❖ Select a preset location with the selection knob and press the soft button labeled **Save**.



**Replace Preset Prompt**

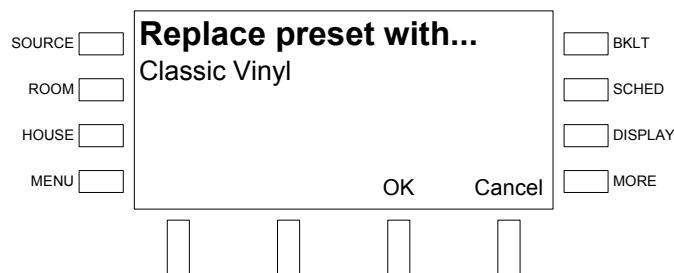

- ❖ Press the soft button labeled **OK** to confirm or the soft button labeled **Cancel** to cancel.

⇒ To clear a preset location:

- ❖ Select a preset with the selection knob and press the soft button labeled **Clear**.

**Clear Preset**

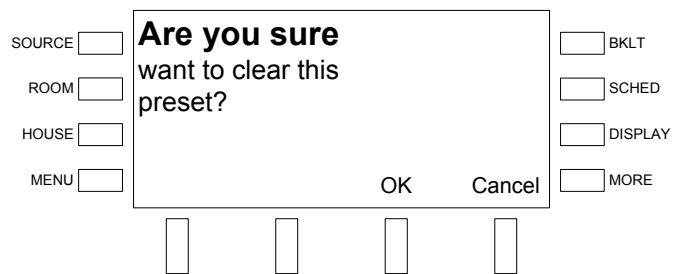

- ❖ Press the soft button labeled **OK** to clear the preset location or press the soft button labeled **Cancel** to cancel.

- **Category Mode:**

The *Category* mode lets you select a channel based on a category.

⇒ Press the soft button labeled **Cat** to view available channel categories:

**Category Controls**

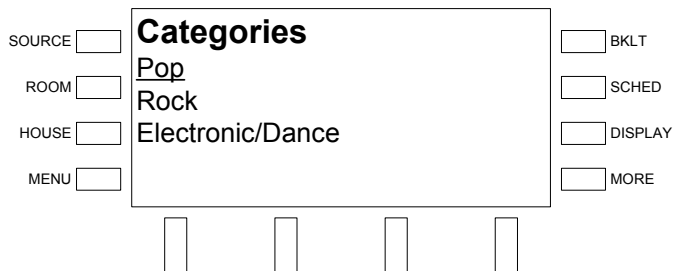

- ⇒ Turn the selection knob to view the list of available categories.
- ⇒ Press the **ENTER** button to select a category.
- ⇒ Turn the selection knob to view the list of channels in the category.

**NOTE:** Some channels may be locked or hidden from view. To select which channels are locked or hidden from view, refer to “Technical Section” on page 47.

⇒ Press the **ENTER** button to select a channel. If the channel is locked, you will be prompted to enter a Personal Identification Number (PIN).

**Enter PIN**

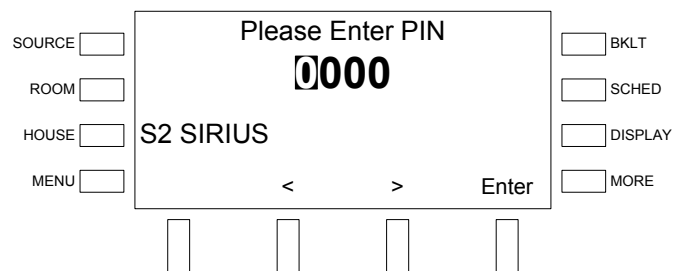

- ❖ Enter the first digit of the PIN (the factory default is 1234) by turning the selection knob clockwise or counterclockwise until the desired digit is displayed.
- ❖ Press the soft buttons labeled < or > to move the cursor to the previous or next digit and enter the rest of the PIN.
- ❖ When the PIN is displayed, press the soft button labeled **ENTER** to unlock the channel.

- **Channel Mode:**

The *Channel* mode lets you select a channel based on the channel name.

⇒ Press the soft button labeled **Chan** to view available channels.

**Channel Controls**

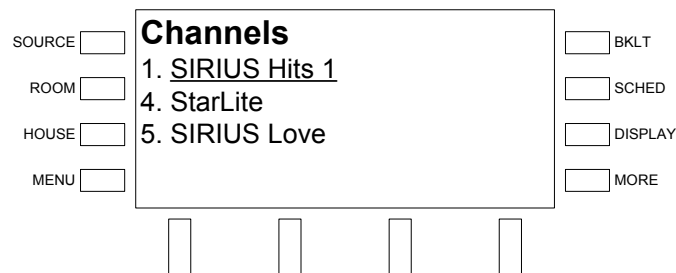

⇒ Turn the selection knob to view the list of available channels.

**NOTE:** Some channels may be locked or hidden from view. To select which channels are locked or hidden from view, refer to “Technical Section” on page 47.

**NOTE:** Channel 0 displays the radio ID which is required for subscription to the SIRIUS radio service.

⇒ Press the **ENTER** button to select a channel. If the channel is locked, you will be prompted to enter a Personal Identification Number (PIN).

**Enter PIN**

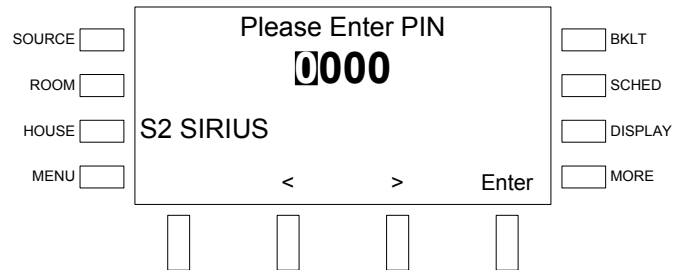

- ❖ Enter the first digit of the PIN (the factory default is 1234) by turning the selection knob clockwise or counterclockwise until the desired digit is displayed.
- ❖ Press the soft buttons labeled < or > to move the cursor to the previous or next digit and enter the rest of the PIN.
- ❖ When the PIN is displayed, press the soft button labeled **ENTER** to unlock the channel.

- **Technical Section:**

The technical section displays repeater and satellite signal strength in graphic form as well as the radio ID. The technical information section also contains controls for viewing SIRIUS tuner information, locking channels (accessible by entering a Personal Identification Number), hiding/exposing channels from the channel list (accessible by entering a Personal Identification Number), and resetting the Personal Identification Number (PIN).

⇒ Press the soft button labeled **Tech** to view information about the repeater signal strength, satellite signal strength, and the radio ID. Buttons for viewing tuner card information and tuner setup will also be displayed.

**Technical Information**

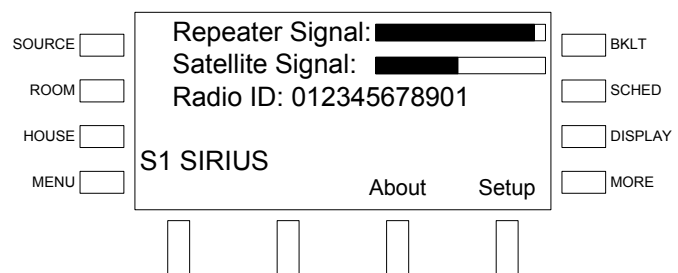

⇒ To view firmware and other information about the tuner card:

- ❖ Press the soft button labeled **About**.

**About**

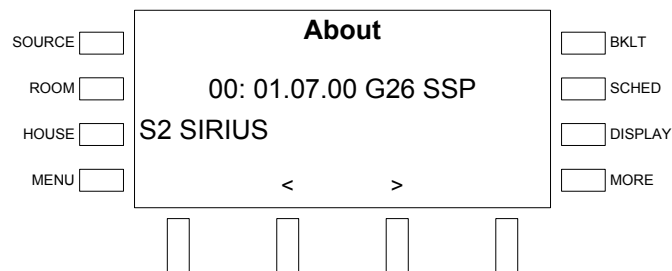

- ❖ Press the soft buttons labeled < or > to scroll through the available information.
- ❖ Press the **MENU** button to return to the SIRIUS technology section controls.

⇒ To hide or unhide channels from the channel listing:

- ❖ Press the soft button labeled **Setup**. A prompt to enter a Personal Identification Number (PIN) will be displayed.

**Enter PIN**

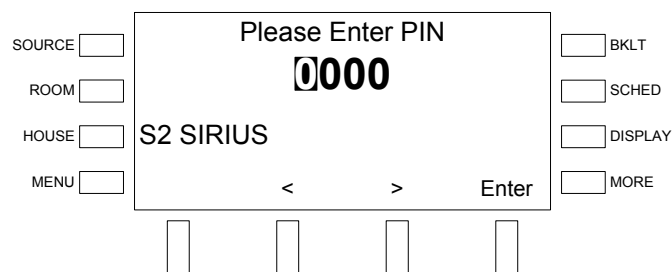

- ❖ Enter the first digit of the PIN (the factory default is 1234) by turning the selection knob clockwise or counterclockwise until the desired digit is displayed.
- ❖ Press the soft buttons labeled < or > to move the cursor to the previous or next digit and enter the rest of the PIN.
- ❖ When the PIN is displayed, press the soft button labeled **ENTER** to open the Setup controls.

**Setup Controls**

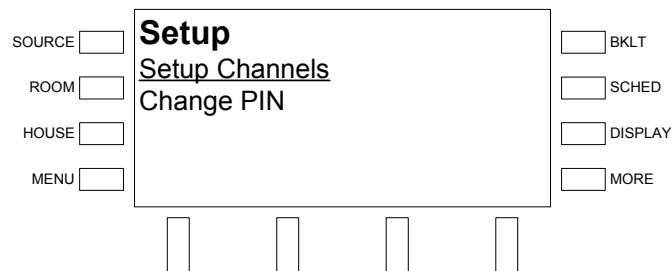

- ❖ Turn the selection knob clockwise or counterclockwise to highlight “Setup Channels” and press the **ENTER** button to display a list of all of the SIRIUS channels.

*Setup Controls—Channel Listing*



- ❖ Turn the selection knob to highlight the channel that is to be hidden or unhidden and press the **ENTER** button to open the Lock/Hide channel controls

*Lock/Hide Channel Controls*

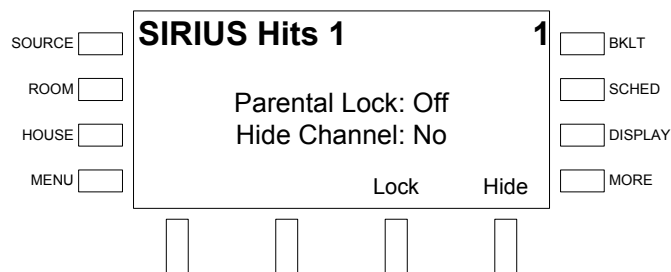

- ❖ If a channel is to be hidden, press the soft button labeled **Hide**. If a hidden channel is to be unhidden, press the soft button labeled **Hide**.
- ❖ Press the **MENU** button to return to the SIRIUS technology section controls.

⇒ To lock or unlock channels:

- ❖ Press the soft button labeled **Setup**. A prompt to enter a Personal Identification Number (PIN) will be displayed. Enter the PIN as described on page 48 to open the Setup controls.

*Setup Controls*

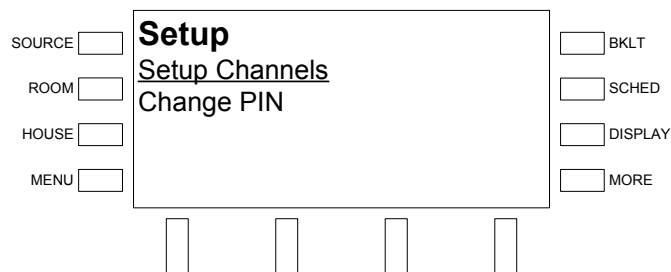

- ❖ Turn the selection knob clockwise or counterclockwise to highlight “Setup Channels” and press the **ENTER** button to display a list of all of the SIRIUS channels.

*Setup Controls—Channel Listing*



- ❖ Turn the selection knob to highlight the channel that is to be hidden or unhidden and press the **ENTER** button to open the Lock/Hide channel controls

*Lock/Hide Channel Controls*

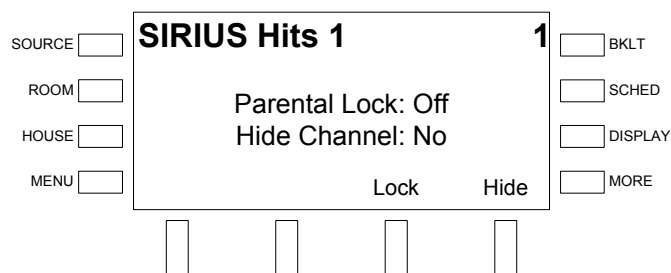

- ❖ If a channel is to be locked, press the soft button labeled **Lock**. If a hidden channel is to be unlocked, press the soft button labeled **Lock**.
- ❖ Press the **MENU** button to return to the SIRIUS technology section controls.

⇒ To change the Personal Identification Number (PIN):

- ❖ Press the soft button labeled **Setup**. A prompt to enter a Personal Identification Number (PIN) will be displayed. Enter the PIN as described on page 48 to open the Setup controls.

*Setup Controls*

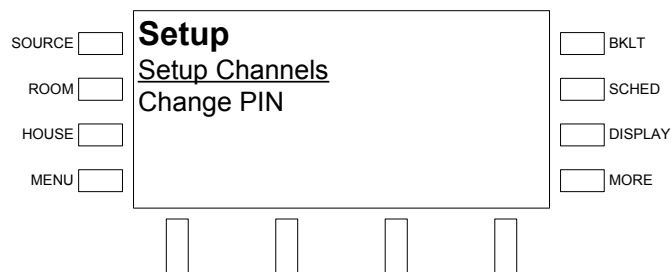

- ❖ Turn the selection knob clockwise or counterclockwise to highlight “Change PIN” and press the **ENTER** button to display the Change PIN controls.

**Change PIN Controls**

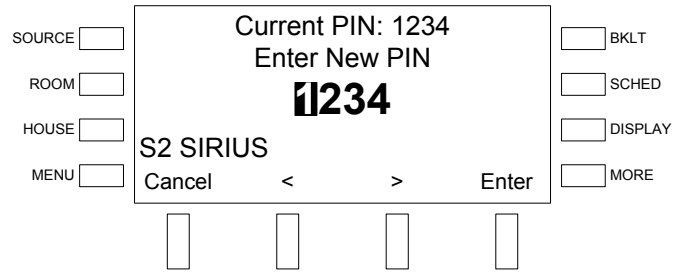

- ❖ Enter the first digit of the PIN by turning the selection knob clockwise or counterclockwise until the desired digit is displayed.
- ❖ Press the soft buttons labeled < or > to move the cursor to the previous or next digit and enter the rest of the PIN.
- ❖ When the new PIN is displayed, press the soft button labeled **ENTER** to open the Setup controls. To cancel, press the soft button labeled **Cancel**.

⇒ To reset the Personal Identification Number (PIN) to the factory default (1234):

- ❖ Press and hold the left-most and right-most soft buttons. After approximately three seconds, the display will indicate that the PIN has been reset to the factory default.
- ❖ Press the soft button labeled **OK**.

⇒ Press the **MENU** button to return to the SIRIUS Radio controls.

**Controlling an iPod**

An Apple iPod can be controlled from the AES front panel with an optional CEN-IDOC Interface for Apple iPod®.

The following assumes that the CEN-IDOC has been installed and an iPod has been connected as described in the CEN-IDOC guide.

**Find the iPod Controls**

- Place the AES in the *Source* mode (refer to “Select a Source” on page 37).
- Turn the selection knob to the iPod source (source #5). The playback status, current track, and artist playing on the iPod will be displayed.

**iPod Source**

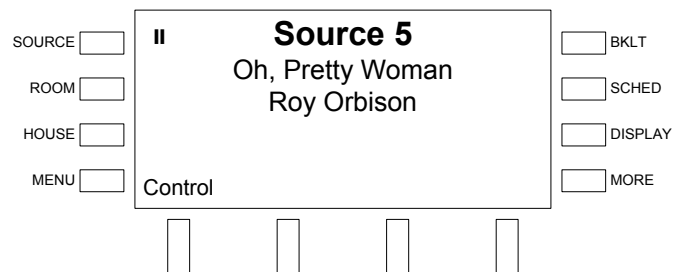

- Press the soft button labeled **Control** to open the iPod controls.

**Play iPod Tracks with the AES**

Use the AES front panel to control playback of tracks on the iPod.

**iPod Playback Controls**

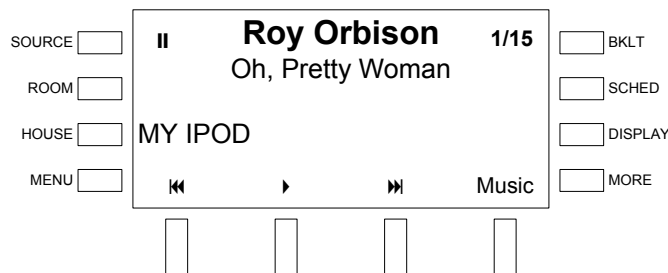

- Press the soft button labeled **⏮** to return to the beginning of the current track or skip to the previous track. If the iPod is paused, press the soft button labeled **▶** to resume playback. If the iPod is currently playing, press the soft button labeled **⏸** to pause playback. Press the soft button labeled **⏭** to skip to the next track. Press the soft button labeled **Music** to open the iPod track menu (for details, refer to “Select Tracks with the AES” below). Press the **DISPLAY** button to toggle between the artist name and the album name. Press the **MORE** button to view more playback options.

**iPod Playback Controls, Page 2**

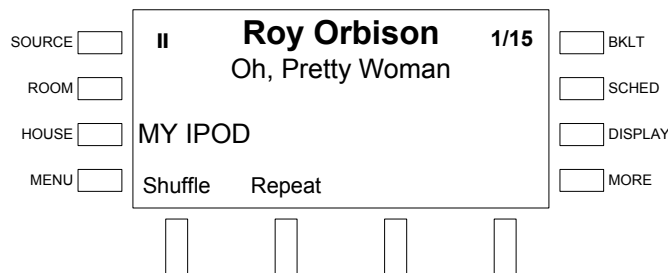

- Press the soft button labeled **Shuffle** to change the *Shuffle* mode of the iPod. Press the soft button labeled **Repeat** to change the repeat mode of the iPod. Press the **MORE** button to return to the main playback controls.

**Select Tracks with the AES**

The AES front panel can be used to select a specific playlist, artist, or track on an iPod.

- Press the soft button labeled **Music** to open the iPod Music menu.

**Music Menu**

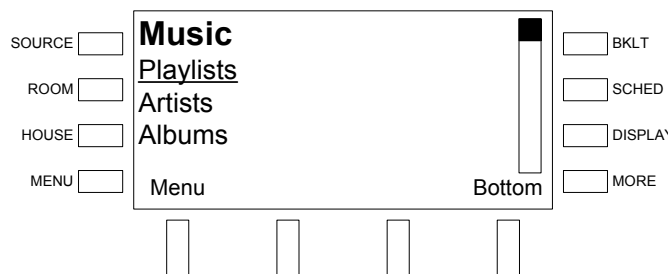



- Turn the selection knob to highlight an item (Playlists, Artists, Albums, etc.) and press the **ENTER** button. The scroll bar indicates the position of the cursor on the displayed list. To jump to the first item in the list, turn the selection knob counterclockwise and press the soft button labeled **Top**. To jump to the last item in the list, turn the selection knob clockwise and press the soft button labeled **Bottom**. If a track name is selected, pressing the **ENTER** button will begin playback.

**Playlist Items**



- When viewing a list of tracks, press the **ENTER** button to play the selected track. To jump to the first item in the list, turn the selection knob counterclockwise and press the soft button labeled **Top**. To jump to the last item in the list, turn the selection knob clockwise and press the soft button labeled **Bottom**. To return to the previous topic (playlist, album, etc.) press the soft button labeled **Back**.

**Controlling an Adagio Audio Server (AAS)**

An AAS can be controlled from the AES front panel.

The following assumes that the AAS has been installed and connected as described in the AAS guide.

*Find the AAS Controls*

- Place the AES in the *Source* mode (refer to “Select a Source” on page 37).
- Turn the selection knob to an AAS source (source 7 for an AAS-1, sources 7 or 8 for an AAS-2, or sources 7, 8, 9, or 10 for an AAS-4 if using out-of-the-box functionality). The playback status, current track, and artist playing on the AAS source will be displayed.

**AAS Source**

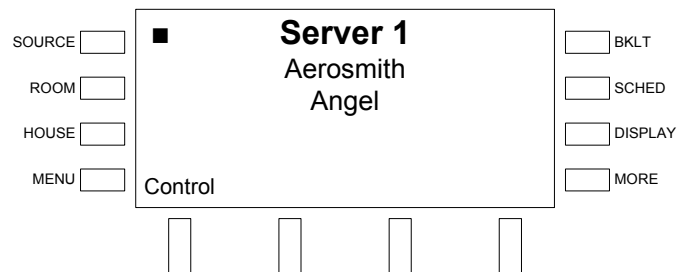

- Press the soft button labeled **Control** to open the AAS controls which displays the playback status, current track, song position in a playlist or queue and operating controls.

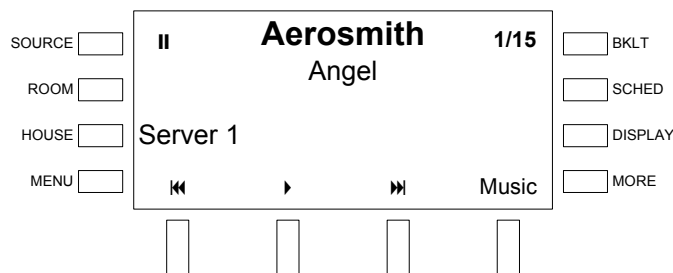
**AAS Controls**

- ⇒ Press the soft button labeled **⏮** to return to the beginning of the current track or skip to the previous track in the queue.
- ⇒ If the AAS output is paused, press the soft button labeled **▶** to resume playback of the current track. If the AAS output is playing, press the soft button labeled **⏸** to pause playback of the current track.
- ⇒ Press the soft button labeled **⏭** to skip to the next track in the queue.
- ⇒ Press the soft button labeled **Music** to open the AAS library and select albums, artists, tracks, etc. to play or add to the queue. Refer to page 56 for details.
- ⇒ Press the **DISPLAY** button to toggle between the artist name and the album name.
- ⇒ Press the **MORE** button to view other controls.

**AAS Controls (Other Controls)**

- ❖ Press the soft button labeled **Shuffle** to access the AAS output's shuffle controls.
- ❖ Press the soft button labeled **Repeat** to access the AAS output's repeat controls.
- ❖ Press the soft button labeled **Queue** to view items in the queue or save a queue as a playlist.
- ❖ Press the **MORE** button to return to the main playback controls.

**Shuffle Control**

Use the AES front panel to control the shuffle mode of an AAS output. Each output's shuffle mode can be controlled independently.

- Open the AAS playback controls as described on page 53, press the **MORE** button, and press the soft button labeled **Shuffle** to open the shuffle controls.

*AAS Shuffle Controls*

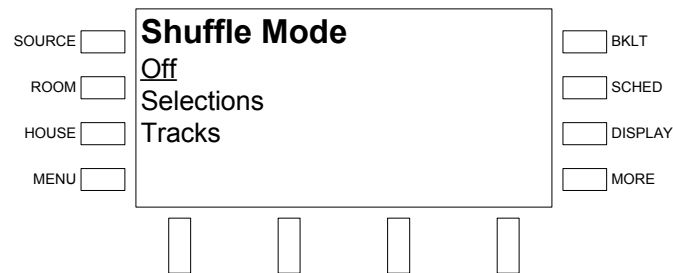

- Turn the selection knob to highlight a shuffle mode.
  - ⇒ *Off* plays all queued items in sequence.
  - ⇒ *Selections* will randomize all items in the play queue. Group items such as Playlists will be played in order. However, the order of group items will be shuffled.
  - ⇒ *Tracks* will shuffle all of the tracks in the play queue.
- Press the **ENTER** button to select the highlighted mode.

**Repeat Control**

Use the AES front panel to control the repeat mode of an AAS output. Each output’s repeat mode can be controlled independently.

- Open the AAS playback controls as described on page 53, press the **MORE** button, and press the soft button labeled **Repeat** to open the repeat controls.

*AAS Repeat Controls*

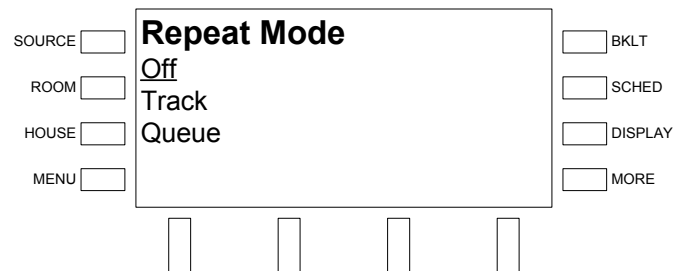

- Turn the selection knob to highlight a repeat mode.
  - ⇒ *Off* plays all queued items once.
  - ⇒ *Track* will repeat the track that is currently playing.
  - ⇒ *Queue* will repeat all of the tracks in the play queue.
- Press the **ENTER** button to select the highlighted mode.

**Queue Management**

The AES front panel can be used to manage items in the play queue and save a queue as a playlist on the AAS.

- Open the AAS playback controls as described on page 53, press the **MORE** button, and press the soft button labeled **Queue** to view the play queue controls.

**Play Queue Controls**

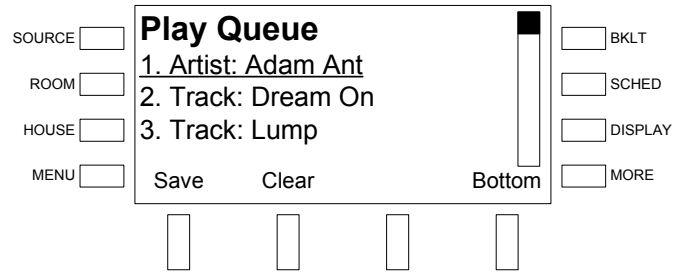

The scroll bar indicates the position of the cursor on the displayed list. To jump to the first item in the list, turn the selection knob counterclockwise and press the soft button labeled **Top**. To jump to the last item in the list, turn the selection knob clockwise and press the soft button labeled **Bottom**.

- To clear an item, turn the selection knob to highlight an item (Artist, Track, etc.) and press the **ENTER** button.
- To clear the play queue, press the soft button labeled **Clear**.
- To save the play queue as a playlist, press the soft button labeled **Save** and create a name for the playlist.

**Enter New Playlist Name**

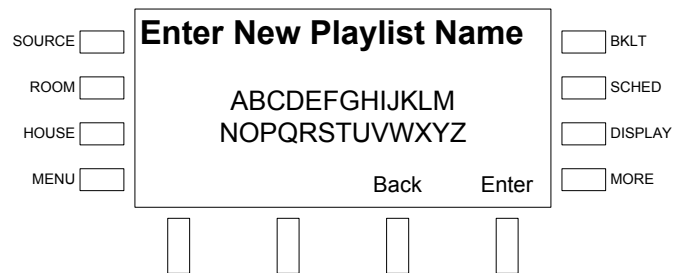

- ⇒ Select a letter with the selection knob and press the **ENTER** button.
- ⇒ To move back a space, press the soft button labeled **Back**.
- ⇒ To save the playlist name, press the soft button labeled **Enter**.

**Browse the AAS Library with the AES**

The AES front panel can be used to select a category (playlist, artist, album, era, etc.) or song in the AAS library. Categories and individual tracks can either be played or added to the play queue.

- Press the soft button labeled **Music** to open the Browse menu.

**Browse Menu**

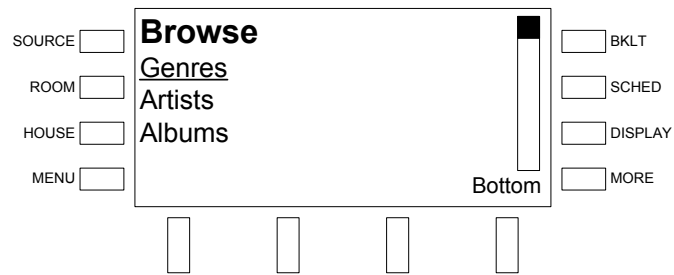

The scroll bar indicates the position of the cursor on the displayed list. To jump to the first item in the list, turn the selection knob counterclockwise and press the soft button labeled **Top**. To jump to the last item in the list, turn the selection knob clockwise and press the soft button labeled **Bottom**.

- To select an item (Genre, Artists, Albums, track, etc.), turn the selection knob to highlight the item and press the **ENTER** button.

For more information on the library structure, refer to the latest version of the AAS guide.

**Track List**

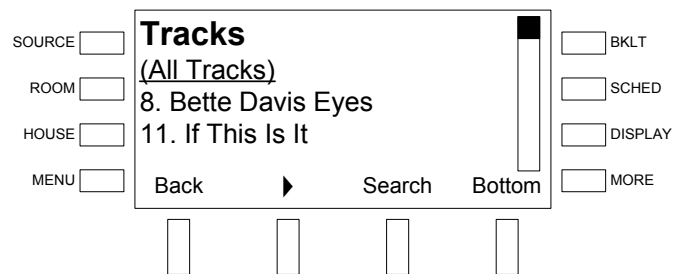

- Press the soft button labeled **▶** to play the current selection and replace the current queue. If “All Tracks” or an individual track is selected, press the **ENTER** button to choose between playing the current selection (thereby replacing the queue) or adding the selected item to the current queue.

**Choose Action**

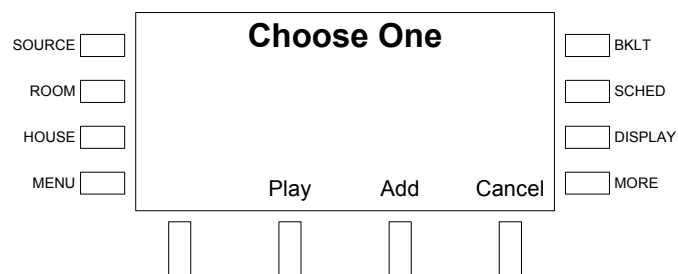

- Press the soft button labeled **Search** to search for a specific item.

*Search the AAS Library with the AES*

**NOTE:** Searches are performed within a category. For example, searching for a song title while browsing artists will not yield any results.

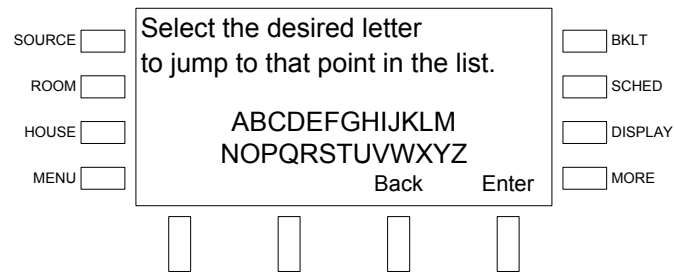
**Search**

- ⇒ Select a letter with the selection knob and press the **ENTER** button.
- ⇒ To move back a space, press the soft button labeled **Back**.
- ⇒ To begin the search, press the soft button labeled **Enter**.

**Route a Source**

Rooms that are connected to the source are indicated on the room buttons.

- Select a source as described on page 37.
- Press room buttons on the AES or AAE to route the selected source to a room.

---

**NOTE:** Volume adjustment is not available when the AES is in *Source* mode. When a source is routed to a room that is not already on, the room will be turned on at the startup volume specified on page 34.

---

## Room Mode

*Room* mode is used to select and control a room that is connected to the AES. If a room button LED is on, then the room is connected to an audio source. If a room button LED is off, then the room is turned off.

### Select a Room

To select a room:

- Press **Room** to put the AES in the *Room* mode. The current selected room is displayed on the LCD.

#### Room Mode

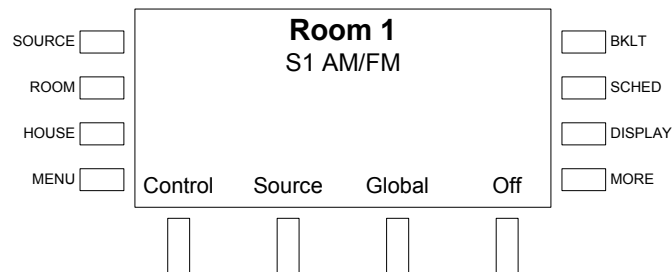

- Turn the selection knob until the desired room is displayed on the LCD. Alternatively, press a room button on the AES or AAE (if connected).

### Control a Room

After a room is selected, a source can be selected, the room can be turned “off”, room and global volume can be adjusted, or the room output can be muted.

- Select a source by pressing the soft button labeled **Source** and turning the selection knob until the desired source is displayed on the LCD. Press the **ENTER** button to select the source. Press the soft button labeled **Control** (if available) to control the source. Press the **MORE** button to view options for adjusting audio parameters (bass, treble, balance, and loudness).
- Turn on the room by pressing the soft button labeled **On**.
- Turn off the room by pressing the soft button labeled **Off**.
- Adjust the room’s volume by turning the volume knob. The volume level will be displayed on the LCD.
- Adjust the volume in all rooms that are on by pressing the soft button labeled **Global** and turning the volume knob. The global volume level will be displayed on the LCD. Press **MENU** to return to the room menu.

Adjusting the global volume adjusts the volume in every room that is currently turned on. The volumes are adjusted proportionately so the room volume levels do not jump to the same level when the global volume control is used.

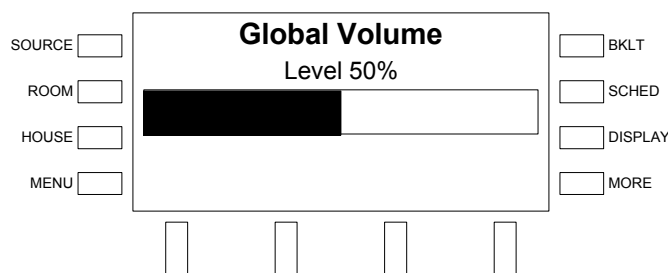
**Global Volume**

- Mute the room output by pressing the **MUTE** button (the MUTE LED will light). Unmute the room by pressing the **MUTE** button again.

**Adjust the Bass**

The bass level of each room can be adjusted independently.

- While in *Room* mode, press the **MORE** button.
- Press the soft button labeled **Bass** to open the Bass control.

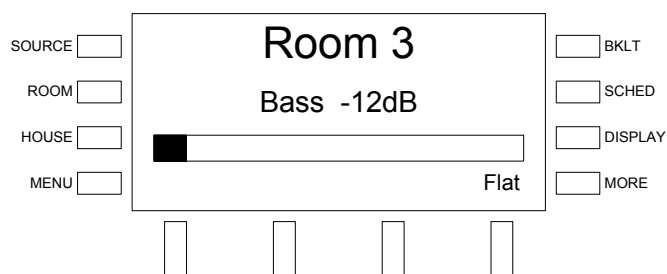
**Bass Control**

- Adjust the bass level with the selection knob. Turn clockwise to raise the bass level or counterclockwise to lower the bass level. Press the soft button labeled **Flat** to set the bass level to 0dB.

---

**NOTE:** Other rooms can be adjusted by pressing a different room button.

---

- Press **MENU** to save changes and return to the previous screen.

**Adjust the Treble**

The treble levels of each room can be adjusted independently.

- While in *Room* mode, press the **MORE** button.
- Press the soft button labeled **Treble** to open the Treble control.

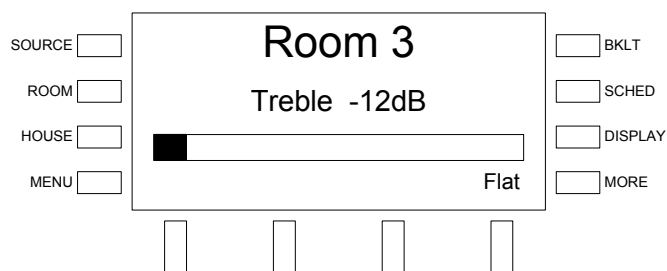
**Treble Control**



- Adjust the treble level with the selection knob. Turn clockwise to raise the treble level or counterclockwise to lower the treble level. Press the soft button labeled **Flat** to set the treble level to 0dB.

---

**NOTE:** Other rooms can be adjusted by pressing a different room button.

---

- Press the **MENU** button to save changes and return to the previous screen.

**Adjust the Balance**

The balance of each room can be adjusted independently.

- While in *Room* mode, press the **MORE** button.
- Press the soft button labeled **Balance** to open the Balance control.

**Balance Control**

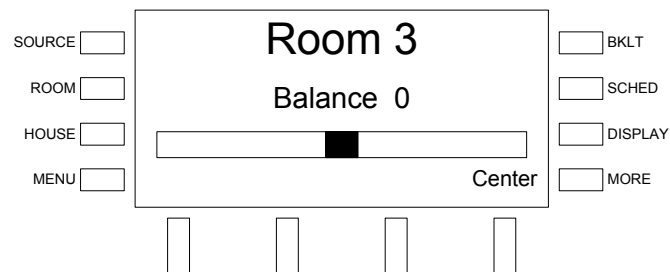

- Adjust the balance with the selection knob. Turn clockwise to set the balance to the right or counterclockwise to set the balance to the left. Press the soft button labeled **Center** to center the balance.

---

**NOTE:** Other rooms can be adjusted by pressing a different room button.

---

- Press **MENU** to save changes and return to the previous screen.

**Set Loudness**

The loudness settings of each room can be adjusted independently.

- While in *Room* mode, press the **MORE** button.
- Press the soft button labeled **Loud** to open the Loudness control.

**Loudness Control**

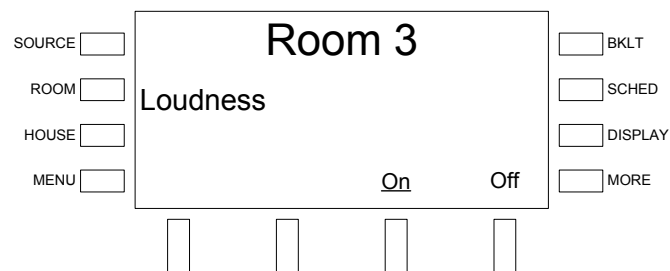

- The current setting is underlined. To turn loudness on, press the soft button labeled **On**. To turn loudness off, press the soft button labeled **Off**.

---

**NOTE:** Other rooms can be adjusted by pressing a different room button.

---

- Press **MENU** to save changes and return to the previous screen.

## Recall a Preset Group

Press any preset group button to recall a preset group. If a room is shared by two or more preset groups, the source from the most recently selected preset group will be routed to all of the selected groups.

## Lock and Unlocking the Front Panel Controls

The front panel controls can be locked by pressing the **MENU** and **DISPLAY** buttons simultaneously for five seconds.

The front panel controls can be unlocked by pressing the **MENU** and **DISPLAY** buttons simultaneously for five seconds.

## Turn off the System

Press **STANDBY** to turn off all of the rooms.

---

## Programming Software

Refer to this section only if a custom program for the AES is to be created.

A built-in program containing the out-of-the-box functionality resides in a protected area of the AES' flash memory. The program cannot be erased and can be recalled at any time by holding the software reset button during a hardware reset.

The built-in-program cannot be modified using the tools described in this section.

---

### Have a question or comment about Crestron software?

Answers to frequently asked questions (FAQs) can be viewed in the Online Help section of the Crestron website. To post a question or view questions you have submitted to Crestron's True Blue Support, log in at <http://support.crestron.com>. First-time users will need to establish a user account.

---

### Earliest Version Software Requirements for the PC

**NOTE:** Crestron recommends that you use the latest software to take advantage of the most recently released features. The latest software is available from the Crestron website.

**NOTE:** Crestron software and any files on the website are for authorized Crestron dealers and Crestron Authorized Independent Programmers (CAIP) only. New users may be required to register to obtain access to certain areas of the site (including the FTP site).

---

Crestron has developed an assortment of Windows®-based software tools to develop a Cresnet system. The following are the minimum recommended software versions for the PC:

#### *Software*

TASK	REQUIRED SOFTWARE VERSION
Simplified programming with wizards for Adagio systems (optional but recommended)	Adagio Composer; part of Crestron SystemBuilder™ version 3.0 (3.1.18 if using ATC-AMFMSR or AES-SR) or later with SystemBuilder Templates version 3.0 (3.2 if using ATC-AMFMSR or AES-SR) or later; Refer to software release notes or Crestron website for other required Crestron software packages
Program the AES functions	SIMPL Windows version 2.07.20 or later with SIMPL+ Cross Compiler version 1.1 or later; Also requires Crestron Database version 18.0 or later (18.6 if using ATC-AMFMSR or AES-SR)
Uploading program and firmware	Crestron Toolbox 1.02.17 or later

*(Continued on following page)*

*Software (Continued)*

TASK	REQUIRED SOFTWARE VERSION
Create custom LCD screens and page flips for custom programs	Vision Tools® Pro-e version 3.5 or later (add AES Front Panel Patch 1.0 if using ATC-AMFMSR or AES-SR); Requires Crestron Database version 18.0 or later (18.6 if using ATC-AMFMSR or AES-SR)
Create labels for room and preset group buttons	Crestron Engraver 2.7.0.1 or later; Requires Crestron Database version 18.0 or later

## Programming with Adagio Composer

To add additional Crestron sources, third-party sources, and interfaces use Adagio Composer. Adagio Composer is part of the Crestron SystemBuilder application which can be downloaded from the Crestron website.

Adagio Composer provides a quick method of configuring a custom audio distribution system without prior programming knowledge. For additional details, download Adagio Composer from the Crestron website and examine the extensive help file.

To create more advanced systems that include non-audio distribution devices such as lighting and HVAC, use Crestron SystemBuilder or SIMPL Windows.

## Programming with Crestron SystemBuilder

The easiest method of programming a Crestron system. For additional details, download SystemBuilder from the Crestron website and examine the extensive help file.

Any program created for the AES with SystemBuilder will include the out-of-the-box functionality in addition to any additional programming created with SystemBuilder.

For lower level control and additional programming flexibility, use SIMPL Windows.

## Programming with SIMPL Windows

---

**NOTE:** While SIMPL Windows can be used to program the AES, it is recommended to use Adagio Composer or SystemBuilder for configuring a system.

---

SIMPL Windows is Crestron's premier software for programming Crestron control systems. It is organized into two separate, but equally important "Managers".

Any SIMPL Windows program written for an AES will contain all of the AES' out-of-the-box functions in a protected area of the program. The parts of the program that contain the out-of-the-box functions are locked and cannot be changed or deleted. When a program is compiled, the custom program plus the out-of-the-box program's logic, default front panel operation, and control device (APAD or keypad) logic are loaded.

---

**NOTE:** When programming an AES in SIMPL Windows, always begin with the example program and modify as required. To find example programs, refer to "Example Program" on page 67. Also visit Crestron's True Blue Support on the web for more programming tips.

---

**Configuration Manager**

Configuration Manager is the view where programmers “build” a Crestron control system by selecting hardware from the *Device Library*.

- To incorporate the AES into the system, drag the AES from the Control Systems folder of the *Device Library* and drop it in the *System Views*.

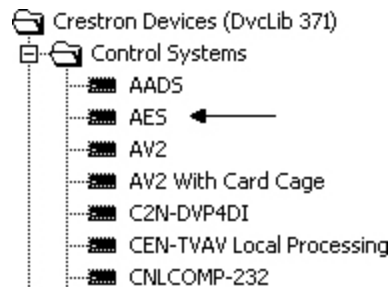
**Locating the AES in the Device Library****Programming Manager**

Programming Manager is the view where programmers "program" a Crestron control system by assigning signals to symbols.

Signals that are part of the AES’ out-of-the-box functionality are locked and cannot be modified or deleted. Locked signals are grayed out in the AES’ SIMPL Windows symbols. To prevent corruption of the out-of-the-box functionality, locked signals names should not be copied or driven to other destinations in the SIMPL Windows program.

---

**NOTE:** If using SIMPL Windows version 2.08.19 or later, signals that are part of the out-of-the-box functionality may be hidden from view. To view hidden signals in a program containing out-of-the-box functionality, select *Display Out Of The Box Functionality (OOTBF) Programming* in the “SIMPL Windows Preferences” window (**Options | Preferences...**).

---

The symbol can be viewed by double clicking on the icon or dragging it into *Detail View*. A description for each signal in the symbol is described in the SIMPL Windows help file (**F1**).

## Programming with VisionTools Pro-e

LCD screens and page flips can be created in VisionTools Pro-e (VT Pro-e) for custom programs using the **HOUSE** button on the AES front panel. For more information, refer to the VT Pro-e help file (**F1**).

## Switching Programs

If a custom program is loaded into the AES, the AES will run the custom program when it boots up. To switch to the out-of-the-box program:

1. Press and release **HW-R**.
2. Press and hold **SW-R** until "Bypassing Custom Program, Running OOTBF" is displayed on the LCD.
3. To return to the custom program simply press **HW-R** or cycle power.

## Saving Settings

Settings such as tone/volume levels (out-of-the-box and custom programs) and input/output names (out-of-the-box programs) are stored in an xml and text file that can be recalled should a AES program need to be updated.

To save settings for later use, use the Crestron Toolbox File Manager utility to retrieve the \*.xml (where \* can be “ootbf” for settings made when running the out-of-the-box functionality program or “custom” for settings made when running a custom program) and *System Configuration.txt* files from the NVRAM Disk directory. After the new out-of-the-box functionality program or custom program has been loaded, use Windows Explorer and Crestron Toolbox' File Manager utility to place the appropriate \*.xml and *System Configuration.txt* files in the NVRAM Disk directory and reboot the processor. For instructions on using Crestron Toolbox' File Manager utility, refer to the Crestron Toolbox help file.

---

**NOTE:** If switching to a different type of program (i.e. from out-of-the-box functionality to custom or vice-versa), the retrieved xml file can be renamed (*ootbf.xml* becomes *custom.xml* and *custom.xml* becomes *ootbf.xml*). The running program will import any relevant settings. Verify that all of the required settings are correct.

---

## Example Program

An example program for the AES is available from the Crestron website (<http://www.crestron.com/exampleprograms>).

## Uploading and Upgrading

Crestron recommends using the latest programming software and that each device contains the latest firmware to take advantage of the most recently released features. However, before attempting to upload or upgrade it is necessary to establish communication. Once communication has been established, files (for example, programs, or firmware) can be transferred to the control system (and/or device). Finally, program checks can be performed (such as changing the device ID or creating an IP table) to ensure proper functioning.

While the next section provides an overview for communication, refer to “Establishing Communications with the Control System” in the Crestron 2-Series Control Systems Reference Guide (Doc. 6256) for connection details. If communications cannot be established, refer to “Troubleshooting Communications” in the same guide.

### Establishing Communication

Use Crestron Toolbox for communicating with the AES; refer to the Crestron Toolbox help file for details. There are three methods of communication.

#### Direct Serial Communication

**NOTE:** Serial Communication or USB communication (see below) must be used for initial setup of Ethernet parameters when the out-of-the-box functionality is not used.

#### Direct Serial Communication

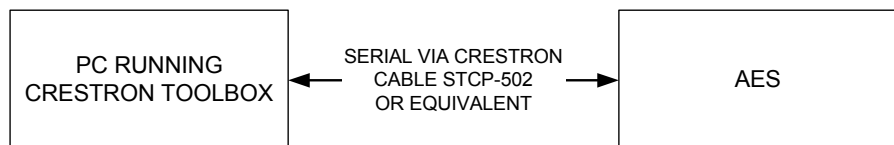



- The **COMPUTER** port on the AES connects to the serial port on the PC via the included serial cable (Crestron STCP-502PC or equivalent).
- Use the Address Book in Crestron Toolbox to create an entry using the expected serial communication protocol (RS232, auto-detect baud rate, no parity, 8 data bits, 1 stop bit, XON/XOFF disabled, RTS/CTS enabled).
- Display the AES’ “System Info” window (click the  icon); communications are confirmed when the device information is displayed.

#### USB Communication

**NOTE:** USB Communication or Serial communication (shown above) must be used for initial setup of Ethernet parameters when the out-of-the-box functionality is not used.

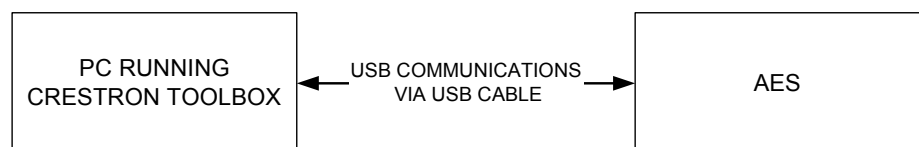
#### USB Communication



- The **USB** port on the AES connects to the USB port on the PC via the included USB cable.
- Use the Address Book in Crestron Toolbox to create an entry using the expected communication protocol (USB). When multiple USB devices are connected, identify the AES by entering “AES” in the *Model* textbox, the unit’s serial number in the *Serial* textbox or the unit’s hostname in the *Hostname* textbox. The hostname can be found in the “System Info” window in the section marked *Ethernet* however, communications must be established in order to see this information in the “System Info” window.
- Display the AES’ “System Info” window (click the  icon); communications are confirmed when the device information is displayed.

### TCP/IP Communication

**NOTE:** A connection to an Ethernet network is required for operation with a CEN-IDOC, AAS, or any other TCP/IP enabled device.

### Ethernet Communication

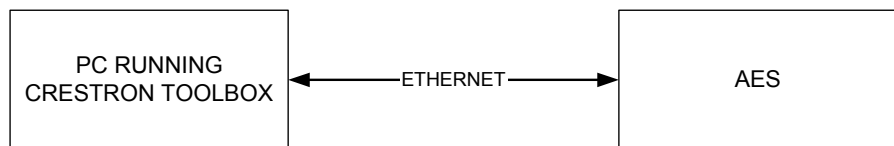

- Establish serial or USB communication between AES and PC.
- Enter the IP address, IP mask, and default router of the AES via Crestron Toolbox (**Functions | Ethernet Addressing**); otherwise enable DHCP.

**NOTE:** When taken out of the box, the AES is configured for DHCP operation. If a DHCP server is available and the AES is connected to the network, the IP address can be obtained from the *About* screen as described on page 32.

- Confirm Ethernet connections between AES and PC. If connecting through a hub, use CAT5 straight through cables with 8-pin RJ-45 connectors. Alternatively, Use a CAT5 crossover cable to connect the two **LAN** ports directly, without using a hub.
- Use the Address Book in Crestron Toolbox to create an entry for the AES with the AES’ TCP/IP communication parameters.
- Display the “System Info” window (click the  icon) and select the AES entry. Communications are confirmed when the device information is displayed.

## Programs and Firmware

Program or firmware files may be distributed from programmers to installers or from Crestron to dealers. Firmware upgrades are available from the Crestron website as new features are developed after product releases. One has the option to upload programs via the programming software or to upload and upgrade via the Crestron Toolbox. For details on uploading and upgrading, refer to the SIMPL Windows help file or the Crestron Toolbox help file.



**SIMPL Windows**

If a SIMPL Windows program is provided, it can be uploaded to the control system using SIMPL Windows or Crestron Toolbox.

**Firmware**

Check the Crestron website to find the latest firmware. (New users may be required to register to obtain access to certain areas of the site, including the FTP site.)

Upgrade AES firmware via Crestron Toolbox.

- Establish serial, USB, or TCP/IP communications with the AES and display the “System Info” window.
- Select **Functions | Firmware...** to upgrade the AES firmware.

For details on uploading and upgrading, refer to the SIMPL Windows help file or the Crestron Toolbox help file.

## Problem Solving

### Troubleshooting

The following table provides corrective action for possible trouble situations. If further assistance is required, please contact a Crestron customer service representative.

#### *AES Troubleshooting*

TROUBLE	POSSIBLE CAUSE(S)	CORRECTIVE ACTION
AES does not function.	AES is not receiving power.	Use the provided power cord. Verify connection.
C2N-DBF12 or APAD does not function.	AES is not communicating with C2N-DBF12 or APAD devices.	Verify that C2N-DBF12 and APAD devices are properly connected to the AES and are identified by the AES as described on page 29.
AES only allows six rooms (maximum) when using the out-of-the-box functionality.	AAE is not properly connected to the AES.	Verify that the AAE is properly connected to the AES.
	AAE is not registered with AES.	Open Installer Tools and select "Identify Keypads". Identify all keypads in the system.
		Use Crestron Toolbox to manually set the AAEs Net ID to 31.
Buttons on AAE do not light or do anything.	AAE is not properly connected to the AES.	Verify that the AAE is properly connected to the AES.
	AAE is not registered with AES.	Open Installer Tools and select "Identify Keypads". Identify all keypads in the system.
		Use Crestron Toolbox to manually set AAE Net ID to 31.
Tuner cards are not listed on the LCD or APAD as available sources.	Tuner card is not properly installed.	Refer to the tuner card's guide for installation instructions.
CEN-IDOC or AAS devices not listed on the LCD or APAD as available sources.	CEN-IDOC or AAS are not receiving power.	Verify that each device is receiving power.
	CEN-IDOC or AAS are not communicating with AES over Ethernet.	Verify each device's TCP/IP settings.

*(Continued on following page)*

*AES Troubleshooting (Continued)*

TROUBLE	POSSIBLE CAUSE(S)	CORRECTIVE ACTION
Sound is not heard.	Room is muted or turned off.	Turn off mute function or route a source to the room.
	Volume is turned down.	Raise volume to an audible level.
	Speakers are not properly connected.	Verify speaker connections.
	Source is not selected/properly connected.	Verify that source is selected and properly connected.

### Check Network Wiring

**Use the Right Wire**

In order to ensure optimum performance over the full range of your installation topology, Crestron Certified Wire, and only Crestron Certified Wire, may be used. Failure to do so may incur additional charges if support is required to identify performance deficiencies because of using improper wire.

**Calculate Power**

**CAUTION:** Use only Crestron power supplies for Crestron equipment. Failure to do so could cause equipment damage or void the Crestron warranty.

**CAUTION:** Provide sufficient power to the system. Insufficient power can lead to unpredictable results or damage to the equipment. Please use the Crestron Power Calculator to help calculate how much power is needed for the system (<http://www.crestron.com/calculators>).

When calculating the length of wire for a particular Cresnet run, the wire gauge and the Cresnet power usage of each network unit to be connected must be taken into consideration. Use Crestron Certified Wire only. If Cresnet units are to be daisy-chained on the run, the Cresnet power usage of each network unit to be daisy-chained must be added together to determine the Cresnet power usage of the entire chain. If the unit is home-run from a Crestron system power supply network port, the Cresnet power usage of that unit is the Cresnet power usage of the entire run. The wire gauge and the Cresnet power usage of the run should be used in the following equation to calculate the cable length value on the equation's left side.

**Cable Length Equation**

$$L < \frac{40,000}{R \times P}$$

Where: L = Length of run (or chain) in feet  
 R = 6 Ohms (Crestron Certified Wire: 18 AWG (0.75 MM<sup>2</sup>))  
 or 1.6 Ohms (Cresnet HP: 12 AWG (4 MM<sup>2</sup>))  
 P = Cresnet power usage of entire run (or chain)

Make sure the cable length value is less than the value calculated on the right side of the equation. For example, a Cresnet run using 18 AWG Crestron Certified Wire and drawing 20 watts should not have a length of run more than 333 feet. If Cresnet HP is used for the same run, its length could extend to 1250 feet.

**NOTE:** All Crestron certified Cresnet wiring must consist of two twisted pairs. One twisted pair is the +24V conductor and the GND conductor and the other twisted pair is the Y conductor and the Z conductor.

**Strip and Tin Wire**

When daisy-chaining Cresnet units, strip the ends of the wires carefully to avoid nicking the conductors. Twist together the ends of the wires that share a pin on the network connector, and tin the twisted connection. Apply solder only to the ends of the twisted wires. Avoid tinning too far up the wires or the end becomes brittle. Insert

the tinned connection into the Cresnet connector and tighten the retaining screw. Repeat the procedure for the other three conductors.

#### Add Hubs

For larger networks (i.e., greater than 28 network devices), it may become necessary to add a Cresnet Hub/Repeater (CNXHUB) to maintain signal quality throughout the network. Also, for networks with lengthy cable runs, it may be necessary to add a Hub/Repeater after only 20 devices.

## Reference Documents

The latest version of all documents mentioned within the guide can be obtained from the Crestron website (<http://www.crestron.com/manuals>). This link will provide a list of product manuals arranged in alphabetical order by model number.

#### List of Related Reference Documents

DOCUMENT TITLE
2-Series Control Systems Reference Guide
AAE Audio Expander
AAS Audio Server
APAD Wall Mount LCD Controller
ATC-AMFM2 Dual AM/FM Tuner Card
ATC-AMFMXM AM/FM/XM Tuner Card
ATC-AMFMSR AM/FM/SIRIUS Tuner Card
C2N-DBF12 Decorator Wall Panels
CEN-IDOC Interface for Apple iPod®
Crestron e-Control Reference Guide
User Interface Device Out-Of-The-Box Functionality Guide

## Further Inquiries

If you cannot locate specific information or have questions after reviewing this guide, please take advantage of Crestron's award winning customer service team by calling the Crestron corporate headquarters at 1-888-CRESTRON [1-888-273-7876]. For assistance in your local time zone, refer to the Crestron website (<http://www.crestron.com/>) for a listing of Crestron worldwide offices.

You can also log onto the online help section of the Crestron website to ask questions about Crestron products. First-time users will need to establish a user account to fully benefit from all available features.

## Future Updates

As Crestron improves functions, adds new features, and extends the capabilities of the AES, additional information may be made available as manual updates. These updates are solely electronic and serve as intermediary supplements prior to the release of a complete technical documentation revision.

Check the Crestron website periodically for manual update availability and its relevance. Updates are identified as an “Addendum” in the Download column.

---

## Software License Agreement

This License Agreement (“Agreement”) is a legal contract between you (either an individual or a single business entity) and Crestron Electronics, Inc. (“Crestron”) for software referenced in this guide, which includes computer software and as applicable, associated media, printed materials and “online” or electronic documentation (the “Software”).

BY INSTALLING, COPYING OR OTHERWISE USING THE SOFTWARE, YOU REPRESENT THAT YOU ARE AN AUTHORIZED DEALER OF CRESTRON PRODUCTS OR A CRESTRON AUTHORIZED INDEPENDENT PROGRAMMER AND YOU AGREE TO BE BOUND BY THE TERMS OF THIS AGREEMENT. IF YOU DO NOT AGREE TO THE TERMS OF THIS AGREEMENT, DO NOT INSTALL OR USE THE SOFTWARE.

IF YOU HAVE PAID A FEE FOR THIS LICENSE AND DO NOT ACCEPT THE TERMS OF THIS AGREEMENT, CRESTRON WILL REFUND THE FEE TO YOU PROVIDED YOU (1) CLICK THE DO NOT ACCEPT BUTTON, (2) DO NOT INSTALL THE SOFTWARE AND (3) RETURN ALL SOFTWARE, MEDIA AND OTHER DOCUMENTATION AND MATERIALS PROVIDED WITH THE SOFTWARE TO CRESTRON AT: CRESTRON ELECTRONICS, INC., 15 VOLVO DRIVE, ROCKLEIGH, NEW JERSEY 07647, WITHIN 30 DAYS OF PAYMENT.

### LICENSE TERMS

Crestron hereby grants You and You accept a nonexclusive, nontransferable license to use the Software (a) in machine readable object code together with the related explanatory written materials provided by Crestron (b) on a central processing unit (“CPU”) owned or leased or otherwise controlled exclusively by You and (c) only as authorized in this Agreement and the related explanatory files and written materials provided by Crestron.

If this software requires payment for a license, you may make one backup copy of the Software, provided Your backup copy is not installed or used on any CPU. You may not transfer the rights of this Agreement to a backup copy unless the installed copy of the Software is destroyed or otherwise inoperable and You transfer all rights in the Software.

You may not transfer the license granted pursuant to this Agreement or assign this Agreement without the express written consent of Crestron.

If this software requires payment for a license, the total number of CPU’s on which all versions of the Software are installed may not exceed one per license fee (1) and no concurrent, server or network use of the Software (including any permitted back-up copies) is permitted, including but not limited to using the Software (a) either directly or through commands, data or instructions from or to another computer (b) for local, campus or wide area network, internet or web hosting services or (c) pursuant to any rental, sharing or “service bureau” arrangement.

The Software is designed as a software development and customization tool. As such Crestron cannot and does not guarantee any results of use of the Software or that the Software will operate error free and You acknowledge that any development that You perform using the Software or Host Application is done entirely at Your own risk.

The Software is licensed and not sold. Crestron retains ownership of the Software and all copies of the Software and reserves all rights not expressly granted in writing.

### OTHER LIMITATIONS

You must be an Authorized Dealer of Crestron products or a Crestron Authorized Independent Programmer to install or use the Software. If Your status as a Crestron Authorized Dealer or Crestron Authorized Independent Programmer is terminated, Your license is also terminated.

You may not rent, lease, lend, sublicense, distribute or otherwise transfer or assign any interest in or to the Software.

You may not reverse engineer, decompile or disassemble the Software.

You agree that the Software will not be shipped, transferred or exported into any country or used in any manner prohibited by the United States Export Administration Act or any other export laws, restrictions or regulations (“Export Laws”). By downloading or installing the Software You (a) are certifying that You are not a national of Cuba, Iran, Iraq, Libya, North Korea, Sudan, Syria or any country to which the United States embargoes goods (b) are certifying that You are not otherwise prohibited from receiving the Software and (c) You agree to comply with the Export Laws.

If any part of this Agreement is found void and unenforceable, it will not affect the validity of the balance of the Agreement, which shall remain valid and enforceable according to its terms. This Agreement may only be modified by a writing signed by an authorized officer of Crestron. Updates may be licensed to You by Crestron with additional or different terms. This is the entire agreement between Crestron and You relating to the Software and it supersedes any prior representations, discussions, undertakings, communications or advertising relating to the Software. The failure of either party to enforce any right or take any action in the event of a breach hereunder shall constitute a waiver unless expressly acknowledged and set forth in writing by the party alleged to have provided such waiver.

If You are a business or organization, You agree that upon request from Crestron or its authorized agent, You will within thirty (30) days fully document and certify that use of any and all Software at the time of the request is in conformity with Your valid licenses from Crestron or its authorized agent.

Without prejudice to any other rights, Crestron may terminate this Agreement immediately upon notice if you fail to comply with the terms and conditions of this Agreement. In such event, you must destroy all copies of the Software and all of its component parts.

#### PROPRIETARY RIGHTS

**Copyright.** All title and copyrights in and to the Software (including, without limitation, any images, photographs, animations, video, audio, music, text and “applets” incorporated into the Software), the accompanying media and printed materials and any copies of the Software are owned by Crestron or its suppliers. The Software is protected by copyright laws and international treaty provisions. Therefore, you must treat the Software like any other copyrighted material, subject to the provisions of this Agreement.

**Submissions.** Should you decide to transmit to Crestron’s website by any means or by any media any materials or other information (including, without limitation, ideas, concepts or techniques for new or improved services and products), whether as information, feedback, data, questions, comments, suggestions or the like, you agree such submissions are unrestricted and shall be deemed non-confidential and you automatically grant Crestron and its assigns a non-exclusive, royalty-free, worldwide, perpetual, irrevocable license, with the right to sublicense, to use, copy, transmit, distribute, create derivative works of, display and perform the same.

**Trademarks.** CRESTRON and the Swirl Logo are registered trademarks of Crestron Electronics, Inc. You shall not remove or conceal any trademark or proprietary notice of Crestron from the Software including any back-up copy.

#### GOVERNING LAW

This Agreement shall be governed by the laws of the State of New Jersey, without regard to conflicts of laws principles. Any disputes between the parties to the Agreement shall be brought in the state courts in Bergen County, New Jersey or the federal courts located in the District of New Jersey. The United Nations Convention on Contracts for the International Sale of Goods shall not apply to this Agreement.

#### CRESTRON LIMITED WARRANTY

CRESTRON warrants that: (a) the Software will perform substantially in accordance with the published specifications for a period of ninety (90) days from the date of receipt and (b) that any hardware accompanying the Software will be subject to its own limited warranty as stated in its accompanying written material. Crestron shall, at its option, repair or replace or refund the license fee for any Software found defective by Crestron if notified by you within the warranty period. The foregoing remedy shall be your exclusive remedy for any claim or loss arising from the Software.

CRESTRON shall not be liable to honor warranty terms if the product has been used in any application other than that for which it was intended or if it as been subjected to misuse, accidental damage, modification or improper installation procedures. Furthermore, this warranty does not cover any product that has had the serial number or license code altered, defaced, improperly obtained or removed.

Notwithstanding any agreement to maintain or correct errors or defects, Crestron shall have no obligation to service or correct any error or defect that is not reproducible by Crestron or is deemed in Crestron’s reasonable discretion to have resulted from (1) accident; unusual stress; neglect; misuse; failure of electric power, operation of the Software with other media not meeting or not maintained in accordance with the manufacturer’s specifications or causes other than ordinary use; (2) improper installation by anyone other than Crestron or its authorized agents of the Software that deviates from any operating procedures established by Crestron in the material and files provided to You by Crestron or its authorized agent; (3) use of the Software on unauthorized hardware or (4) modification of, alteration of or additions to the Software undertaken by persons other than Crestron or Crestron’s authorized agents.

ANY LIABILITY OF CRESTRON FOR A DEFECTIVE COPY OF THE SOFTWARE WILL BE LIMITED EXCLUSIVELY TO REPAIR OR REPLACEMENT OF YOUR COPY OF THE SOFTWARE WITH ANOTHER COPY OR REFUND OF THE INITIAL LICENSE FEE CRESTRON RECEIVED FROM YOU FOR THE DEFECTIVE COPY OF THE PRODUCT. THIS WARRANTY SHALL BE THE SOLE AND EXCLUSIVE REMEDY TO YOU. IN NO EVENT SHALL CRESTRON BE LIABLE FOR INCIDENTAL, CONSEQUENTIAL, SPECIAL OR PUNITIVE DAMAGES OF ANY KIND (PROPERTY OR ECONOMIC DAMAGES INCLUSIVE), EVEN IF A CRESTRON REPRESENTATIVE HAS BEEN ADVISED OF THE POSSIBILITY OF SUCH DAMAGES OR OF ANY CLAIM BY ANY THIRD PARTY. CRESTRON MAKES NO WARRANTIES, EXPRESS OR IMPLIED, AS TO TITLE OR INFRINGEMENT OF THIRD-PARTY RIGHTS, MERCHANTABILITY OR FITNESS FOR ANY PARTICULAR PURPOSE, OR ANY OTHER WARRANTIES, NOR AUTHORIZES ANY OTHER PARTY TO OFFER ANY WARRANTIES, INCLUDING WARRANTIES OF MERCHANTABILITY FOR THIS PRODUCT. THIS WARRANTY STATEMENT SUPERSEDES ALL PREVIOUS WARRANTIES.

---

## Return and Warranty Policies

### Merchandise Returns / Repair Service

1. No merchandise may be returned for credit, exchange, or service without prior authorization from CRESTRON. To obtain warranty service for CRESTRON products, contact an authorized CRESTRON dealer. Only authorized CRESTRON dealers may contact the factory and request an RMA (Return Merchandise Authorization) number. Enclose a note specifying the nature of the problem, name and phone number of contact person, RMA number, and return address.
2. Products may be returned for credit, exchange, or service with a CRESTRON Return Merchandise Authorization (RMA) number. Authorized returns must be shipped freight prepaid to CRESTRON, 6 Volvo Drive, Rockleigh, N.J. or its authorized subsidiaries, with RMA number clearly marked on the outside of all cartons. Shipments arriving freight collect or without an RMA number shall be subject to refusal. CRESTRON reserves the right in its sole and absolute discretion to charge a 15% restocking fee, plus shipping costs, on any products returned with an RMA.
3. Return freight charges following repair of items under warranty shall be paid by CRESTRON, shipping by standard ground carrier. In the event repairs are found to be non-warranty, return freight costs shall be paid by the purchaser.

### CRESTRON Limited Warranty

CRESTRON ELECTRONICS, Inc. warrants its products to be free from manufacturing defects in materials and workmanship under normal use for a period of three (3) years from the date of purchase from CRESTRON, with the following exceptions: disk drives and any other moving or rotating mechanical parts, pan/tilt heads and power supplies are covered for a period of one (1) year; touchscreen display and overlay components are covered for 90 days; batteries and incandescent lamps are not covered.

This warranty extends to products purchased directly from CRESTRON or an authorized CRESTRON dealer. Purchasers should inquire of the dealer regarding the nature and extent of the dealer's warranty, if any.

CRESTRON shall not be liable to honor the terms of this warranty if the product has been used in any application other than that for which it was intended, or if it has been subjected to misuse, accidental damage, modification, or improper installation procedures. Furthermore, this warranty does not cover any product that has had the serial number altered, defaced, or removed.

This warranty shall be the sole and exclusive remedy to the original purchaser. In no event shall CRESTRON be liable for incidental or consequential damages of any kind (property or economic damages inclusive) arising from the sale or use of this equipment. CRESTRON is not liable for any claim made by a third party or made by the purchaser for a third party.

CRESTRON shall, at its option, repair or replace any product found defective, without charge for parts or labor. Repaired or replaced equipment and parts supplied under this warranty shall be covered only by the unexpired portion of the warranty.

Except as expressly set forth in this warranty, CRESTRON makes no other warranties, expressed or implied, nor authorizes any other party to offer any warranty, including any implied warranties of merchantability or fitness for a particular purpose. Any implied warranties that may be imposed by law are limited to the terms of this limited warranty. This warranty statement supersedes all previous warranties.

#### Trademark Information

All brand names, product names, and trademarks are the sole property of their respective owners. Windows is a registered trademark of Microsoft Corporation. Windows95/98/Me/XP and WindowsNT/2000 are trademarks of Microsoft Corporation. The XM name and XM Ready are registered trademarks of XM Satellite Radio Inc. "SIRIUS" and the SIRIUS dog logo are registered trademarks of SIRIUS Satellite Radio Inc. iPod is a trademark of Apple Computer, Inc., registered in the U.S. and other countries.



**Crestron Electronics, Inc.**  
15 Volvo Drive Rockleigh, NJ 07647  
Tel: 888.CRESTRON  
Fax: 201.767.7576  
[www.crestron.com](http://www.crestron.com)

**Operations Guide – DOC. 6456B**  
**(2014564)**  
**02.07**  
Specifications subject to  
change without notice.